SAFETY RELAY NL1/3-D



User's manual

CARLO GAVAZZI

SAIET Elettronica S.p.A. - A Member of CARLO GAVAZZI Group
via Serenari, 1 - 40013 Castel Maggiore (BO), Italy
Tel. +39 051 4178811 - Fax +39 051 4178800
<http://www.saiet.it/elettronica> E-mail: sales.el@saiet.it



Index

1. INTRODUCTION.....	3
2. SAFETY INDICATIONS.....	3
3. ASSEMBLY AND FUNCTION.....	4
3.1 <i>Power supply terminals</i>	4
3.2 <i>Input terminals</i>	4
3.3 <i>START terminals</i>	5
3.4 <i>Function</i>	5
4. MOUNTING AND OPENING	6
5. ELECTRONIC CONNECTION.....	6
5.1 <i>Close the feedback control loop and the activation circuit.</i> ..6	
5.2 <i>Close input circuit</i>	7
5.3 <i>Supply voltage</i>	7
6. MAINTENANCE AND REPAIR	7
7. FAULT DIAGNOSIS.....	8
8. APPLICATION EXAMPLES	8
9. WIRING HINTS FOR OUTPUT TERMINALS	9
10. TECHNICAL DATA	9

1. INTRODUCTION

This operating instruction is referred to the safety light curtains and light barriers control relay **NL1/3-D**.

This operating instruction is addressed to the following persons:

- Qualified professionals who plan and develop safety equipment for machines and plants and who are familiar with the safety instructions and safety regulations.
- Qualified professionals, who install safety equipment into machines and plants and put them into operation.

The operating instructions contains several symbols which are used to highlight important information.

WARNING

- ✓ This title is placed in front of text which has to be absolutely paid attention to. Nonobservance leads to serious injuries or damage to property.

IMPORTANT

- ✓ This title is placed in front of text which contains important information.

ACTIVITY

- ✓ This title is placed in front of activities.

RESULT

- ✓ After this title follows a description on how the situation has changed after an activity is performed.

2. SAFETY INDICATIONS

Application

The safety relay **NL1/3-D** can be used in applications together with:

- Electro Sensitive Protective Equipment (ESPE) type 4 (light curtains and light barriers).
- Electro Sensitive Protective Equipment (ESPE) type 2 (light curtains and light barriers) performing self-test.
- ✓ When using the **NL1/3-D** relay together with light barriers or light curtains, the monitoring of the START button is not single fault protected.

IMPORTANT

- ✓ Person and object protection are not guaranteed, if the safety relay is not used according to the defined application.

WARNING

FOR YOUR SAFETY!

Please, note the following points:

- ✓ The unit should only be installed and operated by persons who are familiar with both these instructions and the current regulations for safety at work and accident prevention. Electrical works may be

executed only by electrical specialist.

- ✓ Follow local regulations as regards preventative measures.
- ✓ The dangerous area must be observable by the mounting place of the START button.
- ✓ Starting the machine while standing in the dangerous area must be impossible. It is not allowed to reach the START button from the dangerous area.
- ✓ Any guarantee is void following opening of the housing or unauthorized modifications.
- ✓ Avoid mechanical vibrations greater than 5 g / 33 Hz when transporting and in operations.
- ✓ The unit should be panel

mounted in an enclosure rated at IP 54 or better, otherwise dampness or dust could lead to function impairment.

- ✓ Adequate fuse protection must be provided on all output safety contacts with capacitive and / or inductive loads.

3. ASSEMBLY AND FUNCTION

3.1 Power supply terminals

The supply voltage must be applied to the terminals A1 and A2. The **POWER** and **RESTART LOCK** LEDs illuminate. 24 VDC voltage is available at terminal S11.

3.2 Input terminals

The input terminals S12 and S22 have to be wired up to the ESPE

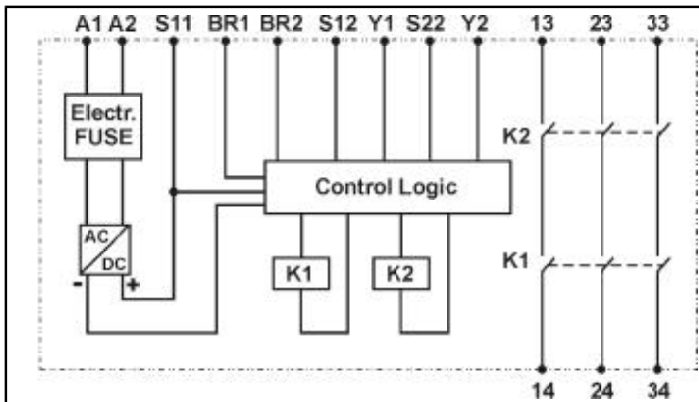

Fig. 1 - Functional circuit diagram of **NL1/3-D** relay

Terminal	Function / Connection
A1	+24VDC or AC supply
A2	GND or AC supply
S12	First input channel (PNP Channel 1)
S22	Second input channel (PNP Channel 2)
Y1-Y2	START (automatic or manual START)
BR1-BR2	START (only for automatic START)
13-14	First safety output (N.O.)
23-24	Second safety output (N.O.)
33-34	Third safety output (N.O.)

Table 1: Connections

outputs as shown in the application examples of this user's manual.

3.3 START terminals

To start the unit with manual START, terminals Y1 and Y2 must be bridged with a normally open contact, while terminals BR1 and BR2 must not be connected.

To start the unit with automatic

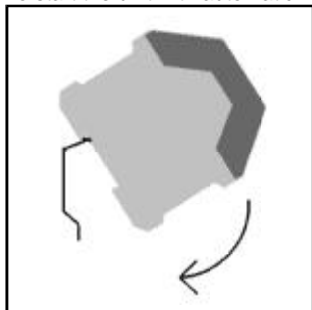

Fig. 2 - DIN-Rail mounting

START, terminals Y1 and Y2 must be short-circuited and terminals BR1 and BR2 must be short-circuited.

In series to the START button (Y1-Y2) an external contactor can be monitored.

3.4 Function

The unit is enabled to start when the light barrier or light curtain beams are not interrupted. At this time, the output contacts 13-14, 23-24, 33-34 close immediately (working with automatic START) or close after pressing the START button (working with manual START).

The LEDs **Channel 1** and **Channel 2** illuminate, while the LED **RESTART LOCK** turns off.

When the beams are interrupted, the output contacts 13-14, 23-24, 33-34 open immediately.

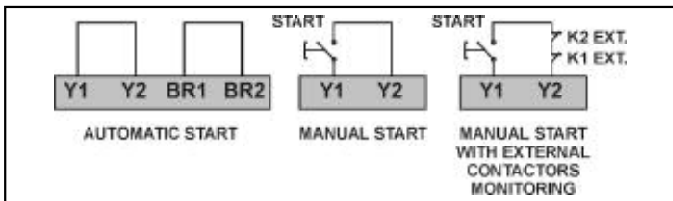

Fig. 3 - START Connections

The LEDs **Channel 1** and **Channel 2** turn off, while the LED **RESTART LOCK** turns on.

4. MOUNTING AND OPENING

The unit should be panel mounted in an enclosure rated at IP 54 or better, dust and humidity protected, because dampness or dust could lead to function impairment.

ACTIVITY

- ✓ There is a notch on the rear of the unit for DIN-Rail mounting.

Carry out the wire appropriate to the use of the unit, according to the application examples shown in this user's manual.

5. ELECTRONIC CONNECTION

5.1 Close the feedback control loop and the activation circuit.

ACTIVITY

✓ **Conditional activation (Manual START)**

Connect the START button (N.O.) to Y1-Y2 terminals

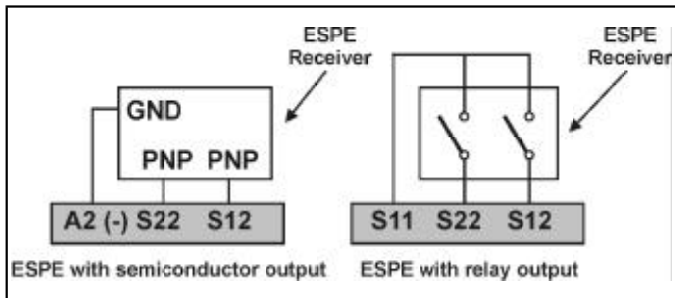

Fig. 4 - Relay or semiconductor input connection diagram

(without bridging the terminals BR1-BR2). N.C. Contacts of external contactors must be wired in series with the START button at the terminals Y1-Y2.

ACTIVITY

✓ Automatic activation

Bridge Y1-Y2 terminals.

Bridge BR1-BR2 terminals.

5.2 *Close input circuit*

ACTIVITY

✓ ESPE with relay outputs

Connect the first N.O. contact of the ESPE to the terminals S11-S22.

Connect the second N.O. contact of the ESPE to the terminals S11-S12.

ACTIVITY

✓ ESPE with semiconductor outputs

Connect PNP outputs from ESPE to the input terminals S12 and S22. The GND

terminal of the ESPE needs to be connected to the A2 terminal.

5.3 *Supply voltage*

ACTIVITY

- ✓ The supply voltage has to be connected directly to the terminals A1 and A2 of the safety relay.

WARNING

- ✓ *Please, note the maximum length of the cables!*
- ✓ *The terminal S11 is not intended for supplying other devices.*

6. MAINTENANCE AND REPAIR

The safety relay **NL1/3-D** is maintenance-free.

In event of failure, it is possible to change the defective device with a new one following the steps described below:

- ✓ Switch off the relay and remove the wirings from the device.
- ✓ Take off the defective device

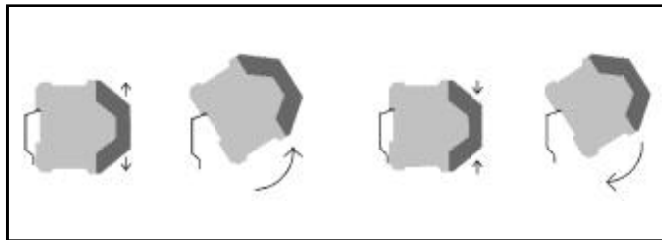

Fig. 5 - Change of the **NL1/3-D** safety relay

from the DIN-Rail.

- ✓ Mount the new device on the DIN-Rail.
- ✓ Insert and fix the cables on the new device.

7. FAULT DIAGNOSIS

Earth Fault (AC/DC version with electronic fuse protection).

An electronic fuse forces the output contacts to open. As soon as the fault cause is removed, and the rated power supply is applied, the device is ready for new operations.

Faulty contact condition

In the event of welded contacts, further activation is not possible following the opening of the input circuit.

Only one or no LED illuminates

External wiring or internal fault is present.

Check the external wiring and restart the safety relay.

If the fault is still present, contact SAJET Elettronica.

8. APPLICATION EXAMPLES

Example 1. Dual channel monitoring of light barrier or light curtains (ESPE with relay outputs).

Pressing the START button, the unit will be activated. The safety output contacts 13-14, 23-24, 33-34 close.

An interruption of the light beam of the light curtain/barrier resets immediately the safety relay: the safety output contacts 13-14, 23-24, 33-34 open.

Example 2. Dual channel monitoring of light barrier or light curtains (ESPE with semiconductor outputs and short circuit monitoring).

Pressing the START button, the unit will be activated. The safety output contacts 13-14, 23-24, 33-34 close.

An interruption of the light beam of the light curtain/barrier resets immediately the safety relay: the safety output contacts 13-14, 23-24, 33-34 open.

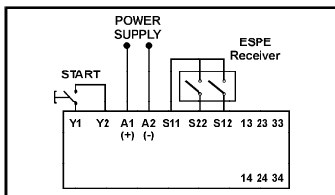

Fig. 6 - Example 1: Cat. Max: 3

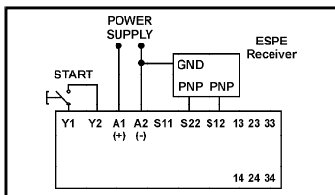

Fig. 7 - Example 2: Cat. Max: 4

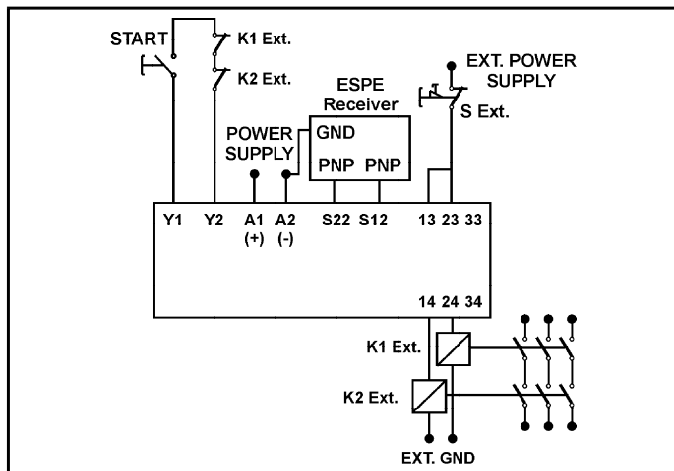

Fig. 8 - Example 3: Cat. Max: 4

Example 3. Dual channel monitoring of light barrier or light curtain with external contact extension.

For this application two external contactors with positive guidance must be used.

One N.C. contact of each external contactor must be connected in series to the START button to the terminals Y1-Y2 of the safety relay. Through the external switch SEXT, the external contactors can be operated or turned off at any time, also if the safety outputs are activated. To avoid cross connection, the external

contactors should be wired with separate coated cables.

9. WIRING HINTS FOR OUTPUT TERMINALS

The positive power supply voltage (for example L or 24 VDC, but not GND) should be routed via the output terminals. This will help to recognize shorts to GND or Earth.

Using R-C combination in parallel with inductive loads (for example coils of the external contactors) can reduce the wearing out of the output contacts.

10. TECHNICAL DATA

See the following tables.

ELECTRICAL DATA	VALUES
Power supply voltage (Uv)	24 VAC/DC (Elec.fuse protect)
Voltage range	0.9 ... 1.1 Uv
Frequency (AC Type)	50 - 60 Hz
Power Consumption (Approx.)	2.5 VA / 2.5 W
Starting Current at S12, S22	Max 390 mA
Permanent Current at S12, S22	20 mA
CONDUCTORS DATA	VALUES
Conductor connection	0.14 ÷ 2.5 mm ² Rigid Wire 0.14 ÷ 2.5 mm ² Flexible Wire
Max Conductor Length (input circuit, cross-section = 1.5 mm ²)	2x100 m
Maximum capacity of the input cables	150 nF/km
CONTACTS DATA	VALUES
Contact Function	3 N.O.
Contact type	Forced Guided Relays
Contact Material	AgSnO ₂ or comparable
Switching voltage	250 VAC , 24 VDC
Switching current	6A
Max switching capability (EN 60947-5-1)	AC 14 230V / 3A DC 13 24 V / 2,5A
Max switching capacity	1500 VA (ohms load)
Mechanical lifetime	10 ⁷ cycles
Electrical lifetime	10 ⁵ cycles
Creeping distance and clearance (DIN VDE 0160) (DIN VDE 0110)	Pollution degree: 2. Basis insulation: Overvoltage Category: 3 Protective Separation: Ov. Cat. 2
Contact security (DIN VDE 0660 - Part 200)	6 A fast or 4 A slow
Voltage at S11 terminal	24 VDC
Delay on de-energization	< 30 ms

<i>MECHANICAL DATA</i>	<i>VALUES</i>
Housing Material	Polyamid PA6.6
Dimensions (WxHxP)	22.5 x 114.5 x 99
Fastening	Click-fastening for DIN-rail
<i>ENVIRONMENTAL DATA</i>	<i>VALUES</i>
Operating Temperature	-25°C ... + 55°C
Max. Humidity	Altern.Cycle: 95% / 0-50 °C
Terminal type (DIN VDE 0470 Part 1)	IP 20
Housing type (DIN VDE 0470 Part 1)	IP 40
Shock resistance (DIN VDE 0160)	5g, 33 Hz



SAIET reserves the right to make improvements or changes without prior notice.