SAFETY RELAY NE1/4-D



User's manual

CARLO GAVAZZI

SAIET Elettronica S.p.A. - A Member of CARLO GAVAZZI Group
via Serenari, 1 - 40013 Castel Maggiore (BO), Italy
Tel. +39 051 4178811 - Fax +39 051 4178800
<http://www.saiet.it/elettronica> E-mail: sales.el@saiet.it



Index

1. INTRODUCTION.....	3
2. SAFETY INDICATIONS	3
3. ASSEMBLY AND FUNCTION.....	4
3.1 <i>Power supply terminals</i>	4
3.2 <i>Input terminals</i>	4
3.3 <i>START mode</i>	4
3.4 <i>Function</i>	4
4. MOUNTING AND OPENING	5
5. ELECTRONIC CONNECTION.....	6
5.1 <i>Close the feedback control loop and the activation circuit.</i> ..	6
5.2 <i>Close input circuit</i>	6
5.3 <i>Supply voltage</i>	7
6. MAINTENANCE AND REPAIR	7
7. FAULT DIAGNOSIS.....	7
8. APPLICATION EXAMPLES	8
9. WIRING HINTS FOR OUTPUT TERMINALS	8
10. TECHNICAL DATA	8

1. INTRODUCTION

This operating instruction is referred to the emergency stop and safety gate monitoring relay **NE1/4-D** (24 Vac/dc) and to the models supplied with an AC power supply and named **NE1/4-D/xxx** (where xxx is the AC supply voltage).

The **NE1/4-D** name, used in this manual, is referred to all the models (DC and AC supply), if not differently specified.

These instructions are addressed to the following persons:

- Qualified professionals who plan and develop safety equipment for machines and plants and who are familiar with the safety instructions and safety regulations.
- Qualified professionals, who install safety equipment into machines and plants and put them into operation.

This user's manual contains several symbols which are used to highlight important information.

WARNING

- ✓ This title is placed in front of text which has to be absolutely paid attention to. Nonobservance leads to serious injuries or damage to property.

IMPORTANT

- ✓ This title is placed in front of

text which contains important information.

ACTIVITY

- ✓ This title is placed in front of activities.

RESULT

- ✓ After this title follows a description on how the situation has changed after an activity is performed.

2. SAFETY INDICATIONS

Application

The safety relay **NE1/4-D** can be used for safety contact extension in safety-related parts of control systems.

IMPORTANT

- ✓ Person and object protection are not guaranteed, if the safety relay is not used according to the defined application.

WARNING

FOR YOUR SAFETY!

Please, note the following points:

- ✓ The unit should only be installed and operated by persons who are familiar with both these instructions and the current regulations for safety at work and accident prevention.
- ✓ Follow local regulations as regards preventative measures.
- ✓ Any guarantee is void following opening of the housing or unauthorized modifications.

- ✓ Avoid mechanical vibrations greater than 5 g / 33 Hz when transporting and in operations.
- ✓ The unit should be panel mounted in an enclosure rated at IP 54 or better, otherwise dampness or dust could lead to function impairment.
- ✓ Adequate fuse protection must be provided on all output safety contacts with capacitive and / or inductive loads.

3. ASSEMBLY AND FUNCTION

3.1 *Power supply terminals*

The supply voltage must be applied to the terminals A1 and A2. The **OUT OFF** LED illuminates.

3.2 *Input terminals*

The **NE1/4-D** is designed to

extend the number of the safety outputs of a master relay. Thus, the input terminals U1, K1, K21, U22 have to be wired up to the safety outputs of the master relay. It is possible to connect to the **NE1/4-D** relay one or two safety outputs of the master relay, depending on the application.

3.3 *START mode*

The **START** of the **NE1/4-D** relay is automatic: as soon as the safety outputs of the master relay close, the **NE1/4-D** relay closes its safety outputs.

3.4 *Function*

Starting from **NE1/4-D**, master relay and external contactors de-energized, when the input contacts (safety outputs of the master relay) close, the safety outputs 13-14, 23-24, 33-34, 43-44, 43-

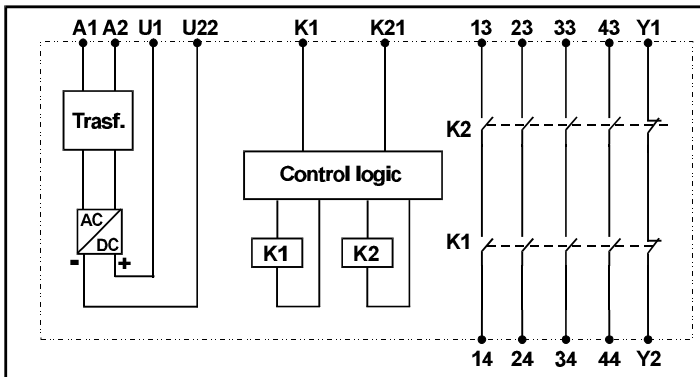

Fig. 1 - Functional circuit diagram of **NE1/4-D** relay

Terminal	Function / Connection
A1	+24VDC or AC supply
A2	GND or AC supply
U1-K1	First input channel (N.O. Safety contact from the master relay)
K21-U22	Second input channel (N.O. Safety contact from the master relay)
Y1-Y2	FEEDBACK output (to connect to the master relay)
13-14	First safety output (N.O.)
23-24	Second safety output (N.O.)
33-34	Third safety output (N.O.)
43-44	Fourth safety output (N.O.)

Table 1: Connections

44 close, while the feedback contact Y1-Y2 opens.

The **OUT OFF** LED switches OFF and the **Channel 1 & Channel 2** LEDs switch ON.

When one or both input contacts open, the safety outputs 13-14, 23-24, 33-34, 43-44 open, while the feedback contact Y1-Y2

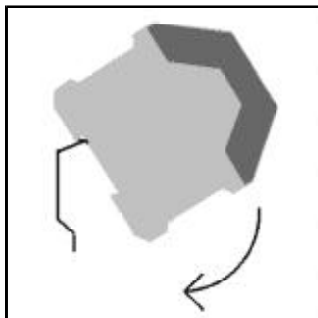

Fig. 2 - DIN-Rail mounting

closes.

The **OUT OFF** LED switches ON and the **Channel 1 & Channel 2** LEDs switch OFF.

RESULT

- ✓ If the **NE1/4-D** is configured for one-channel input, when the input contact opens, the power supply of the safety relay is switched off, so all LEDs are switched off.

4. MOUNTING AND OPENING

The unit should be panel mounted in an enclosure rated at IP 54 or better, otherwise dampness or dust could lead to function impairment.

ACTIVITY

- ✓ There is a notch on the rear of the unit for DIN-Rail mounting. Carry out the wire appropriate to

the use of the unit, according to the application examples shown in this user's manual.

5. ELECTRONIC CONNECTION

WARNING

- ✓ The safety relay **NE1/4-D** is designed for applications up to category 4 according to EN 954-1. The user must be informed that the safety category of the whole system is defined by the safety parts characterized by the lower safety category within the system.

5.1 Close the feedback control loop and the activation circuit.

ACTIVITY

✓ Connecting Y1-Y2

The terminals Y1-Y2 must be connected in series to the N.C.

contacts of the external contactors. This series must be connected to the master safety relay, so that it can check the integrity of the external contactors and of the **NE1/4-D** relay.

5.2 Close input circuit

ACTIVITY

✓ Single Channel

Connect the positive power supply to the first terminal of the safety output of the master relay and the second terminal to the A1 terminal of the **NE1/4-D** safety relay.

Connect a bridge between K1-U1 and between K21-U22.

ACTIVITY

✓ Dual channel

Connect the safety contacts from the master relay to U1-K1 and to K21-U22 input terminals.

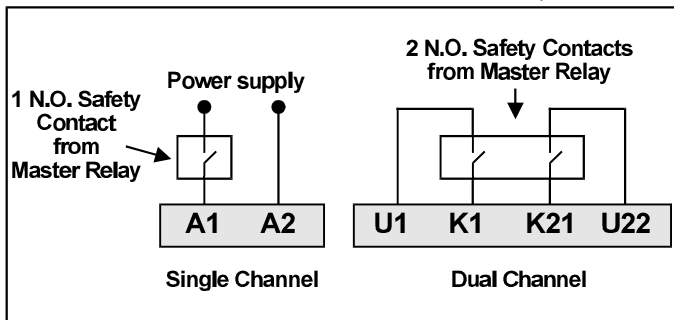

Fig. 3 - Single and dual Channel input connection diagram

5.3 Supply voltage

ACTIVITY

✓ Single Channel

The supply voltage (Uv(+)) / L has to be connected over the contact from the master safety relay to the terminals A1 of the relay.

The supply voltage Uv(-) / N has to be connected directly to the terminal A2 of the safety relay.

When using AC-supplied version, take care of the safety insulation.

ACTIVITY

✓ Dual Channel

The supply voltage has to be connected directly to the terminals A1 and A2 of the safety relay.

WARNING

- ✓ Please, note the maximum length of the cables!

6. MAINTENANCE AND REPAIR

The safety relay **NE1/4-D** is maintenance-free.

In event of failure, it is possible to change the defective device with a new one following the steps described below:

- Switch off the relay and remove the wiring from the device.
- Take off the defective device from the DIN-Rail.
- Mount the new device on the DIN-Rail.
- Insert and fix the wiring on the new device.

7. FAULT DIAGNOSIS

Earth Fault (AC/DC version with electronic fuse protection).

An electronic fuse forces the output contacts to open. As soon as the fault cause is removed, and the rated power supply is applied, the device is ready for new operations.

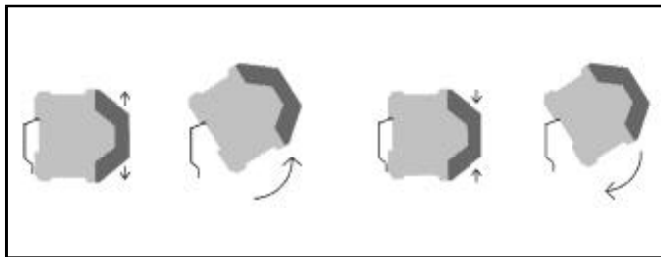

Fig. 4 - Change of the **NE1/4-D** safety relay

Faulty contact condition

In the event of welded contacts, further activation is not possible following the opening of the input circuit.

Only one or no LED illuminates

External wiring or internal fault is present.

Check the external wiring and restart the safety relay.

If the fault is still present, contact SAJET Elettronica.

8. APPLICATION EXAMPLES

Example 1. Dual channel contact extension (Fig. 3)

Closing the N.O. input contacts, the unit will be activated. The safety output contacts 13-14, 23-24, 33-34, 43-44 close and the feedback output contact Y1-Y2 opens.

Opening one or both N.O. input contacts resets immediately the safety relay: the safety output contacts 13-14, 23-24, 33-34, 43-44 open and the feedback output contact Y1-Y2 closes.

Example 2. Single channel contact extension (Fig. 3)

Closing the N.O. input contact, the unit will be activated (the input terminals K1-U1 and K21-U2 are bridged). The safety output contacts 13-14, 23-24, 33-34, 43-44 close and the feedback output contact Y1-Y2 opens.

Opening the N.O. input contact resets immediately the safety relay: the safety output contacts 13-14, 23-24, 33-34, 43-44 open and the feedback output contact Y1-Y2 closes.

9. WIRING HINTS FOR OUTPUT TERMINALS

The positive power supply voltage (for example L or 24 VDC, but not GND) should be routed via the output terminals. This will help to recognize shorts to GND or Earth.

Using R-C combination in parallel with inductive loads (for example coils of the external contactors) can reduce the wearing out of the output contacts.

10. TECHNICAL DATA

See the following tables.

ELECTRICAL DATA	VALUES
Power supply voltage (U _v)	24 VDC or AC supply
Voltage range	0.85 ... 1.1 U _v
Frequency (AC Type)	50 - 60 Hz
Power Consumption (Approx.)	Ca. 4 VA / 4 W
CONDUCTORS DATA	VALUES
Conductor connection	0.14 ÷ 2.5 mm ² Rigid Wire 0.14 ÷ 2.5 mm ² Flexible Wire
Max Conductor Length (input circuit, cross-section = 1.5 mm ²)	4x150 m
CONTACTS DATA	VALUES
Safety contact function	4 N.O.
Feedback output	1 N.C.
Contact type	Force Guided Relays
Contact Material	AgSnO ₂ or comparable
Switching voltage	250 VAC , 24 VDC
Switching current	6A
Max switching capacity	2000 VA (ohms load)
Mechanical lifetime	10 ⁷ cycles
Electrical lifetime	10 ⁵ cycles
Creeping distance and clearance (DIN VDE 0160)	<u>Pollution degree: 2.</u> <u>Overvoltage Category:</u> 3 / 250 V <u>Basis insulation: Overvoltage</u> <u>Category: 3 / 250 V</u>
Contact security (DIN VDE 0660 - Part 200)	6 A fast or 4 A slow
Delay on de-energization	< 30 ms

<i>MECHANICAL DATA</i>	<i>VALUES</i>
Housing Material	Polyamid PA6.6
Dimensions (WxHxP)	22.5 x 114.5 x 99
Fastening	Click-fastening for DIN-rail
<i>ENVIRONMENTAL DATA</i>	<i>VALUES</i>
Operating Temperature	-25°C + 55°C
Humidity	Altern.Cycle: 95% / 0-50 °C
Terminal type (DIN VDE 0470 Part 1)	IP 20
Housing type (DIN VDE 0470 Part 1)	IP 40
Shock resistance (DIN VDE 0160)	5g, 33 Hz



SAIET reserves the right to make improvements or changes without prior notice.