

SAFETY MODULE

M22A2/1-A

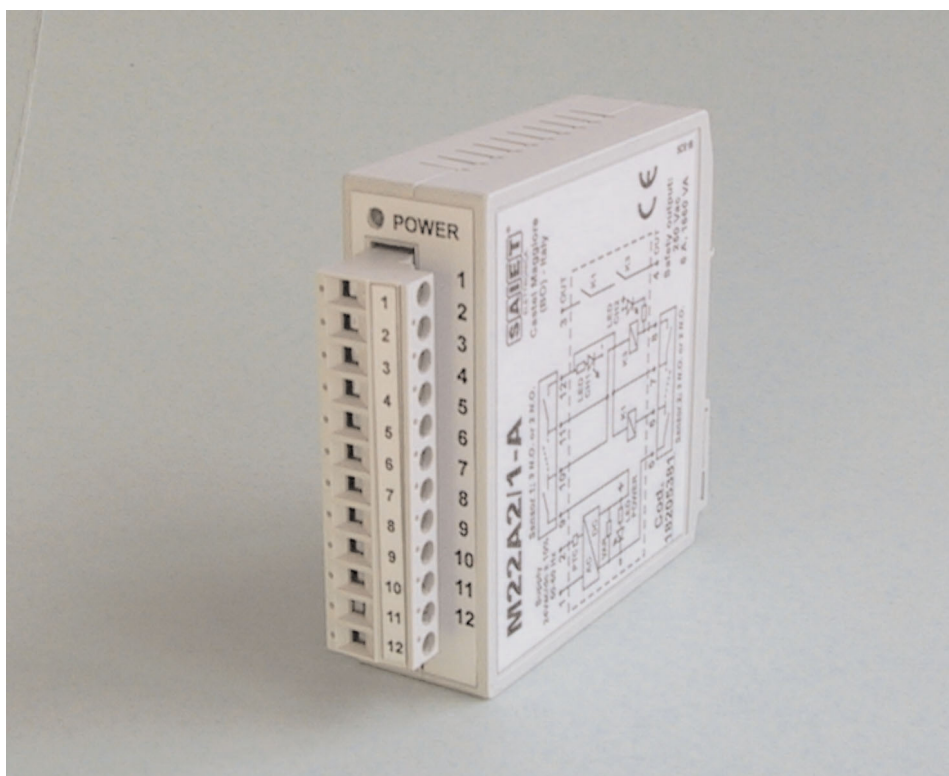

USER MANUAL

CARLO GAVAZZI

SAIET Elettronica S.p.A. - A Member of CARLO GAVAZZI Group
Via Serenari, 1 - 40013 Castel Maggiore (BO), Italy
Tel. +39 051 4178811 - Fax +39 051 4178800
<http://www.saiet.it/elettronica> e-mail: sales.el@saiet.it



Contents

| | |
|--|-----------|
| 1. INTRODUCTION | 3 |
| 2. PACKAGE CONTENTS | 4 |
| 3. CONTROL UNIT FUNCTIONS | 4 |
| 4. REFERENCE STANDARDS | 4 |
| 5. SAFETY CATEGORY | 4 |
| 6. TECHNICAL DATA | 5 |
| 7. INSTALLATION | 7 |
| 7.1 Warnings | 7 |
| 7.2 Wiring | 7 |
| 7.3 Installation examples | 9 |
| 8. INSTALLATION PROCEDURE | 11 |
| 9. USAGE PRECAUTIONS | 12 |
| 10. REGULAR INSPECTIONS AND MAINTENANCE | 13 |

1. INTRODUCTION

This “User Manual” must be read and understood completely, prior to carrying out any operation on the module, by personnel dealing with all the activities of the **M22A2/1-A** safety module. It must be stored in a dry clean place close to where the module is used for easy consultation. All the operations described in this manual must be carried out by carefully following all the indications given exclusively by specialised personnel. Contact SAIET Elettronica and do not carry out any operations on the safety module, ensuring the safety of the operators, if there are any doubts over the contents of this manual, or if there is a fault or a malfunction.

The user of the module is responsible for the evaluation of the risks of the entire system. Based on the evaluation and on the standards in force in the country of use, the user decides with complete responsibility that the functions described in the user manual are suitable for use on his machine.

He must also ensure that the installation, the wiring and the regular inspections take place according to the requested risk reduction level.

The distance of the guard, connected to the safety device, from the dangerous area, must be calculated on the basis of the machine stop time, including the response time of the device (see technical data: Response time), so that the operator cannot reach any parts still moving.

Whenever the **M22A2/1-A** module is improperly used, by not following only and all the indications of this manual or whenever these indications are partially, incorrectly or incompletely applied by personnel unspecialised and/or insufficiently informed on the contents of this manual and the machine safety directives, SAIET Elettronica is not responsible for the functioning of the module and its capacity to guarantee the operator’s safety.

The **M22A2/1-A** module does not require internal maintenance: if it is tampered or if the case is opened, the module loses its safety functions and the guarantee is annulled.

2. PACKAGE CONTENTS

The package contains :

- 1 safety module model **M22A2/1-A**;
- 1 12 poles female terminal board for coupling on the module;
- 1 user manual.

If any anomalies are found with the package, its contents or with the safety module, do not install and contact SAJET Elettronica.

3. CONTROL UNIT FUNCTIONS

The **M22A2/1-A** control unit permits the use, in input, of emergency stop (E-STOP) devices and guards controls, as shown in Table 1 and according to the connection diagrams set out in the examples of this user manual.

The **M22A2/1-A** safety module is used only for the automatic start: when the input channels close the safety outputs close.

4. REFERENCE STANDARDS

The reference standards are set out in Table 2.

| STANDARD | YEAR |
|------------|------|
| EN 954-1 | 1998 |
| EN 292-1 | 1991 |
| EN 292-2 | 1991 |
| EN 60204-1 | 1998 |
| EN 418 | 1992 |
| EN 1088 | 1995 |

Table 2 : Reference standards summary

5. SAFETY CATEGORY

The **M22A2/1-A** module conforms to the requirements of the safety category 1 according to EN 954-1.

| FUNCTION | PROTECTION DEVICE |
|--------------------------------|---|
| Emergency Stop (E-STOP) | E-STOP pushbutton/s with 1 or 2 positive mode actuation contacts with locking (Each features 1 or 2 closed contacts with pushbutton not pressed ⇒ safety condition) |
| Guards controls | Mechanical limit switches, or one/two/three channel coded magnetic safety sensor/s (Each features one/two/three closed contacts with guard closed ⇒ safety condition)(*) |

(*) According to the indications of the EN 1088 standard

Table 1: Functions carried out by the control unit

6. TECHNICAL DATA

| GENERAL FEATURES | VALUES |
|--|---|
| Supply voltage | 24 Vac \pm 10% 50 \div 60 Hz, 24 Vdc \pm 10% |
| Current consumption | 50 mA (@ 24 Vdc without load) |
| Power consumption | \leq 2 VA |
| Inputs | 2 inputs, each with 4 terminals (contacts voltage free) |
| Resistance permitted on the input terminals (6,7,8,10,11,12) | < 40 Ohm |
| Safety category (EN 954-1) | Up to 1 (depending on the installation) |
| Emergency stop category (EN 60204-1) | 0 |
| Short circuit protection | PTC 300 mA (internal) |
| Housing | NYLON Flammability class VO-UL94 –RAL 7035 |
| Terminal board (male and female) | 12 terminals in PA 6.6 Flammability class VO-UL94 |
| Fixing | OMEGA-DIN EN 50022 guide |
| <u>Degree of protection:</u> Safety module | IP-30 |
| Installation location module | IP-54 |
| Electromagnetic compatibility | EN 50081-1; EN 50082-2; |
| Operating temperature | 0 \div 55°C |
| Storage temperature | -25 \div 55°C |
| Relative operating humidity | 30 \div 95% |
| Relative storage humidity | 30 \div 95% |
| Cable section that can be connected to the terminals | Max 2.5 mm ² (rigid) Max 1.5 mm ² (flexible) |
| Dimensions (LxDxH) (including female terminal board) | 82 x 26 x 101 mm |
| Torque setting on connection terminals | 0.5 Nm |
| Weight (module + terminal board) | 120 g |

| TIMINGS | VALUES |
|--|---------------|
| Response time (Guard open/ E-STOP pushbutton pressed ⇒ safety output open) | ≤ 25 ms |
| START procedure delay (Guard closed/ E-STOP pushbutton reset ⇒ safety output closed) | ≤ 25 ms |
| Contemporaneity (in closing) between the two input channels | ∞ |

| SAFETY OUTPUTS | VALUES / FEATURES |
|--------------------------------------|---|
| Function | Contacts open: safety outputs disabled (danger or lack of power condition) Contacts closed: safety outputs enabled (safety condition for the operator) |
| Maximum switching voltage | 250 Vac |
| Maximum switching current | 6 A |
| Maximum switching power (ohmic load) | 1660 VA |
| Contacts protection | External fuse: delayed 4A / fast 6A |
| Mechanical life | > 10 ⁷ switchings |
| Electrical life (with maximum load) | > 10 ⁵ switchings |

| LED WARNINGS | VALUES | |
|---------------------|--------------------------------------|------------------------------------|
| | ON | OFF |
| POWER | module powered | module not powered |
| CH1 | contacts on inputs 9-10-11-12 closed | contacts on inputs 9-10-11-12 open |
| CH2 | contact on inputs 5-6-7-8 closed | contacts on inputs 5-6-7-8 open |

Table 3: Technical Data

7. INSTALLATION

7.1 Warnings

- The **M22A2/1-A** module must be installed following the standards in force in the country of use, when the machine is not powered and with no dangers for the operator, on the machine's electrical board in a dry and clean place, fixed on the special DIN rail.
- The module must be installed in an electrical board with a minimum protection degree equal to IP54.
- Ensure that close to the module installation point there are no conductors, cables or free materials that can come into contact with the module.
- To avoid interference due to coupling, run the limit switches connecting conductors separately from the power conductors.
- Ensure that the machine can operate in temperature and humidity conditions according to the technical data of this manual.
- Avoid installation during storms.
- Do not dispose of the packaging in the environment.

7.2 Wiring

It is recommended to use conductors with section and length adequate to the currents and distances involved, ensuring that the conductors are not excessively tight, that their positioning avoids potential cuts or squashing and that they are not in the way of people or things.

The **M22A2/1-A** module is connected through the 12 poles female terminal board supplied. It is recommended to carry out the wiring by removing the terminal board, connecting the cables and then reconnecting the terminal board on the male connector fitted to the safety module ensuring that all the pins make contact correctly.

The **M22A2/1-A** safety module can be connected and used with mechanical limit switches or coded magnetic sensors (according to EN 1088 standard), or with one/two channel E-STOP pushbuttons. In any case the contacts supplied to the module input must **all** be:

- **open** (equivalent to an open circuit) in case of a dangerous situation for the operator (guard open and/or E-STOP pushbutton pressed), or
- **closed** (equivalent to a short circuit) in case of an absence of dangerous situation for the operator (guard closed and/or E-STOP pushbutton not pressed).

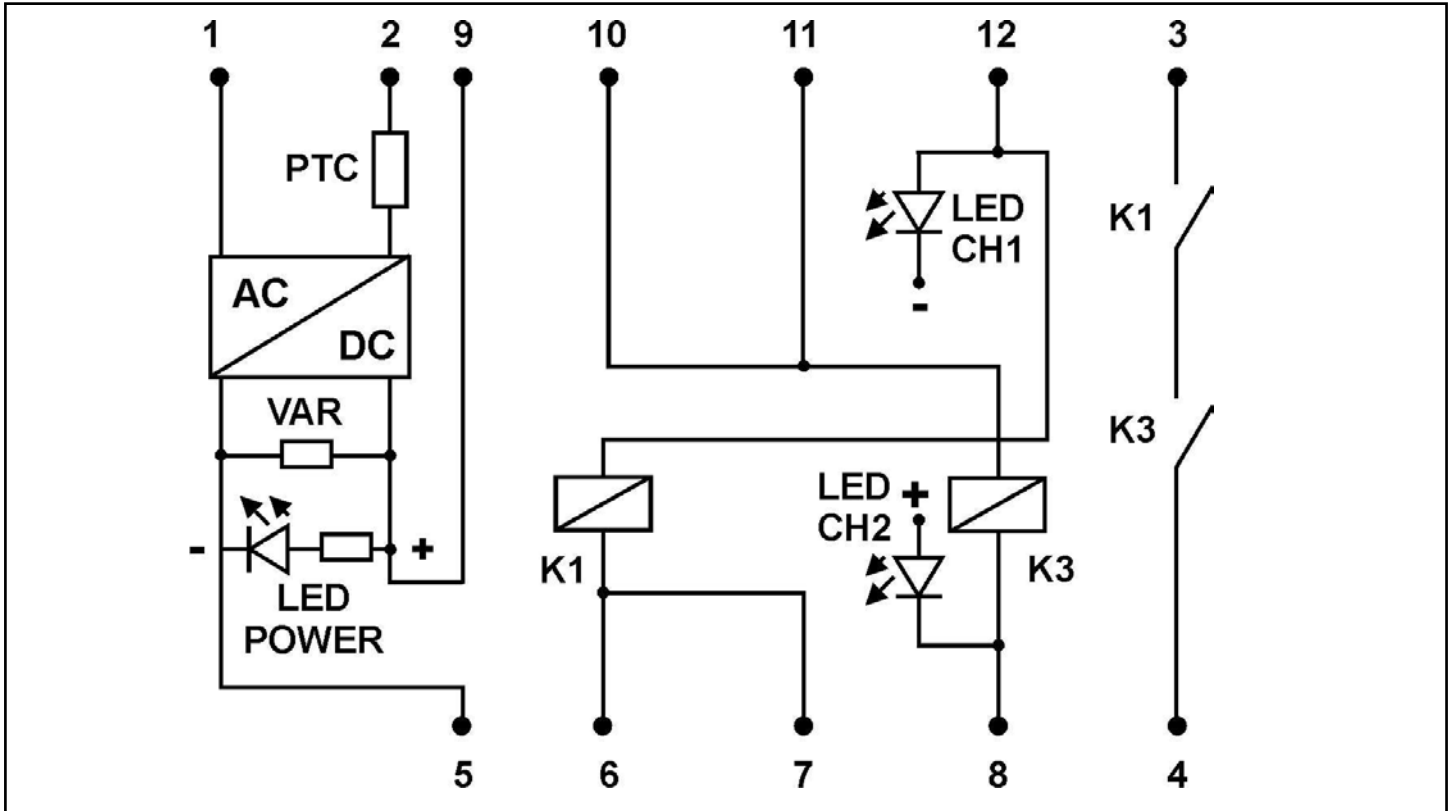

Fig. 1 – M22A2/1-A module block diagram

| TERMINAL | FUNCTION / CONNECTION |
|---------------|---|
| 1 | Power supply: +24Vdc / 24Vac |
| 2 | Power supply: GND / 24Vac |
| 5, 6, 7, 8 | First input (E-STOP pushbutton / limit switch / sensor contacts): <i>CLOSED</i> with the E-STOP pushbutton not pressed / guard closed ⇒ machine start enabled condition; <i>OPEN</i> with the E-STOP pushbutton pressed / guard open ⇒ machine start disabled condition |
| 9, 10, 11, 12 | Second input (E-STOP pushbutton / limit switch / sensor contacts): <i>CLOSED</i> with the E-STOP pushbutton not pressed / guard closed ⇒ machine start enabled condition; <i>OPEN</i> with the E-STOP pushbutton pressed / guard open ⇒ machine start disabled condition |
| 3 – 4 | Safety output : contact OPEN in case of lack of power supply danger; CLOSED in safety condition. |

Table 4: M22A2/1-A module functions of the terminals

The contacts of the input devices can have a resistance in series (see the application diagrams of this manual). The value of the resistance depends on the chosen configuration for the inputs: the safety module functions correctly with any inputs configuration having a series resistance less than 40 Ohm, as set out in this manual. For different series resistance and/or input configurations, contact SAIET Elettronica for compatibility instructions.

Opening even just one input contact (except for contact 2 of the figure) leads to a safety situation, forcing the safety output into an opening status (open circuit) and preventing its closure.

The closure of both inputs immediately starts the machine in automatic mode (Automatic START).

The user is completely responsible for choosing the devices to connect to the M22A2/1-A module, evaluating the risks and deciding the devices, that along with the module, will guarantee the requested safety category.

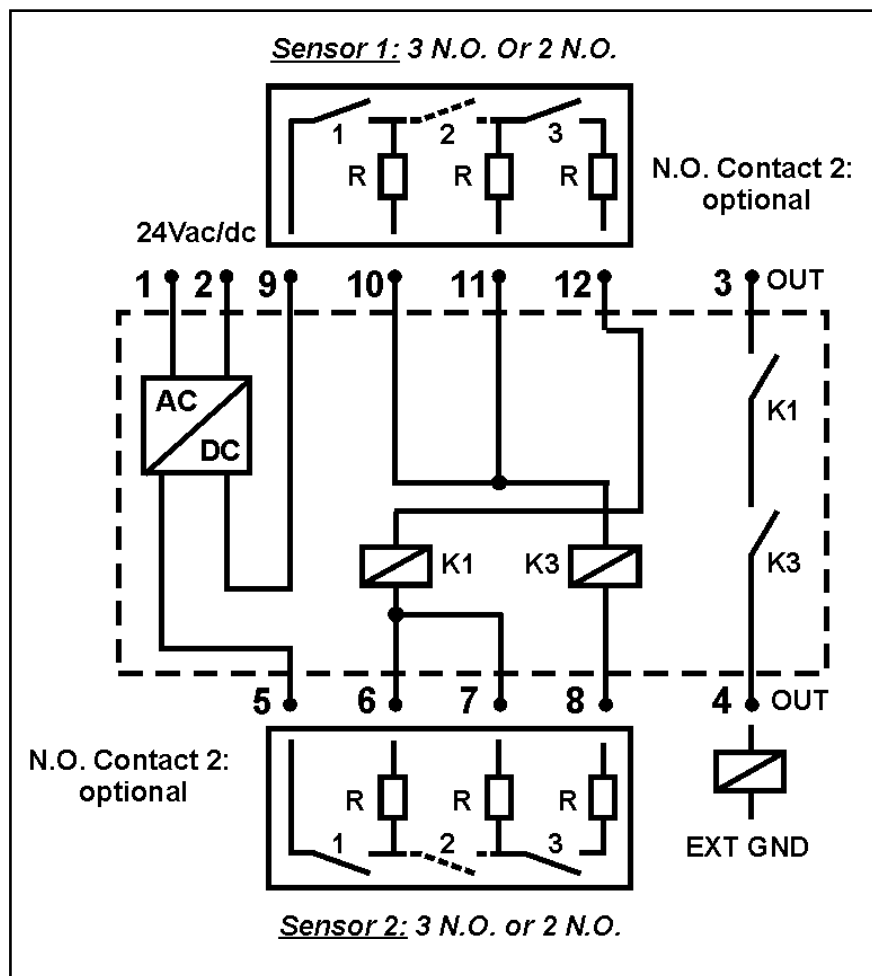

Fig. 2

7.3 Installation Examples

(The applications display the configurations with the E-STOP pushbutton/s not pressed and guard/s open).

The applications in figures 2, 3, 4, 5, 6, 7 illustrate possible methods of use and connections for the M22A2/1-A safety module. One or more sensors or emergency stop pushbuttons can be connected to the inputs. The sensors can have 1, 2 or 3 N.O. type of contacts (contact open with guard open) according to the configurations.

Figure 2 and Figure 4 illustrate the connection with sensors with 2 or 3 N.O. contacts.

In this configuration, the 2nd contact of each sensor is defined as “optional” as it can be made up of:

- a N.O. contact, or
- a short-circuit (e.g. SAIET Elettronica SMS-A2P-30 II model) or
- an open circuit (e.g. SAIET Elettronica SMS-03 family).

Such a configuration renders the input circuit adaptable to different types of sensors.

Figure 3 illustrates a possible connection with coded safety sensors with a single N.O. channel (for example SAIET SMS-A2P-10 or equivalent).

Figure 5 and 6 illustrate the application of one or two two-channel emergency stop pushbuttons.

Figure 7 illustrates the connection with a single channel emergency stop pushbutton.

More than one device can be connected in series to the input channels, maintaining the whole system in category 1, as long as the external devices used and the relative wiring are suitable to achieve this category and the

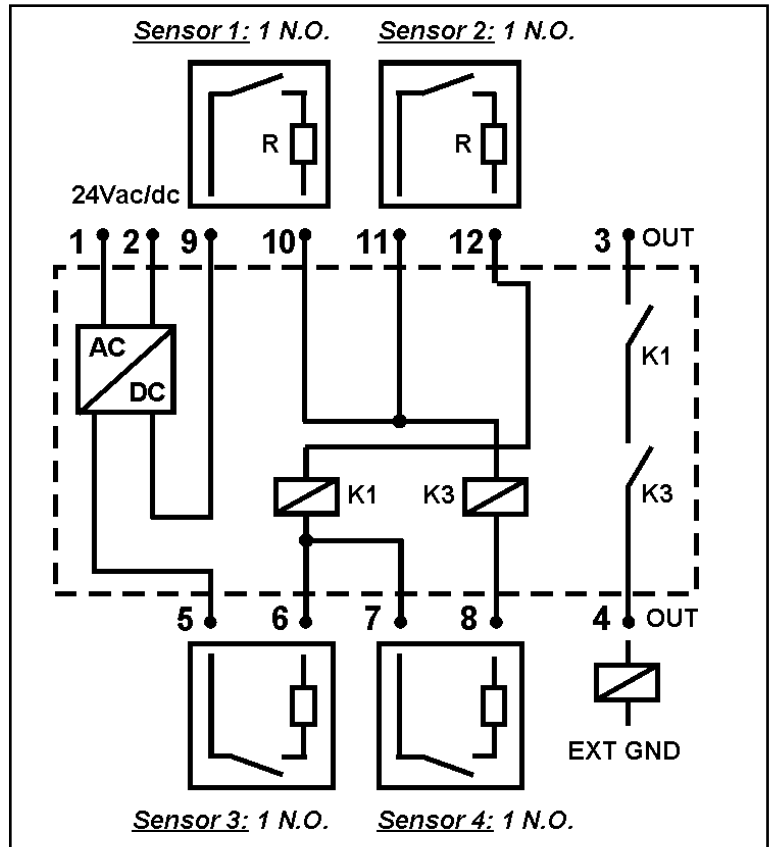

Fig. 3

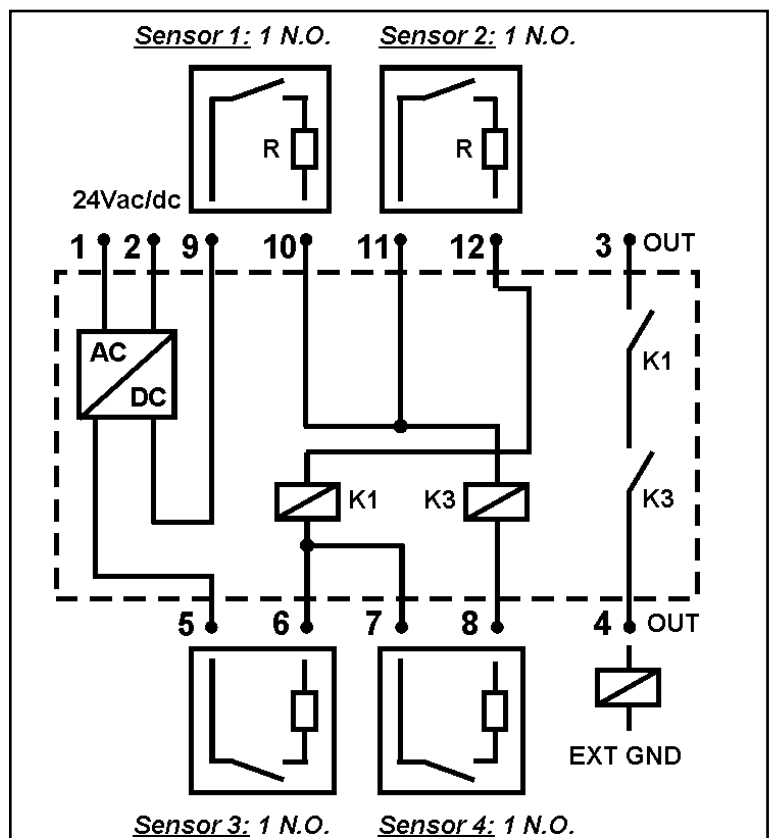

Fig. 4

total resistance values on the inputs do not exceed the declared limits (see TECHNICAL DATA).

For every other type of input or module configuration contact SAIET Elettronica.

8. INSTALLATION PROCEDURE

The safety module installation procedure must be repeated every time it is installed and every time the wiring is changed and at regular intervals by carrying out *in sequence all* the operations described below without any type of dangerous condition for the operators.

STEP 1: Check of the wirings and of the assembly

The inspection includes the visual control, the integrity control, the correct positioning on the machine control, the correct installation control and the correct functioning of all the devices (E-STOP pushbuttons, safety limit switches, external contactors) that control or are controlled by the **M22A2/1-A** safety module as well as the correct tightening of the cables and that they are not squashed or excessively pulled.

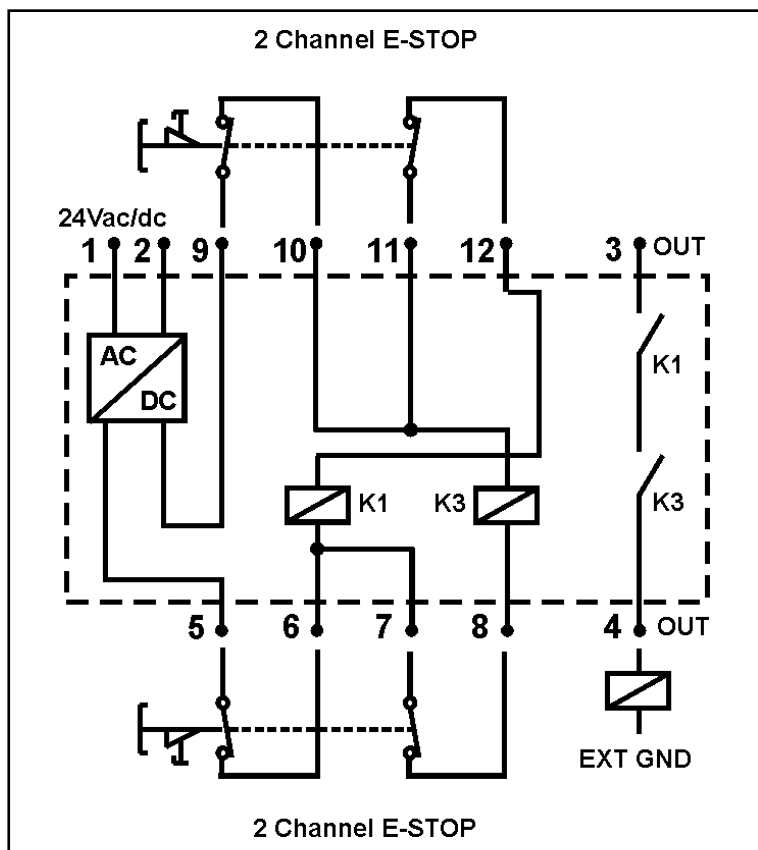

Fig. 5

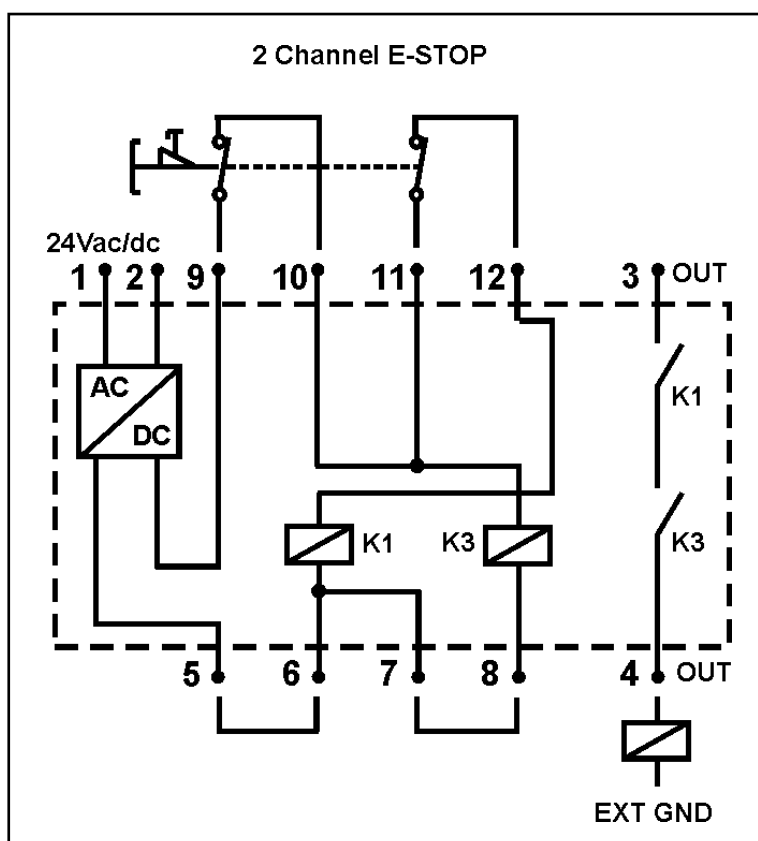

Fig. 6

STEP 2: Activation

- Connect the power supply to the terminals **1** and **2** and check that the safety output is open, the **POWER** LED is on and the **CH1** and **CH2** LED are off.
- Unlock the E-STOP pushbutton/close the guard on inputs **5, 6, 7, 8** (1st E-STOP or guard) and check that the safety output is open, the **POWER, CH2** LED are on and the **CH1** LED is off.
- Unlock the E-STOP pushbutton/close the guard on inputs **9, 10, 11, 12** (2nd E-STOP or guard) and check that the safety output is closed, the **POWER, CH1** and **CH2** LED are on.

STEP 3: Safety function check

- Press the E-STOP pushbutton/open the guard (1st E-STOP or guard) and check that the safety output opens, that the **POWER** and **CH1** LED are on and the **CH2** LED is off.
- Unlock the E-STOP pushbutton/close the guard (1st E-STOP or guard): check that the safety output is closed and the **POWER, CH1, CH2** LED are on.
- Press the E-STOP

pushbutton/open the guard (2nd E-STOP or guard) and check that the safety output opens, that the **POWER** and **CH2** LED are on and the **CH1** LED is off.

Repeat all the step 3 operations for each sensor, pushbutton or limit switch (e.g. application in figure 3) connected to the input terminals.

9. USAGE PRECAUTIONS

It is recommended to connect a fuse in series to the safety outputs to reduce the risk of the safety outputs contacts welding (see outputs technical data).

Never, in any situation, connect spark quenching unit circuits in parallel to safety outputs contacts: the safety function would no longer be guaranteed.

Never, in any circumstance, exceed the electrical rating indicated in the technical data table of this manual.

If the safety module does not reduce sufficiently the machine risks, the user must adopt other safety measures to physically prevent operator access to the dangerous zone.

The condition of safety outputs open indicates the presence of a fault or a dangerous condition for the operator. If the module opens its safety outputs the cause must be found. The machine can be

restarted once every cause of danger for the operators has been eliminated.

The **M22A2/1-A** module must be used for safety functions along with safety devices that conform to the standards applicable for such devices.

10. REGULAR INSPECTIONS AND MAINTENANCE

The integrity of the safety module and of all the parts connected to it must be checked regularly.

The frequency of the inspections depends on the typology of the machine on which the safety module is installed and therefore is part of the machine risks evaluation carried out by the person responsible for such evaluations.

Operator safety can be compromised by the lack of regular inspections or maintenance, or if they are carried out incorrectly, or by non specialised personnel, or at lower intervals than prescribed.

Regular inspections consist of carrying out an inspection of the wiring, of the installation and the integrity of the safety module, of its command and actuating devices and in repeating *all the operations* listed in the safety module **“INSTALLATION PROCEDURE”** section.

Maintenance also includes a regular cleaning of the safety module (dust and other substances must be removed from the module and it must be dried of liquids or any condensation) and of all integrated command or actuating devices connected, that must be carried out whilst the machine and module are rigorously not powered.



NOTES



SAIET Elettronica reserves the right to make improvements or changes without prior notice.