

Energy Management Modular Power Analyzers Type WM2-96



- Class 1
- Modular power analyzer
- Front size: 96x96 mm
- 3-dgt/6-dgt μ P-based indicator
- Manual or automatic scrolling of system and single phase: kW, kVAr, PF, kWh, kVArh, A, VL-L avg, VL1-N, VL2-N, VL3-N.
- TRMS measurement of distorted waves (voltage/current)
- All configuration functions selectable by built-in key-pad
- Password protection of programming parameters
- Degree of protection (front): IP 65
- Optional pulse output (according to DIN43864)
- Optional serial RS 422 /485 output
- MODBUS, JBUS protocol.

Product Description

μ P-based modular power analyzer with a built-in configuration key-pad. The power, power factor, current and voltage are system and sin-

gle phase measurements and indications. The housing is easy to mount on a panel and ensures a degree of protection (front) of IP 65.

Ordering Key **WM2-96 AV53DXXX**

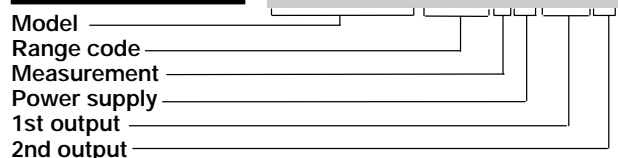

Type Selection

Range code	Measurement	Power supply	1st output (pulse)
AV5: 250/433 VAC - 5 AAC (max. 300 V (L-N)/ 520 V (L-L) - 6 A)	3: One phase, three-phase system, 3 or 4 wires, balanced load; three phase system, 3 or 4 wires, unbalanced load	A: 24 VAC, -15% +10%, 50/60 Hz ^{1) 2)}	XX: No output (standard)
AV7: 400/690 VAC - 5 AAC (max. 480 V (L-N)/ 830 V (L-L) - 6 A) ¹⁾		B: 48 VAC, -15%+10%, 50/60 Hz ^{1) 2)}	O1: Single open collector output (30V/100mADC) ¹⁾
		C: 115 VAC, -15% +10%, 50/60 Hz ^{1) 2)}	O2: Dual open collector output (30V/100mADC) ¹⁾
		D: 230 VAC, -15% +10%, 50/60 Hz (standard) ²⁾	R1: Single relay output, (AC1-8AAC, 250VAC) ¹⁾
		L: 18 to 60 VDC/AC ³⁾	R2: Dual relay output, (AC1-8AAC, 250VAC) ¹⁾
		H: 90 to 260 VDC/AC ³⁾	2nd output
			X: No output (standard)
			S: Serial output, RS 485 multidrop bidirectional ¹⁾

¹⁾ On request
²⁾ This power supply cannot be used if the RS485 module is needed
³⁾ Compatible with any kind of output

Input Specifications

Accuracy (48 to 62 Hz)	Un: 250V (AV5), 400V (AV7) In: 5A	Rated input	2 inputs (one/three-phase balanced load) 6 inputs (one/three-phase unbalanced load) 2 inputs (one/three-phase balanced load) 4 inputs (one/three-phase unbalanced load) among the voltage and the current inputs: 2000Vrms; among the current inputs: 2000 Vrms
Voltage/current (@ 25°C \pm 5°C, R.H. \leq 60%)	\pm 0.5% f.s. (0 to 1.2 In, 0.5 to 1.2 Un)	Current	
Active power/energy (@ 25°C \pm 5°C, R.H. \leq 60%)	\pm 1% f.s. (PF \geq 0.7 L/C, 0 to 1.2 In, 0.5 to 1.2 Un)	Voltage	
Reactive power/energy (@ 25°C \pm 5°C, R.H. \leq 60%)	\pm 1% f.s. (PF \geq 0.7 L/C, 0 to 1 In, 0 to 1 Un)	Insulation	
Power factor (PF) (@ 25°C \pm 5°C, R.H. \leq 60%)	\pm 1% f.s., PF \geq 0.7 L/C, (0.6 to 1.2 In, 1 to 1.2 Un)	Temperature drift	\pm 250 ppm/°C
Additional errors		Display	Backlighted LCD, h 13mm, 3-dgt (instantaneous meas.) 6-dgt (energies)
Humidity	< 0.3% f.s., 60% to 90% R.H.		
Power supply	\pm 0.5% rdg, -15 +10% p.s.		
Magnetic field	< 0.1% f.s. @ 400 A/m		

Input Specifications (cont.)

Decimal point position	Instantaneous measurements: Automatic selection according to the current transformer ratio of the CT being connected (max. indication - single phase): CT ratio $\leq 5 : 11.11$ (25.00A) CT ratio $\leq 50.0 : 111.1$ (250.0A) CT ratio $\leq 500.0 : 1111$ (2500A) CT ratio $\leq 999.9 : 11110$ (6000A) Energy measurements: max. resolution: 1 Wh/1 VARh min. resolution: 1 kWh/1 kVARh	Ranges (impedances)	250 V/433 V ($\geq 400k\Omega$) 5 AAC ($\leq 0.3 VA / \leq 0.1\Omega$) 400V/690V ($\geq 650k\Omega$)
Max. and min. indication		Frequency range	48 to 62 Hz
Voltage	Max. 600 min. 0	Over-load protection	Un: 250V (AV5), 400V (AV7) In: 5A 1.2 Un /In
Current (CT ratio = 1)	Max. 6.00 min. 0.00	Continuous: voltage/current For 1 s	
PF	Max. 1.00 min. 0.00	Voltage:	2 Un
Power (CT ratio = 1)	Max. 5.40 min. 0.00	Current:	20 In
Active energy	Max. 999999 min. -199999	Keyboard	4 keys: "Δ∇": - to enter programming phase and password confirmation; - for value programming and basic measurement scrolling. "L": - for confirmation of new programmed values and going ahead to the next programming step, - single phase measurement scrolling. "R": - for the reset of the partial counted active and/or reactive energy.
Reactive energy	Max. 999999 min. 0		
Sampling rate	3 times / second		
Measurements			
System variables	kW, kVAR, PF, V_{L-L} , A, kWh tot, kVARh tot, kWh partial, KVARh partial		
Single phase variables	kW, kVAR, PF, V_{L-N} , A		
Measurement method	TRMS measurement of a distorted voltage/current wave Coupling type: Direct Crest factor: ≥ 3		

Output Specifications

Pulse output (on request)		Data (bidirectional)	
Static type (according to DIN 43864)	From 0.1 to 999.9 programmable pulses for kWh, KVARh, open collector (NPN transistor) V_{ON} 1.2 VDC/ max. 100 mA V_{OFF} 30 VDC max.	Dynamic (reading only)	System variables: P, Q, PF, V_{L-L} , energies, Single phase variables: $PL1, QL1, PF1, VL1-N, AL1,$ $PL2, QL2, PF2, VL2-N, AL2,$ $PL3, QL3, PF3, VL3-N, AL3$
Relay type	1 x SPDT AC 1 - 8A, 250VAC DC 12 - 5A, 24VDC AC 15 - 2.5A, 250VAC DC 13 - 2.5A, 24VDC	Static (writing only)	All programming data, reset of energy: - partial kWh - partial kVARh - total kWh - total kVARh Stored energy (EEPROM) ≤ 999999 kWh ≤ 999999 kVARh
Pulse duration	200 ms (ON), ≥ 200 ms (OFF)		
Insulation	By means of optocouplers, 4000 V_{rms} output to measuring input, 4000 V_{rms} output to supply input.		
Serial output (on request)		Data format	1-start bit, 8-data bit, no parity/even parity, 1 stop bit
Type	RS422/RS485; Multidrop bidirectional (static and dynamic variables)	Baud-rate	1200, 2400, 4800 and 9600 selectable bauds
Connections	2 or 4 wires, max. distance 1200m, termination directly on the module	Insulation	By means of optocouplers, 4000 V_{rms} output to measuring inputs 4000 V_{rms} output to supply input
Addresses	1 to 255, selectable by key-pad		
Protocol	MODBUS/JBUS		

Software Functions

Password	Numeric code of max. 3 digits; 2 protection levels of the programming data Password "0", no protection Password from 1 to 255, all data are protected		Example: the CT is a 100A/5A so the ratio is 20, consequently the maximum counted energy is 299980 kWh or kVArh. Active power (kW), reactive power (kVAh), power factor (cos φ), current (A), phase-neutral voltage (V)
1st level 2nd level		Single phase:	
Measurement scrolling		Transformer ratio	For CT up to 5000 A
System:	Active power (kW), reactive power (kVAh), power factor (cos φ), current (A), average phase-phase voltage (V) total and partial active energy (kWh), total and partial reactive energy (kVArh) Partial energy meters: the counters of kWh and kVArh are automatically reset when the energy reaches the value (14999°CT).	Programmable ratio	0.1 to 999.9
		Digital Filter	
		Filter operating range	0 to 100% of the input electrical scale 1 to 64
		Filtering coefficient	On the display and on the variable being transmitted by the serial communication port.
		Filter action	

Supply Specifications

AC voltage	230 VAC (standard), -15%+10% 50/60 Hz 24 VAC, 48 VAC, 115 VAC (on request), -15%+10% 50/60 Hz 18 to 60VDC/AC	Power consumption	90 to 260VDC/AC ≤ 30VA / 12W (90 to 260V) ≤ 20VA / 12W (18 to 60V)
-------------------	--	--------------------------	--

General Specifications

Operating temperature	0° to +50°C (32° to 122°F) (R.H. < 90% non-condensing)	Safety standards	IEC 61010-1, EN 61010-1
Storage temperature	-10° to +60°C (14° to 140°F) (R.H. < 90% non-condensing)	Other standards	Pulse output: DIN43864
Insulation reference voltage	300 Vrms to ground	Approvals	UL (pending) CSA (pending)
Insulation	4000 Vrms between all inputs/outputs to ground	Connector	Screw-type, max. 2.5 mm ² wires x 2
Dielectric strength	4000 Vrms for 1 minute	Housing	
Noise rejection		Dimensions	96 x 96 x 140 mm
CMRR	100 dB, 48 to 62 Hz	Material	ABS, self-extinguishing: UL 94 V-0
EMC	EN 50 081-2, EN 50 082-2	Degree of protection	Front: IP65
		Weight	Approx. 500 g (packing included)

Mode of Operation

Accuracy class of the instrument as a relation of P_I/P_N and $\cos \varphi$ (power factor)

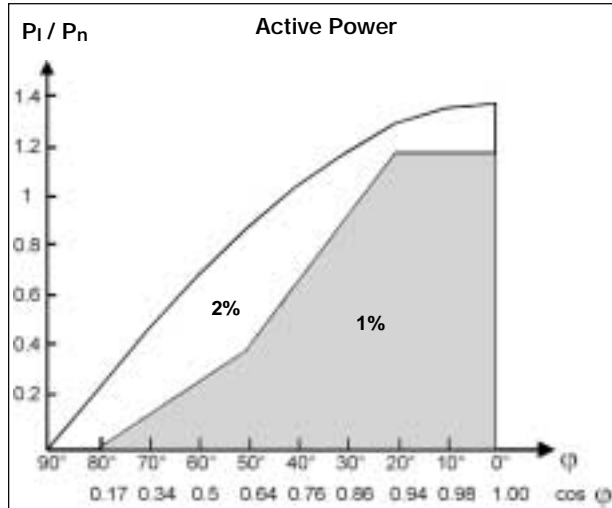

Test conditions:

$V = 0.8$ to $1.2 U_n$,
 $I = 0.1$ to $1.2 I_n$,
 $f = 48$ to 62 Hz

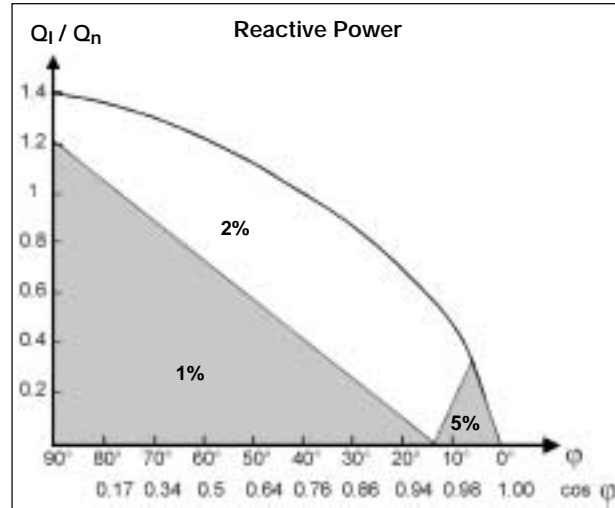

Test conditions:

$V = 0.8$ to $1.2 U_n$,
 $I = 0.1$ to $1.2 I_n$,
 $f = 48$ to 62 Hz

Input	Star voltage	Delta voltage	Current
AV5	U_n : 250 V	U_n : 430 V	I_n : 5 A

P_I/Q_I (installation power)

One phase system:

$$P_I = U_I \cdot I_I \cdot \cos \varphi$$

$$Q_I = U_I \cdot I_I \cdot \sin \varphi$$

Three phase, 3-wire system:

$$P_I = \sqrt{3} \cdot U_I \cdot I_I \cdot \cos \varphi$$

$$Q_I = \sqrt{3} \cdot U_I \cdot I_I \cdot \sin \varphi$$

Three phase, 4-wire system:

$$P_I = 3 \cdot U_I \cdot I_I \cdot \cos \varphi$$

$$Q_I = 3 \cdot U_I \cdot I_I \cdot \sin \varphi$$

where:

U_I = the real star voltage of the electrical system being measured.

I = the maximum phase current of the electrical system being measured.

$\cos \varphi$ = the average $\cos \varphi$ of the electrical system being measured.

P_N/Q_N (rated power of the instrument):

One phase system:

$$P_N = Q_N = U_n \cdot I_n \cdot CT(\text{ratio})$$

Three phase, 3-wire system:

$$P_N = Q_N = \sqrt{3} \cdot U_n \cdot I_n \cdot CT(\text{ratio})$$

Three phase, 4-wire system:

$$P_N = Q_N = 3 \cdot U_n \cdot I_n \cdot CT(\text{ratio})$$

where:

U_n = the rated input voltage of WM2-96.

I_n = the rated input current of WM2-96.

$CT(\text{ratio})$ = the value of the current transformer ratio.

Example 1:

Model AV5.3 (3-wire system).

$U_I = 400$ V (delta voltage)

$I_I = 265$ A (single phase current)

$\cos \varphi = 0.85$ (system power factor) (CT=300A)

$U_n = 430$ V

$I_n = 5$ A

$$CT(\text{ratio}) = \frac{300}{5} = 60$$

$$P_I = \sqrt{3} \cdot U_I \cdot I_I \cdot \cos \varphi$$

$$= \sqrt{3} \cdot 400 \cdot 265 \cdot 0.85$$

$$= 155.87 \text{ kW}$$

$$P_N = \sqrt{3} \cdot U_n \cdot I_n \cdot CT(\text{ratio})$$

$$= \sqrt{3} \cdot 430 \cdot 5 \cdot 60$$

$$= 233.17 \text{ kW}$$

$$\frac{P_I}{P_N} = \frac{155.87}{233.17} = 0.698$$

Example 2:

Model AV5.3 (4-wire system).

$U_I = 230$ V

$I_I = 110$ A (CT=300A)

$\cos \varphi = 0.85$ ($\sin \varphi = 0.52$)

$U_n = 250$ V

$I_n = 5$ A

$$CT(\text{ratio}) = \frac{300 \text{ A}}{5 \text{ A}} = 60$$

$$Q_N = 3 \cdot U_I \cdot I_I \cdot \sin \varphi$$

$$= 3 \cdot 230 \cdot 110 \cdot 0.52$$

$$= 39.46 \text{ kvar}$$

$$Q_N = 3 \cdot U_n \cdot I_n \cdot CT(\text{ratio})$$

$$= 3 \cdot 250 \cdot 5 \cdot 60$$

$$= 225 \text{ kvar}$$

$$\frac{P_I}{P_N} = \frac{39.46}{225} = 0.175$$

In both examples the accuracy of the measurement is 1% f.s. when considering the changing of the measured voltage from $0.9 U_n$ to $1 U_n$ and the measured current from $0.1 I_n$ to $0.9 I_n$ with a $\cos \varphi$ of 0.85 ($\sin \varphi$ 0.52).

Mode of Operation (cont.)

Waveform of the signals that can be measured

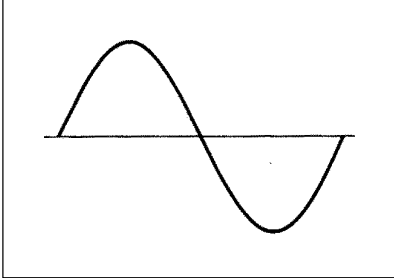

Figure G
Sine wave, undistorted
 Fundamental content 100%
 Harmonic content 0%
 $A_{rms} = 1.1107 | \bar{A} |$

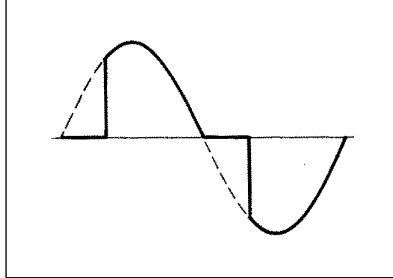

Figure H
Sine wave, indented
 Fundamental content 10...100%
 Harmonic content 0...90%
 Frequency spectrum 3rd to 16th harmonic
 Required result: additional error < 1%

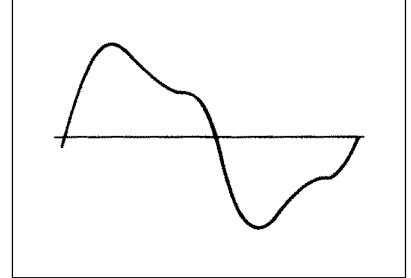
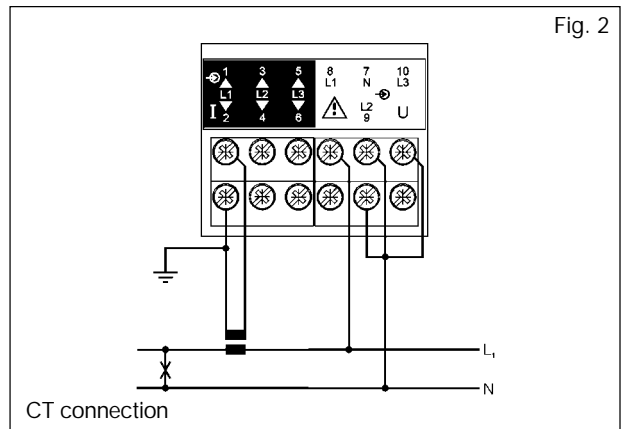
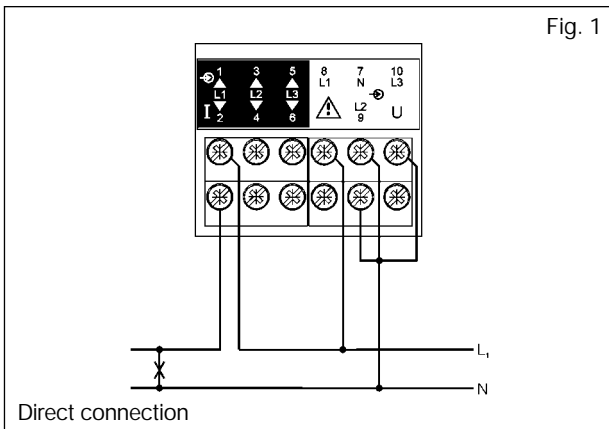

Figure I
Sine wave, distorted
 Fundamental content 70...90%
 Harmonic content 10...30%
 Frequency spectrum 3rd to 15th harmonic
 Required result: additional error < 0.5%

Wiring Diagrams

Single phase input connections



Three phase/3-wire input connections - Balanced loads

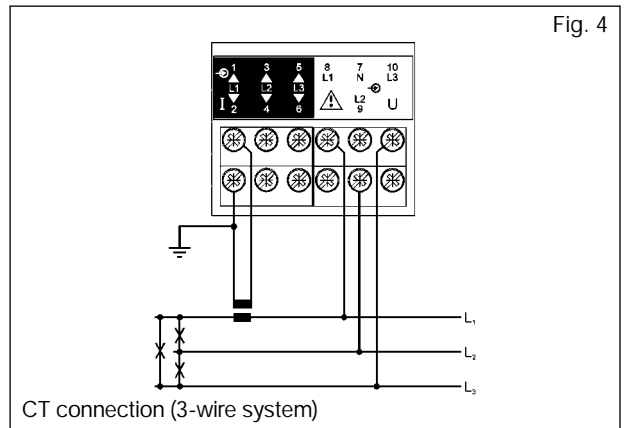
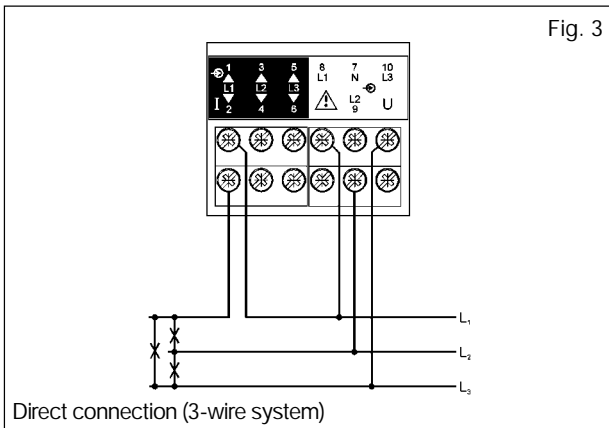

Wiring Diagrams (cont.)

Three phase, 4-wire input connections - Balanced loads

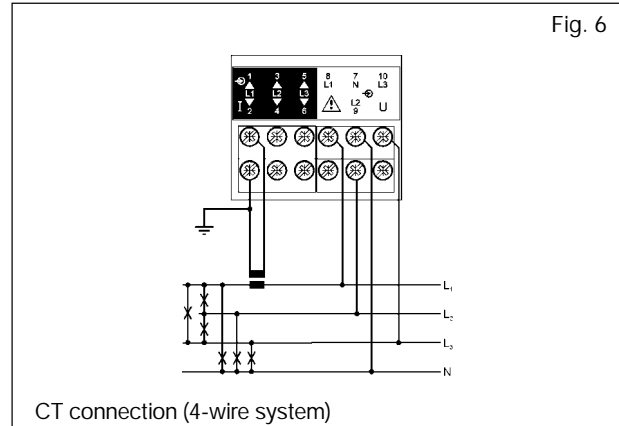
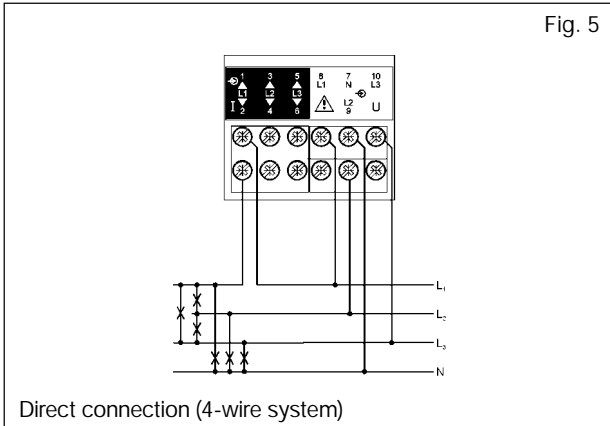

Three-phase, 3-wire input ARON connections - Unbalanced load

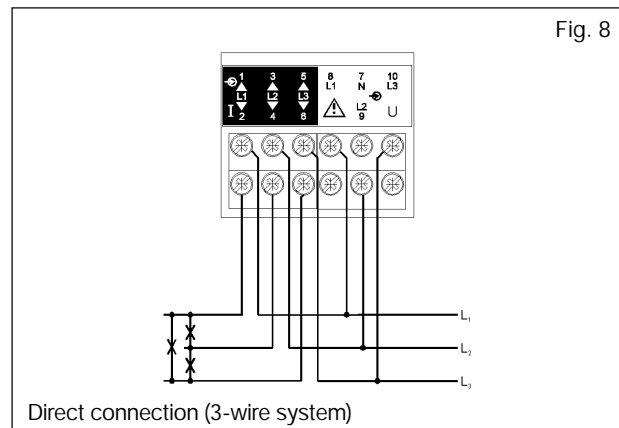
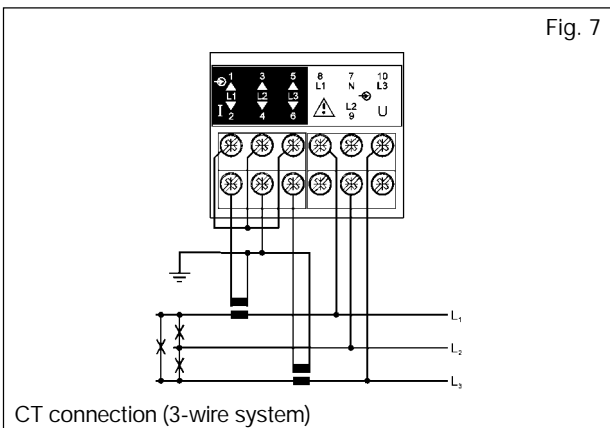

Three phase, 4-wire input connections - Unbalanced load

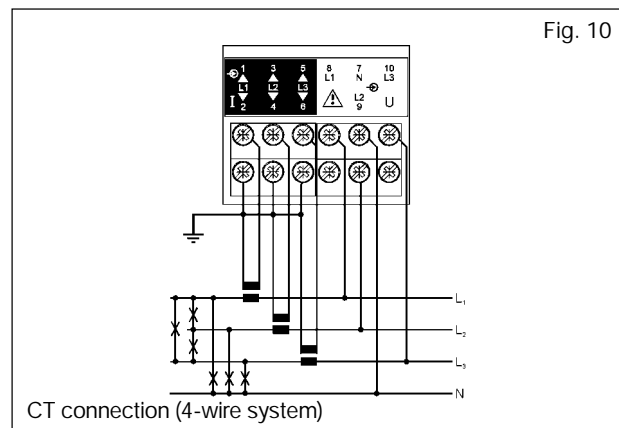
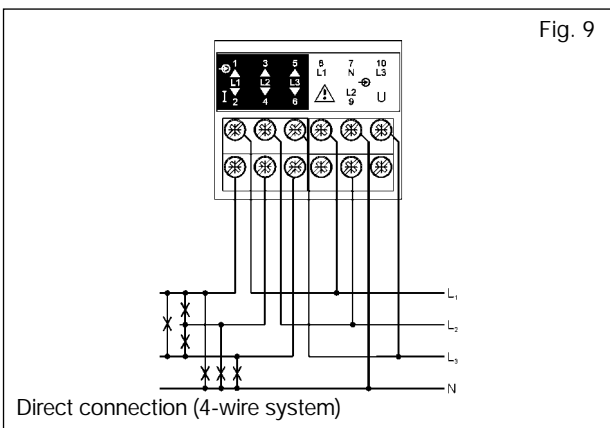

Front Panel Description

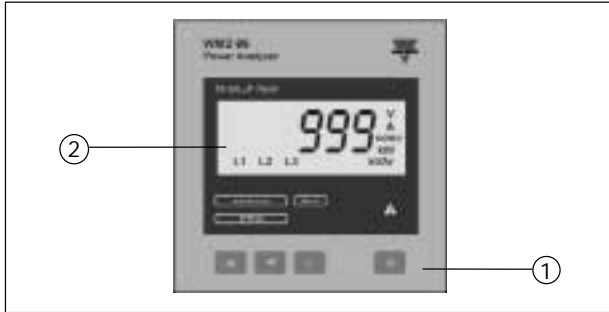

1. Key-pad

Set-up and programming procedures are easily controlled by the 4 pushbuttons.

"▲" and "▼"

- To scroll all the basic measurements (system variables)
- To increase or decrease programming values

- To enter into the programming procedure and select programming functions together with the "L" key.

"L":

To scroll all the single phase variable of each basic measurement

"R":

To reset the partial counted energies (kWh, kVARh).

2. Display

Instantaneous measurements:

- 3-digit (maximum read-out 999)

Energies:

- 6-digit (maximum read-out 999999).

Alphanumeric indication by means of LCD display for:

- Displaying the configuration parameters
- All the measured variables.

Sequence of the variables on the display

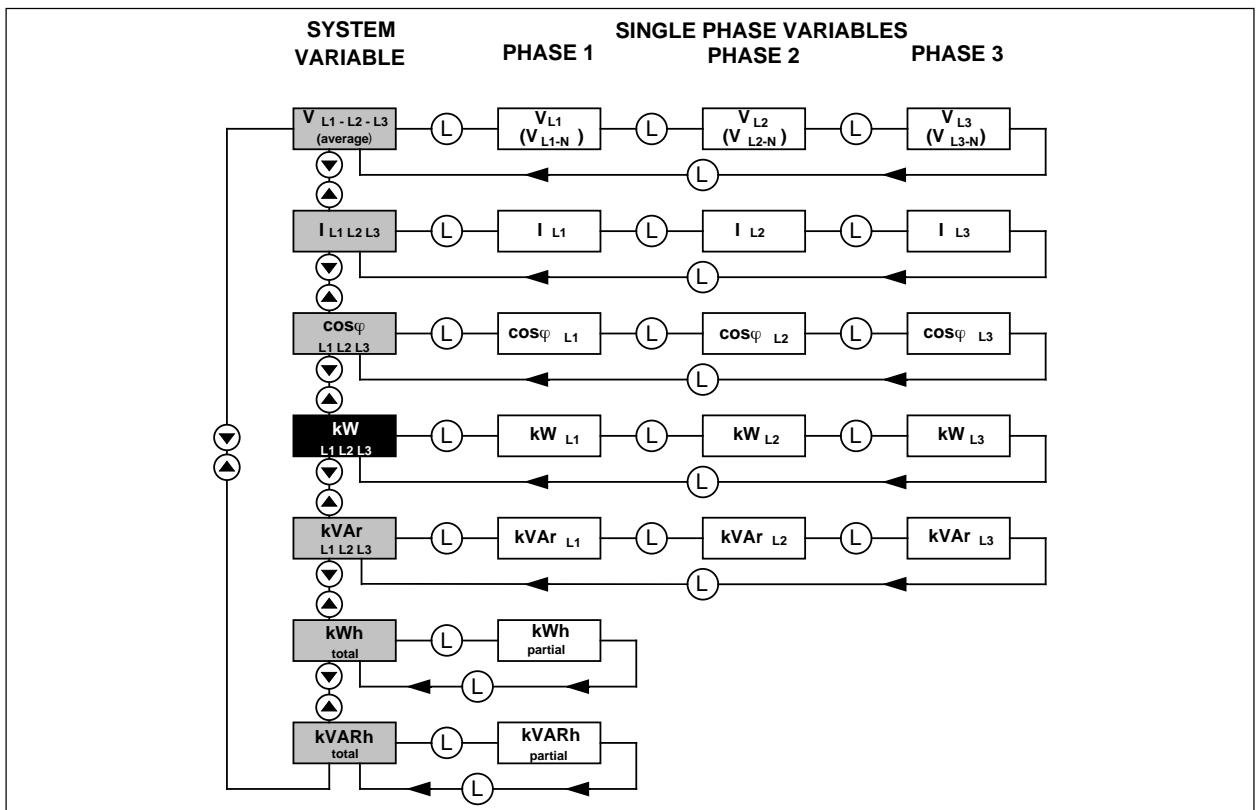

The available modules

Type	N. of channels	Ordering code	Note
WM2-96 base + AV5.3 input		AB1012	
WM2-96 base + AV7.3 input		AB1013	
24VAC power supply		AP1025	
48VAC power supply		AP1024	
115VAC power supply		AP1023	
230VAC power supply		AP1022	
18-60VAC/DC power supply		AP1021	
90-260VAC/DC power supply		AP1020	
RS485 output	1	AR1034	
Relay output	1	AO1058	
Relay output	2	AO1035	The second output can be used as redundant output
Open collector output	1	AO1059	
Open collector output	2	AO1036	The second output can be used as redundant output

The possible module combinations

Basic unit	Out 1	Out 2	Basic unit	Out 1	Out 2
RS485 output	●		RS485 output	●	
Single relay output (pulse)		●	Dual relay output (pulse)		●
Single open collector output (pulse)		●	Dual open collector output (pulse)		●

Dimensions

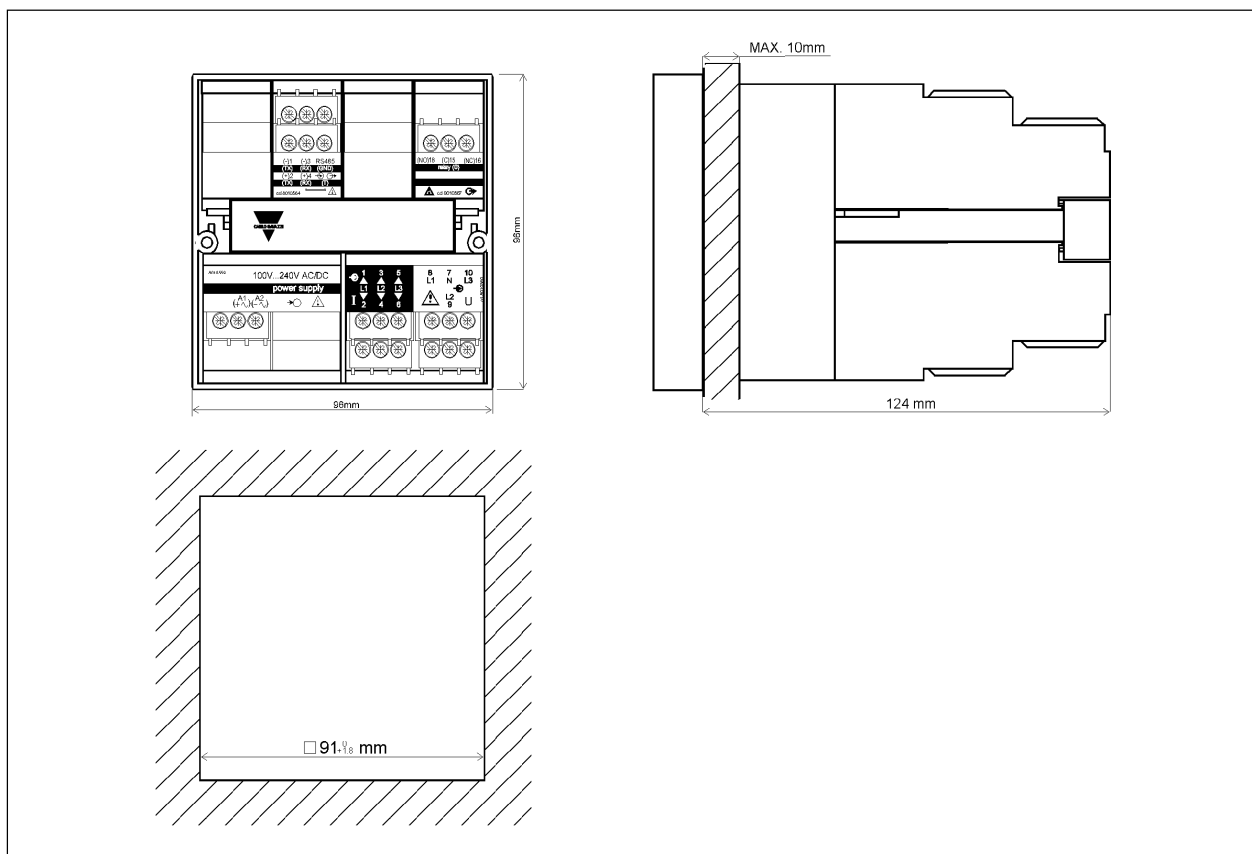

Terminal boards

Digital output modules

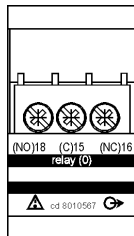

AO1058
Single relay output

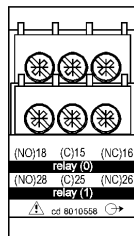

AO1035
Dual relay output

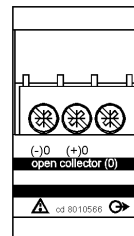

AO1059
Single open collector output

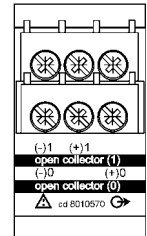

AO1036
Dual open collector output

Other input/output modules

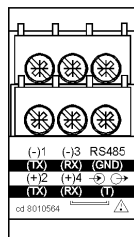

AR1034
RS485 output

Power supply modules

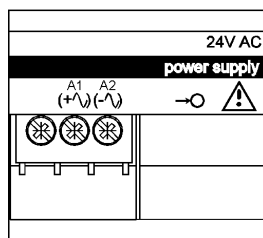

AP1025
24VAC power supply

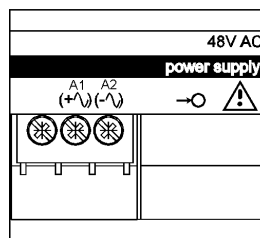

AP1024
48VAC power supply

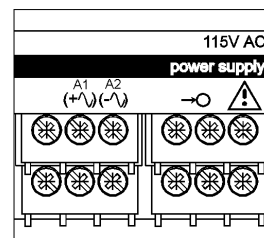

AP1023
115VAC power supply

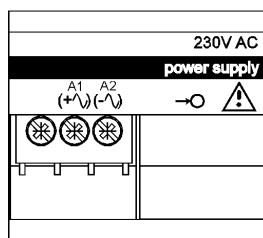

AP1022
230VAC power supply

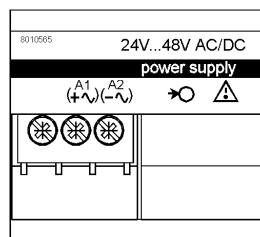

AP1021
18-60VAC/DC power supply

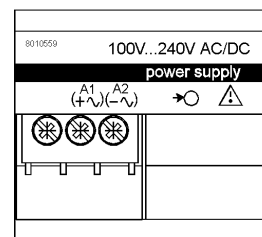

AP1020
90-260 VAC/DC power supply