

Power analyzers and Energy Meters

Multifunction indicator

Type WM12-96

CARLO GAVAZZI



- Accuracy ± 0.5 F.S. (current/voltage)
- Multifunction indicator
- Display of instantaneous variables: 3x3 digit
- Variable system and phase measurements: W, W_{dmd} , var, VA, VA_{dmd} , PF, V, A, An, Hz
- A_{max} , $W_{dmd\ max}$ indication
- TRMS meas. of distorted sine waves (voltages/currents)
- Power supply: 24V, 48V, 115V, 230V, 50-60Hz; 18 to 60VDC
- Protection degree (front): IP 50 (STD), IP65 on request
- Front dimensions: 96x96mm
- Optional RS422/485 serial output
- Alarms (visual only) V_{LN} , An

Product Description

3-phase multifunction power indicator with built-in programming key-pad. Particularly recommended for displaying the main electrical variables.

Housing for panel mounting, (front) protection degree IP50 as standard, IP65 on request and optional RS485 serial output.

How to order

WM12-96 AV5 3 D XX

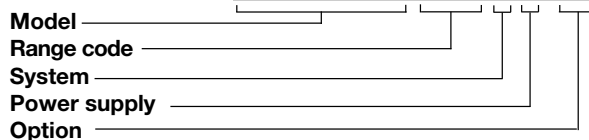

Type Selection

Range codes	System	Power supply	Options
AV5: 400/660V _{L-L} /5(6)AAC VL-N: 185 V to 460 V VL-L: 320 V to 800 V AV6: 100/208V _{L-L} /5(6)AAC VL-N: 45 V to 145 V VL-L: 78 V to 250 V Phase current: 0.03A to 6A Neutral current: 0.09 to 6A	3: 1-2-3-phase, unbalanced load, with or without neutral	A: 24VAC -15+10%, 50-60Hz B: 48VAC -15+10%, 50-60Hz C: 115VAC -15+10%, 50-60Hz D: 230VAC -15+10%, 50-60Hz 3: 18 to 60VDC	XX: None SX: RS485 output XI: IP65 protection degree

Input specifications

Rated inputs Current Voltage	3 (shunt) 4	Sampling rate 1400 samples/s @ 50Hz 1700 samples/s @ 60Hz
Accuracy (display, RS485) (@25°C $\pm 5^\circ\text{C}$, R.H. $\leq 60\%$)	with CT=1 and VT=1 AV5: 1150W-VA-var, FS:230VLN, 400VLL; AV6: 285W-VA-var, FS:57VLN, 100VLL	Display refresh time 700ms
Current Neutral current Phase-phase voltage Phase-neutral voltage Active and Apparent power, Power factor Reactive power Frequency	0.25 to 6A: $\pm(0.5\% \text{ FS} + 1\text{DGT})$ 0.03A to 0.25A: $\pm 7\text{DGT}$ 0.25 to 6A: $\pm(1.5\% \text{ FS} + 1\text{DGT})$ 0.09A to 0.25A: $\pm 7\text{DGT}$ $\pm(1.5\% \text{ FS} + 1 \text{ DGT})$ $\pm(0.5\% \text{ FS} + 1 \text{ DGT})$ 0.25 to 6A: $\pm(1\% \text{ FS} + 1\text{DGT})$; 0.03A to 0.25A: $\pm(1\% \text{ FS} + 5\text{DGT})$ 0.25 to 6A: $\pm(2\% \text{ FS} + 1\text{DGT})$; 0.03A to 0.25A: $\pm(2\% \text{ FS} + 5\text{DGT})$ $\pm 0.1\% \text{ Hz}$ (48 to 62Hz)	Display Type Read-out for the instant. var. Measurements Current, voltage, power, power factor, frequency TRMS measurement of distorted waves. Coupling type Crest factor Direct < 3 , max 10A peak
Additional errors Humidity Temperature drift	$\leq 0.3\% \text{ FS}$, 60% to 90% RH $\leq 200\text{ppm}/^\circ\text{C}$	Input impedance 400/660V _{L-L} (AV5) 100/208V _{L-L} (AV6) Current $1 \text{ M}\Omega \pm 5\%$ $453 \text{ K}\Omega \pm 5\%$ $\leq 0.02\Omega$ Frequency 48 to 62 Hz Overload protection Continuous voltage/current For 500ms: voltage/current 1.2 F.S. 2 Un/36A



RS485 Serial Output Specifications

RS422/RS485 (on request)			
Type	Multidrop bidirectional (static and dynamic variables)	Data (bidirectional) Dynamic (reading only) Static (writing only)	System and phase variables All configuration parameters
Connections	2 or 4 wires, max. distance 1200m, termination directly on the instrument	Data format	1 bit di start , 8 data bit, no parity, 1 stop bit
Addresses	1 to 255, key-pad selectable	Baud-rate	9600 bit/s
Protocol	MODBUS/JBUS		

Software functions

Password	Numeric code of max. 3 digits; 2 protection levels of the programming data Password "0", no protection	Displaying	Up to 3 variables per page Page 1: V L1, V L2, V L3 Page 2: V L12, V L23, V L31 Page 3: A L1, A L2, A L3 Page 4: An
1st level	Password from 1 to 999, all data are protected	3-phase system with neutral	Page 5: W L1, W L2, W L3 Page 6: PF L1, PF L2, PF L3 Page 7: var L1, var L2, var L3 Page 8: VA L1, VA L2, VA L3 Page 9: VA Σ , W Σ , var Σ Page 10: VA dmd, W dmd, Hz Page 11: Wdmd MAX Page 12: VL-L Σ , PF Σ Page 13: A MAX
2nd level			
System selection	3-phase with neutral 3-phase without neutral 3-phase ARON 2-phase Single phase		
Transformer ratio			
CT	1 to 999		
VT	1.0 to 99.9		
Filter		Alarms	Programmable, for the VL Σ and An (neutral current). Note: the alarm is only visual, by means of LED on the front of the instrument.
Operating range	0 to 99.9% of the input electrical scale		
Filtering coefficient	1 to 16	Reset	Independent alarm (VL Σ , An) max: A, Wdmd
Filter action	Measurements, alarms, serial output (fundamental variables: V, A, W and their derived ones).		

Power Supply Specifications

Auxiliary power supply	230VAC -15 +10%, 50-60Hz 115VAC -15 +10%, 50-60Hz 48VAC -15 +10%, 50-60Hz	Power consumption	24VAC -15 +10%, 50-60Hz 18 to 60VDC AC: 4.5 VA DC: 4W
-------------------------------	------------------------------------------------------------------------------------------	--------------------------	-------------------------------------------------------------------

General Specifications

Operating temperature	0 to +50°C (32 to 122°F) (RH < 90% non condensing at 40°C)		500VAC/DC between measuring inputs and RS485. 4000VAC, 500VDC between power supply and RS485
Storage temperature	-10 to +60°C (14 to 140°F) (RH < 90% non condensing at 40°C)	Dielectric strength	4000 VAC (for 1 min)
Installation category	Cat. III (IEC 60664, EN60664)	EMC	
Insulation (for 1 minute)	4000VAC, 500VDC between measuring inputs and power supply.	Emissions	EN50084-1 (class A) residential environment, commerce and light industry

General Specifications (cont.)

Immunity	EN61000-6-2 (class A) industrial environment.	Material	ABS self-extinguishing: UL 94 V-0
Pulse voltage (1.2/50µs)	EN61000-4-5	Mounting	Panel
Safety standards	IEC60664, EN60664	Protection degree	Front: IP50 (standard) Front: IP65 (on request) Connections: IP20
Approvals	CE, UL	Weight	Approx. 400 g (pack. incl.)
Connections 5(6) A Max cable cross sect. area	Screw-type 2.5 mm ²		
Housing Dimensions (WxHxD)	96 x 96 x 63 mm		

Waveform of the signals that can be measured

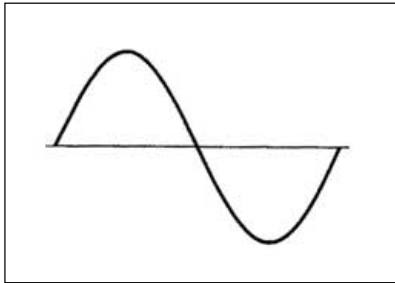

Figure D
Sine wave, undistorted
Fundamental content 100%
Harmonic content 0%
 $A_{rms} = 1.1107 | \bar{A} |$

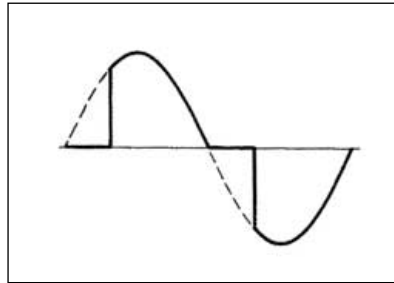

Figure E
Sine wave, indented
Fundamental content 10...100%
Harmonic content 0...90%
Frequency spectrum: 3rd to 16th harmonic
Additional error: <1% FS

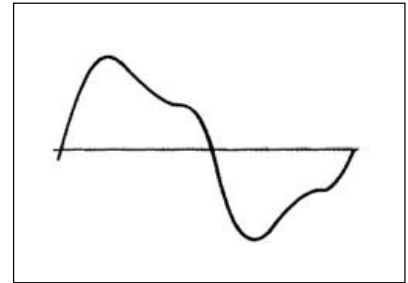

Figure F
Sine wave, distorted
Fundamental content 70...90%
Harmonic content 10...30%
Frequency spectrum: 3rd to 16th harmonic
Additional error: <0.5% FS

Display pages

Display variables in 3-phase systems (in a 3-phase system with neutral)

No	1 st variable	2 nd variable	3 rd variable	Note
1	V L1	V L2	V L3	
2	V L12	V L13	V L31	Decimal point blinking on the right of the display
3	A L1	A L2	A L3	
4	An	AL.n		AL.n if neutral current alarm is active
5	W L1	W L2	W L3	Decimal point blinking on the right of the display if generated power
6	PF L1	PF L2	PF L3	
7	VAR L1	VAR L2	VAR L3	Decimal point blinking on the right of the display if generated power
8	VA L1	VA L2	VA L3	
9	VA system	W system	VAR system	
10	VA dmd (system)	W dmd (system)	Hz (system)	dmd = demand (integration time selectable from 1 to 30 minutes)
11		W dmd MAX		Maximum sys power demand
12	V LN dmd	AL.U	PF system	AL.U= is activated only if one of VLN is not within the set limits
13	A MAX			max. current among the three phases



Used calculation formulas

Phase variables

Instantaneous effective voltage

$$V_{IN} = \sqrt{\frac{1}{n} \cdot \sum_1^n (V_{INi})^2}$$

Instantaneous active power

$$W_1 = \frac{1}{n} \cdot \sum_1^n (V_{INi}) \cdot (A_{1i})$$

Instantaneous power factor

$$\cos\phi_1 = \frac{W_1}{VA_1}$$

Instantaneous effective current

$$A_1 = \sqrt{\frac{1}{n} \cdot \sum_1^n (A_{1i})^2}$$

Instantaneous apparent power

$$VA_1 = V_{IN} \cdot A_1$$

Instantaneous reactive power

$$VAR_1 = \sqrt{(VA_1)^2 - (W_1)^2}$$

System variables

Equivalent 3-phase voltage

$$V_L = \frac{V_1 + V_2 + V_3}{3} \cdot \sqrt{3}$$

3-phase reactive power

$$VAR_L = (VAR_1 + VAR_2 + VAR_3)$$

3-phase active power

$$W_L = W_1 + W_2 + W_3$$

3-phase apparent power

$$VA_L = \sqrt{W_L^2 + VAR_L^2}$$

3-phase power factor

$$\cos\phi_L = \frac{W_L}{VA_L}$$

Neutral current

$$A_n = \bar{A}_{L1} + \bar{A}_{L2} + \bar{A}_{L3}$$

Wiring diagrams

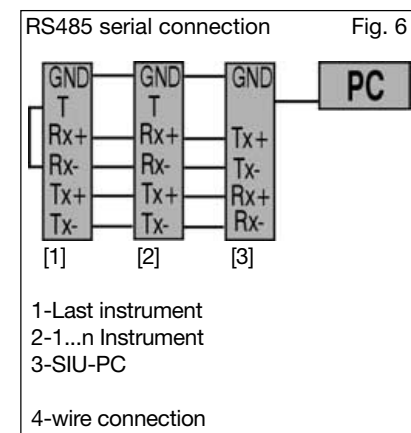
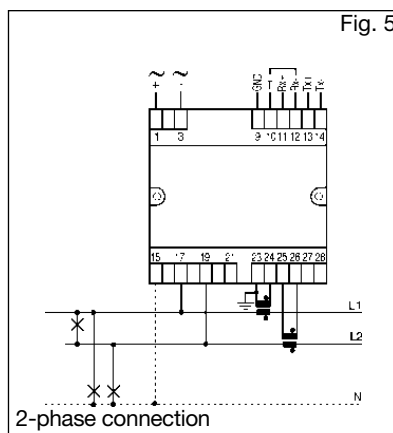
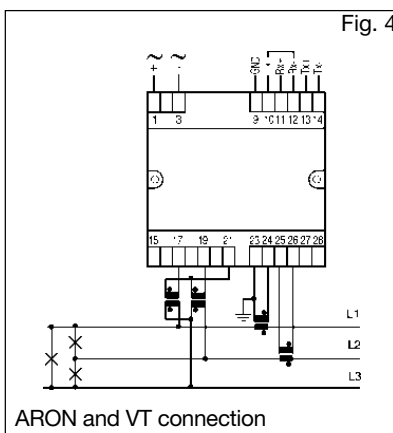
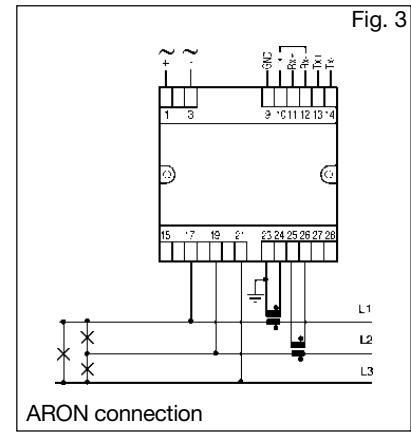
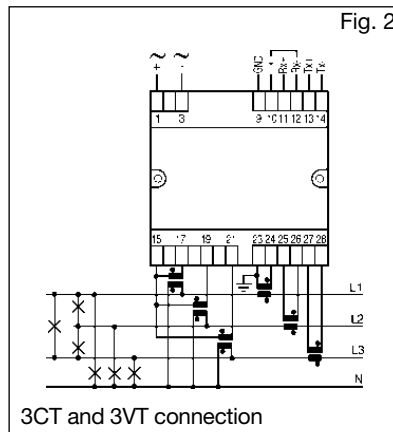
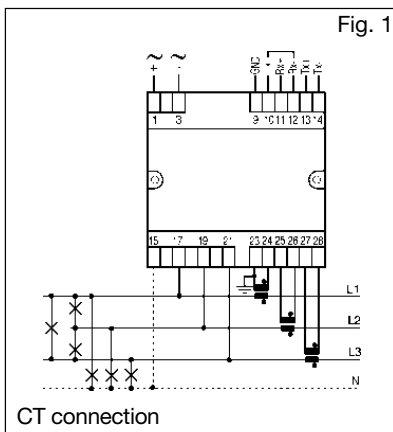

NOTE: the current inputs can be connected to the lines ONLY by means of current transformers. The direct connection is not allowed.

Front Panel Description

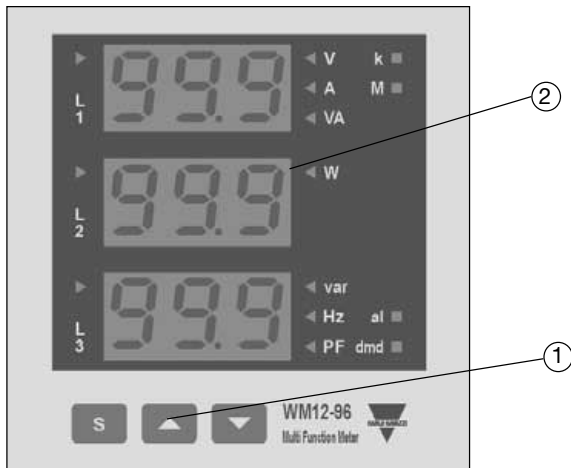

1. Key-pad

To program the configuration parameters and the display of the variables.

S

Key to enter programming and confirm selections;

▲ ▼

Keys to:

- programme values;
- select functions;
- display measuring pages.

2. Display

LED-type with alphanumeric indications to:

- display configuration parameters;
- display all the measured variables.

Dimensions and Panel Cut-out

