

PQA 700 - Power Quality Analyser



User Guide

Manuale Istruzioni

Manual del Usuario

Mode d'emploi

Bedienungsanleitung

Eng

Ita

Esp

Fra

Deu

This manual can not be reproduced, neither partially nor entirely,
without previous authorization from the manufacturer.
The manufacturer declines all liability for any damage to people or
property caused by incorrect use of the product.
Subject to change without prior notice.

TABLE OF CONTENTS

1	SAFETY INFORMATION	4
1.1	TECHNICAL FEATURES	5
2	INSTALLATION	8
2.1	PRELIMINARY OPERATIONS	8
2.2	SAFETY INSTRUCTIONS	8
2.3	CONNECTIONS	9
2.4	CONNECTION DIAGRAMS	10
3	RS232 SERIAL PORT	11
4	USE	12
4.1	MAIN MENU	12
4.2	FUNCTION OF THE KEYS	13
4.3	INSTANT VALUES - MEASUREMENTS	14
4.4	ENERGY COUNTERS AND TIME PERIODS	19
4.5	OSCILLOSCOPE	20
4.6	HARMONIC ANALYSIS	21
4.7	RECORDS	22
4.8	CLOCK	23
4.9	INFO	24
4.10	PRINTING	25
5	PROGRAMMING	30
5.1	KEYS	30
5.2	PROGRAMMING MENU	31
5.3	MAIN PARAMETERS	32
5.4	PRINT	35
5.5	MEMORY	37
5.6	CLOCK / CALENDAR	44
5.7	HOURS AND TARIFFS	45
6	PqaSoft	47
6.1	INTRODUCTION	47
6.2	DISPLAY MENU	49
6.3	SETTING MENU	59
6.4	INSTRUMENT MENU	72

1 SAFETY INFORMATION

This instrument has been manufactured and checked according to safety standards IEC 1010-1, EN61010-1 for measurement electronic instruments, and it is supplied in good conditions.

This manual of use contains all information and warnings to follow in order to ensure good safety conditions for the operator and the instrument itself.

This instrument should be used indoors. In special events, it can operate in temperature conditions between 0°C and -10° without the prejudice of the safety.



Read thoroughly the manual and follow carefully the instructions.

Only trained personnel who understand the risks related to electrocution and who acknowledge the safety standards should use the instrument .

Voltage higher than 50V can be dangerous.

The instrument should be connected to a power supply and measuring circuit equipped with a main switch or a similar device able to disconnect the power supply.

Before supplying power to the instrument, ensure it is adequate to the power supply and measuring circuit voltage.

Before performing the measurement, check that the connections are integral and ensure you have selected the correct measurement.

Opening the instrument (when powered) can be dangerous because of the parts under voltage. Before carrying out any replacement, calibration or repairs inside it, disconnect the instrument from the test circuit. Ensure that only the fuses with the correct rated current and of the established type are used for replacement.

It is forbidden to use the last resource fuses and to short-circuit the fuse-holder.

Do not use the instrument in hazardous safety conditions.

The safety is no more guaranteed:

- * when the instrument is damaged;
- * when the instrument doesn't work;
- * after a long storage in unfavourable conditions;
- * after critical conditions of handling.

The environment of use of the instruments corresponds to pollution level 2 and to installation class (over-voltage class) III/600V according to European standard EN 61010-1. This corresponds to the use of the instrument in an environment with non-conductive pollution (for example, dust); anyway, occasionally, a temporary conductivity due to condensate can occur.

1.1 TECHNICAL FEATURES

AUXILIARY POWER SUPPLY

230 VAC \pm 15% (115VAC \pm 15% on request)

Internal supply battery:	duration 1h without printing and back-lighting.
Consumption with charged battery:	10VA max.
Consumption during battery charge:	25VA max.
Consumption while printing:	30 VA max.
Internal fuse:	1A, 250V, T->1kA, 5x20

MEASUREMENT ACCORDING TO EN50160

Harmonics.
Voltage dips.
Slow and fast changes in power supply.
Interruptions of power supply.

DISPLAY

Type of display:	graphic LCD 240 x 64 dots, back-lighted by LED.
Back-light life:	more than 100.000 hours.
Display refreshing time:	500ms.
Red led:	ON - charging batterie. OFF - charged batterie.

ACCURACY OF THE INSTRUMENT

Voltage:	0.5% reading \pm 0.15% full-scale, 45 to 65 Hz.
Current:	0.5% reading \pm 0.15% full-scale, 45 to 65 Hz.
Frequency:	0.05% reading, 45 at 65Hz.
Active and apparent power	0,8% reading \pm 0,15% full-scale.
TPF:	2% (from 5% to 120% of the measurement; for measurement from 0.5 inductive to 0.8 capacitive).

SAMPLING

Frequency:	6400Hz @ 50Hz.
Resolution:	20ms. for instant values. 10ms. for voltage faults.

MEASUREMENT INPUTS

Voltmetric	N.4 not insulated, separated by protective impedance; max. 700VAC RMS L-L. Maximum peak: 1600V per 1s.
Amperometric	N.3 (non insulated). Max. 1.4 VAC equal to 1400A.

TYPE OF CONNECTION

Single-phase, tri-phase 3-wires, tri-phase 4-wires.

MEASUREMENT METHOD

Type TRMS, peak factor >3 on the current.

MEASUREMENTS CARRIED OUT

Instant variables (line/system):	W, VA, var, V, A, TPF, DPF, Hz.
Maximum demand calculation:	W, VA, A (system var.), calculation interval: to be set 1 to 60 minutes.
Power factor correction capacitor calculation: Fresnel's diagram.	(kvar) necessary to compensate PF.
Minimum and maximum (line/system):	W, VA var, V, A, DPF, TPF, Hz, THD, THD even, THD odd (THD of current and voltage). + Wh, -Wh, + varh, - varh.
Energies: FFT analysis (harmonic distortion):	histogram with indication up to the 50 th harmonic, with absolute and percentage indication of the harmonic content of current and voltage. This analysis is carried out on current values higher than 5% of the set full scale and on voltage values higher than 2% of the full scale.
THD:	in compliance with EN61000-4-7.

RECORDS

Type:	FIFO or Stack.
Record start:	to be set 00:00 to 23:59.
Interval of data integration (min/avg/max):	to be set 1 to 999s.
Type of data recorded:	voltage faults, minimum, average and maximum.
Sampling of data:	voltage faults: 10ms. minimum, average and maximum: 20ms.
Record reference:	date and hour.
Available memory:	512kByte or 1MByte on request.

OSCILLOSCOPE FUNCTION

Current and voltage (current and voltage of a single phase displayed on the same page) with automatic trigger.

SERIAL PORT

RS232 insulated, connector 9 poles female.
Baud rate to be set up to 38400.

PRINTER

Matrix of dots with impact on common paper (width 54 mm)
Columns = 42
Dots per line = 252
Dots per inch = 0.19 x 0.37 mm
Printing speed = 1.0 line /s.
Paper progress speed = 3 mm/s.

PAPER

Width = 57 mm (58 max.)
Thickness = 65 to 85 μ m
Grams = 52 to 64 g/m²
Internal roll-holder center = \varnothing 12 mm min.
External roll diameter = \varnothing 50 mm max. (21m approx.)

TAPE:

Standard: EPSON type ERC09 - Colour: black.

Duration: 250.000 digits with the supplied type, in normal conditions.

The duration depends on the environmental conditions of storage.

ELECTRIC SAFETY

EN61010-1, CAT III, 600Vrms, double insulator

EMC

EN61000-4-2 electrostatic disturbances:

8kV in the air - level 3

4kV in contact - level 2

EN61000-4-3 irradiated electromagnetic field:

10 V/m - level 3 (discontinuous functioning, method B - EN61326-1:1998-04 Tab.2)

EN61000-4-4 quick transients:

2kV - level 3

EN61000-4-5 surge:

2kV

Conducted/radiated Emissions according to EN 50011 class A

OPERATING TEMPERATURE

0°C to +55 °C (R.H. < 90% without condensate).

STORAGE TEMPERATURE

-10° to 60°C (R.H. < 90% without condensate).

OPERATING HUMIDITY

Maximum 75% at 30°C without condensate.

SIZES AND WEIGHT

Case sizes: 160 x 340 x 510 mm.

Weight: 3.2kg (8.2kg complete set)

STANDARD ACCESSORIES

No.3 amperometric clamps max.1220A

No.4 voltage measuring cables

No.1 RS232 serial port cable

No.1 adapter 9-25 poles

No.1 power supply cable

No.1 PqaSoft software

No.1 user guide

2 INSTALLATION

2.1 PRELIMINARY OPERATIONS

Ensure that the instrument has not been damaged during handling. In case of damages, return it to the seller, or you will lose the rights arising from the guarantee.

We suggest you should keep the original packaging in case of further shipping of the instrument.

Check the content of the packaging box:

- * 1 handling bag
- * 1 instrument-holder belt
- * 1 user guide
- * 3 amperometric clamps
- * 4 voltage measuring cables
- * 1 RS232 serial port connecting cable equipped with adapter 9/25 poles
- * 1 power supply cable
- * 1 software PqaSoft

2.2 SAFETY INSTRUCTIONS



Before carrying out all connections, ensure that the wires are not under voltage.



Connect the instrument according to the connection diagram (see capt. 2.4.1).



The instrument can be powered by means of the internal rechargeable battery. To recharge the battery, connect the instrument by means of the special connection wire to the mains voltage 230 VAC. The battery can be fully charged in approximately 5 hours.



If the instrument does not switch on, the internal protection fuse can be the cause. Contact the Assistance Service to replace it.

2.3 CONNECTIONS



The instrument carries out bi-directional measurements. In order to achieve correct measurements, it's very important to connect the instruments respecting the polarity.

For instance, if you connect a current input and you obtain a measurement with a sign opposite in comparison to the expected one, turn the direction of the clamps.



Follow the connection diagrams and respect the cyclic order of the phases (important: L1 of the voltmetric input = L1 of the amperometric input).



In case of use of VT (Voltmetric Transformers), pay attention to respect the input and output poles.

For instance, if you connect the phase L1 to the "U" terminal and the neutral to the "V" terminal of the VT primary, connect the "u" terminal of the VT secondary to the L1 terminal of the instrument and the "v" terminal of VT to the neutral of the instrument.

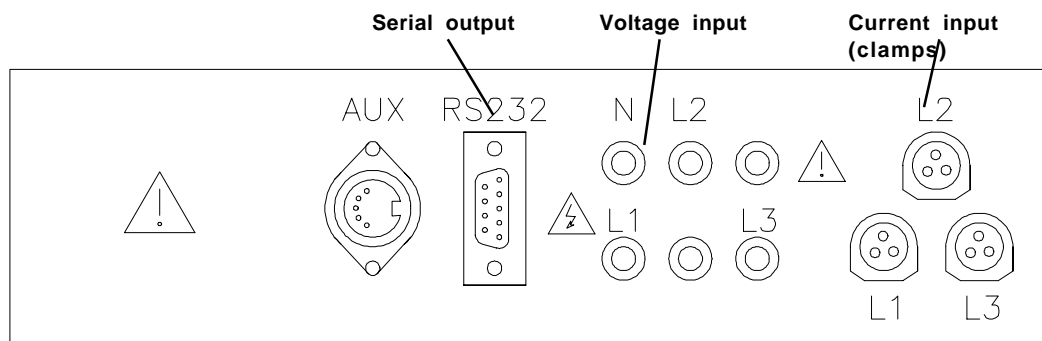

Pict. 2.3.1 - Measuring and communication input/output

2.4 CONNECTION DIAGRAMS

Select the corresponding diagram on the instrument from the programming menu

2.4.1 3 phases - 4 wires/3 clamps

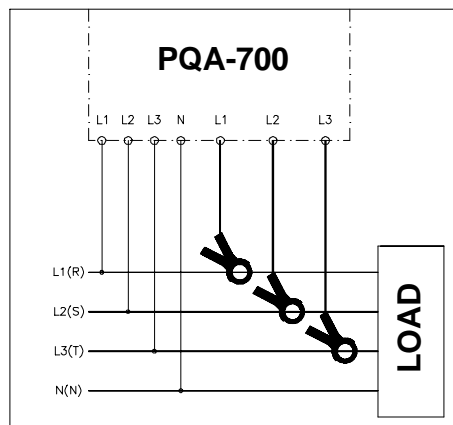

Measuring voltage by direct connection

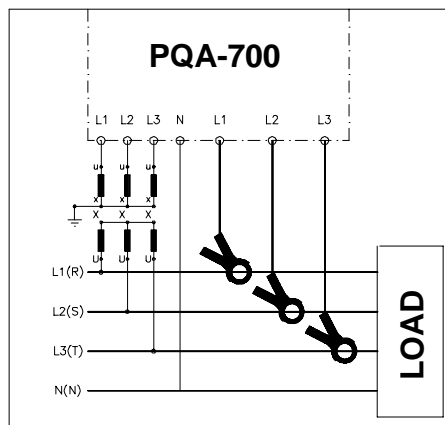

Measuring voltage by voltage transformer

2.4.2 3 phases - 3 wires/2 clamps

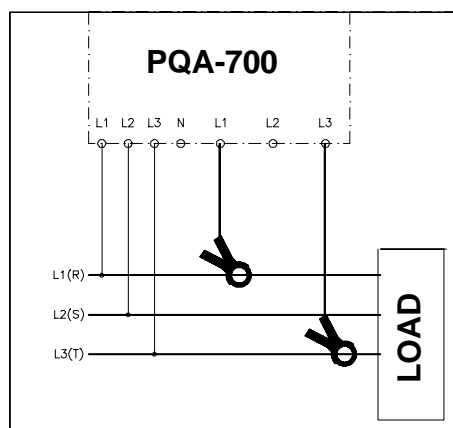

Measuring voltage by direct connection

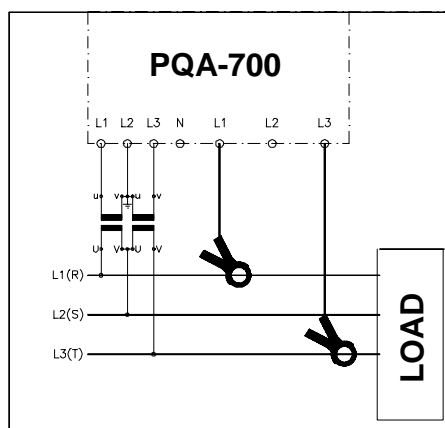

Measuring voltage by voltage transformer

When you select a 3-wire system (without neutral), the phase values are not indicated, as they could be incorrect. These values, as a matter of fact, are referred to a virtual neutral generated inside the instrument.

2.4.3 Single-phase

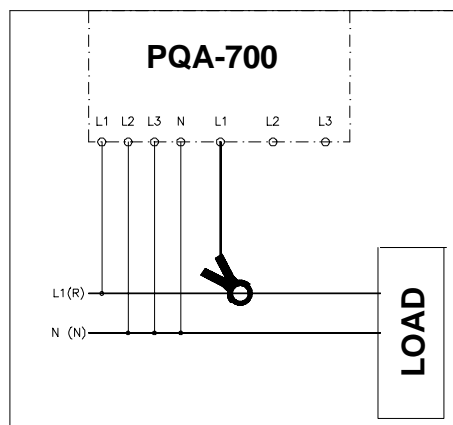

3 RS232 SERIAL PORT

Communication with the instrument occurs by means of RS232 asynchronous serial transmission. All transmitted digits are part of the ASCII code.

The standard RS232 interface allows the connection between only one instrument and the PC.

Using your own SERIAL NUMBER you can examine the instrument.

Use a standard RS232 shielded wire with 2 connectors DB 9 poles and, if necessary, a 25/9 adapter for the connection.

Before using different wires, ask the Technical Department.

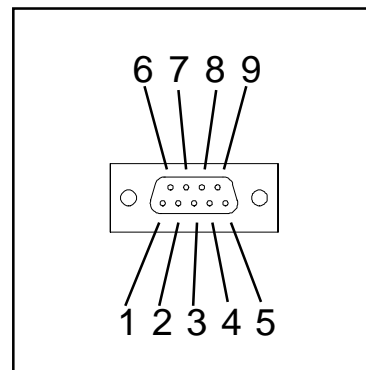

Pict. 3.1 - Connector RS232

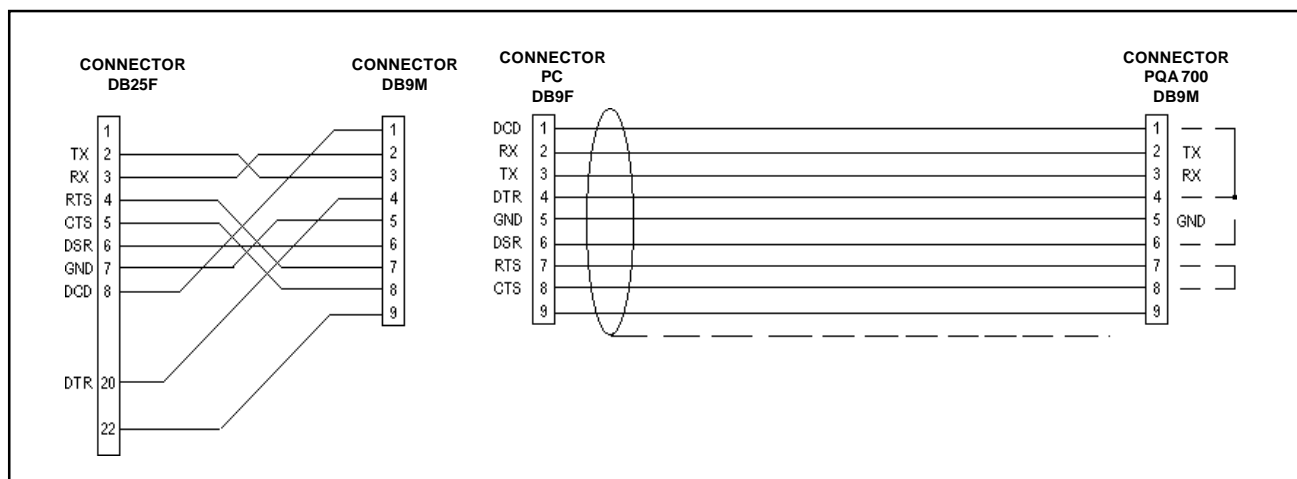

Pict. 3.2 - RS232 connecting wire



4 USE

4.1 MAIN MENU

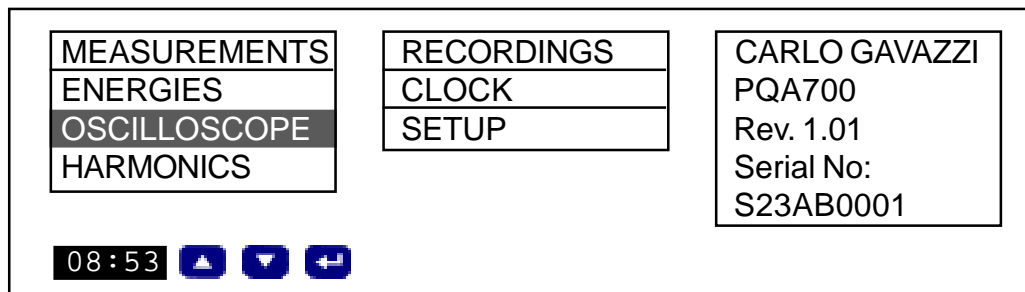
When the instrument is switched on, the page in Pict. 4.1.1 is displayed.





Pict. 4.1.1 - Menu page

Select the desired function by means of keys  and  and confirm with .



Note:

The number and format of pages displayed by the instrument depend on the type of connection selected.

4.2 FUNCTION OF THE KEYS

  - (UP, DOWN)

When pressed individually, the page changes and the selecting cursor moves to the possible selections.

  - (LEFT, RIGHT)

When pressed individually, the selecting cursor moves to the possible selections.

 - (CONFIRM YOUR SELECTION)

It confirms the selection and displays the selected function.

 - (ESCAPE THE MENU)

It exits the programming page and goes back to the main menu.

 - (DISPLAY PRINT PAGE)

It prints the displayed page (PRINTSCREEN).

 - (PRINT MENU)

It enters the print menu (s.chap. 4.10).

 - (PAPER FEED)

It makes the paper progress.

 - (INFORMATION)



By pressing it on display pages (except for programming and menu) the information page is displayed (see chap.4.9).

 - (BACK-LIGHTENING)

When the display back-lightening is off, it switches it on for the set time.

Warning: To obtain a longer battery-fed functioning of the instrument it is suggested not to activate back lightening.

 - (CONTRAST)

It displays the bar for display contrast adjustment; adjust from 0 to 100% pressing the keys   , then confirm with  . After 5 seconds without adjustments of the contrast, the adjusting bar disappears.

 - (MAIN MENU)

The main menu is displayed.

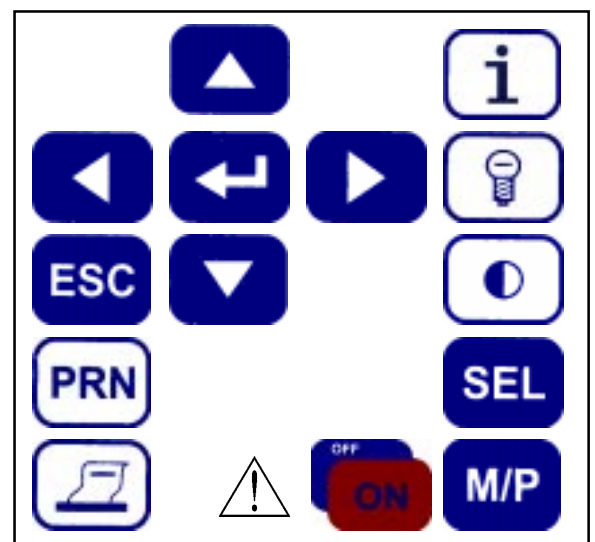

Pict. 4.2.1 - PQA700 Keyboard

4.3 INSTANT VALUES - MEASUREMENTS

The pages show the instant measurements carried out by the instrument.



4.3.1 SYMBOLS

L, C On the left side of the $\cos \phi$ /DPF, Reactive Power and Reactive Energy values, L is displayed if the charge is inductive or C if the charge is capacitive.



- + Transfer and consumption of energy are indicated respectively by minus (-) and plus (+) near the Current, Active Power and Apparent Power values.

The different possible combinations depend on the type of connection used in the measurements.



Connection diagram 3Phases-4Wires/3Clamp:

Σ	380.7 V	+1.150 kVA
	+0003 A	L0.051 kvar
	+1.122 kW	+0.828 kWdmd
		L0.910 TPF
		50.01 Hz
08:53  		



Pict. 4.3.1 - Main system variables: voltage, current, active power, apparent power, reactive power, average power, power and frequency factors

L₁	220.7 V	L₁₋₂	380.5 V
L₂	220.2 V	L₂₋₃	381.2 V
L₃	220.3 V	L₃₋₁	380.9 V
08:53  			

Pict. 4.3.2 - Neutral-phase and phase-phase voltages

L₁	+0.374 kW	L₁	L0.051 kvar
L₂	+0.374 kW	L₂	L0.051 kvar
L₃	+0.374 kW	L₃	L0.051 kvar
08:53  			

Pict. 4.3.3 - Active and reactive phase power

L₁	+0.383 kVA	L₁	+2.843 A
L₂	+0.383 kVA	L₂	+2.850 A
L₃	+0.385 kVA	L₃	+2.845 A
08:53  			

Pict. 4.3.4 - Apparent power and instant phase current

L_1	007.4	V-thd%	L_1	009.2	A-thd%
L_2	007.4	V-thd%	L_2	009.2	A-thd%
L_3	007.4	V-thd%	L_3	009.2	A-thd%

08:53

Pict. 4.3.5 - Total harmonic distortion as a % of voltage and current

+0015	A	+1.658	kAdmd
+1.122	kW	+1.122	kWdmd
+1.150	kVA	+1.150	kVAdmd

08:53

Pict. 4.3.6 - System variables: current, active power, Apparent power and respective average values measured

	V	A	kW	TPF
L1	220.3	+0015	+0.374	L0.910
L2	220.3	+0015	+0.374	L0.910
L3	220.3	+0015	+0.374	L0.910
ΣL	220.3	+0015	+1.122	L0.910

08:53

Pict. 4.3.7 - Voltages, currents, active power and instant phase and system TPF

	kVA	kvar	V-thd%	A-thd%
L1	+0.383	L0.017	007.4	009.2
L2	+0.383	L0.017	007.4	009.2
L3	+0.383	L0.017	007.4	009.2
ΣL	+1.150	L0.051		

08:53

Pict. 4.3.8 - Apparent power, reactive power, percentage of distortion of instantaneous voltage and current of phase and system.

L_1	L0.910	TPF
L_2	L0.910	TPF
L_3	L0.910	TPF

08:53

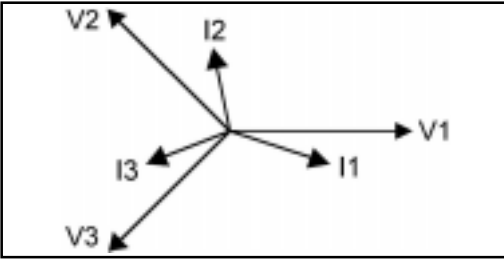

Pict. 4.3.9 - TPF - power factor: numeric values and Fresnel's diagram.

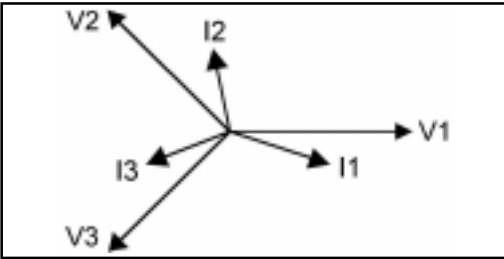

L_1	L0.857	DPF
L_2	L0.857	DPF
L_3	L0.857	DPF

08:53





Pict. 4.3.10 - DPF - $\cos \phi$: numeric values and Fresnel's diagram.



Connection diagram 3Phases-3Wires/2Clamps:

Σ	380.7 V	+1.150 kVA
	+0015 A	L0.051 kvar
	+1.122 kW	+0.828 kWdmd
		L0.910 TPF
		50.01 Hz
08:53  		



Pict. 4.3.11 - Main system variables: voltage, current, active power, apparent power, reactive power, average power, power factor and frequency

Σ	+0015 A	+1.658 kAdmd
	+1.122 kW	+1.122 kWdmd
	+1.150 kVA	+1.150 kVAdmd
08:53  		

Pict. 4.3.12 - System variables: current, active power, apparent power and respective average values measured

L₁₋₂	380.5 V	L₁	+2.843 A
L₂₋₃	381.2 V	L₂	+2.850 A
L₃₋₁	380.9 V	L₃	+2.845 A
08:53  			



Pict. 4.3.13 - Neutral-phase voltage and line currents

L₁	009.2 A-thd%
L₃	009.2 A-thd%
08:53  	

Pict. 4.3.14 - Total harmonic distortion as a % of current



Single phase connection diagram:

380.7 V	+1.150 kVA
+0015 A	L0.051 kvar
+1.122 kW	+0.828 kWdmd
	L0.910 TPF
	50.01 Hz

08:53  



Pict. 4.3.15 - Main system variables: voltage, current, active power, apparent power, reactive power, average power, power factor and frequency

+0015 A	+1.658 kAdmd
+1.122 kW	+1.122 kWdmd
+1.150 kVA	+1.150 kVAdmd

08:53  

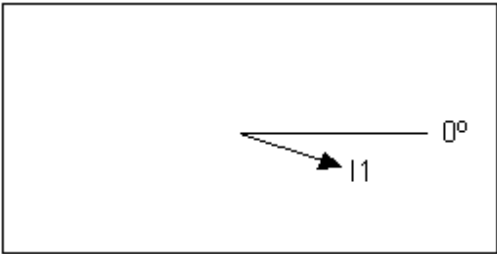

Pict. 4.3.16 - System variables: current, active power, apparent power and respective average values measured

L0.910 TPF	
-------------------	---

08:53  

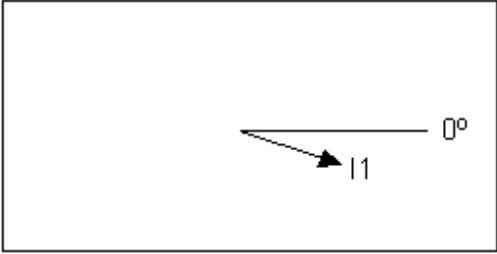
Pict. 4.3.17 - True Power Factor of phase and Fresnel's diagram



L0.857 DPF	
007.4 V-thd%	
009.2 A-thd%	

08:53  

Pict. 4.3.18 - Displacement Power Factor (cos φ), total harmonic distortion as a % of voltage and current, Fresnel's diagram





4.3.2 POWER FACTOR CORRECTION

It calculates the power of the DPF- correction capacitor(var), necessary to increase the measured value to the desired one (Target).

By means of the keys   select a value among the available ones (1.000, 0.990, 0.980, 0.970, 0.960, 0.950, 0.940, 0.930, 0.920, 0.910, 0.900, 0.850, 0.800).





The calculation of the power factor correction capacitors is only possible by selecting the 3Phases-4Wires / 3Clamps or Single-phase connection diagram.

Connection diagram: 3phases-4wires/3clamps

Target :		DPF	var
0.910	L1	0.848	0016.2kvar
	L2	0.850	0015.6kvar
	L3	0.852	0015.3kvar
08:53    			

Pict. 4.3.19 - Calculation of the DPF (cos ϕ) power factor correction capacitor

Connection diagram: Single-phase

Target :		DPF	var
0.910	L1	0.848	0016.2kvar
08:53    			

Pict. 4.3.20 - Calculation of the DPF (cos ϕ) correction capacitor



4.4 ENERGY COUNTERS AND TIME PERIODS

These pages show the energy meters and counters divided into time periods.



If the automatic printing of counters divided into time periods is activated (see this manual, sect. 5), at 24:00 the instrument automatically prints the said values before the reset.

4.4.1 SYMBOLS

L, C On the left side of the Reactive Energy values, L is displayed if the charge is inductive or C if the charge is capacitive.







Σ	CONSUMPTION	GENERATION
	00000513 kWh	00000513 kWh
	00001025 kVAh	00001025 kVAh
	L00000071 kvarh	L00000071 kvarh
	C00000012 kvarh	C00000012 kvarh
08:53  		

Pict. 4.4.1 - Energy meters

T1	CONSUMPTION	GENERATION
	00000513 kWh	00000513 kWh
	00001025 kVAh	00001025 kVAh
	L00000071 kvarh	L00000071 kvarh
	C00000012 kvarh	C00000012 kvarh
08:53  		



Pict. 4.4.2 - Energy counters divided into hours. This page is the same for phase 2 and 3.

To reset manually all the counters, press ; the following message is displayed "Clear?"; select "YES/NO" by the key  ; confirm the choice with .

T1	CONSUMPTION	GENERATION
	00000513 kWh	00000513 kWh
	00001025 kVAh	00001025 kVAh
	L00000071 kvarh	L00000071 kvarh
	C00000012 kvarh	C00000012 kvarh
08:53   Clear?  YES   		

4.5 OSCILLOSCOPE

These pages show the graphic form of the current and voltage waves of each phase.

Press the keys  and  to change the displayed phase (L1 - L2 - L3).

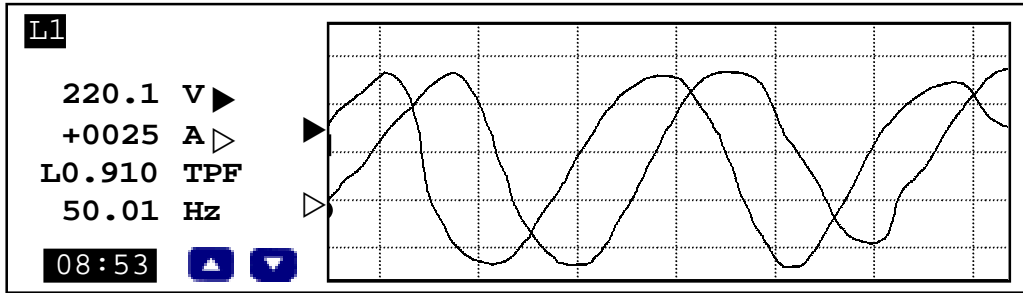

Pict. 4.5.1 - Oscilloscope pages. This page is the same for phase 2 and 3

In case of 3 Phases - 3Wires / 2Clamps connection, only 2 pages are displayed (L1 and L3) and only the current wave is shown.

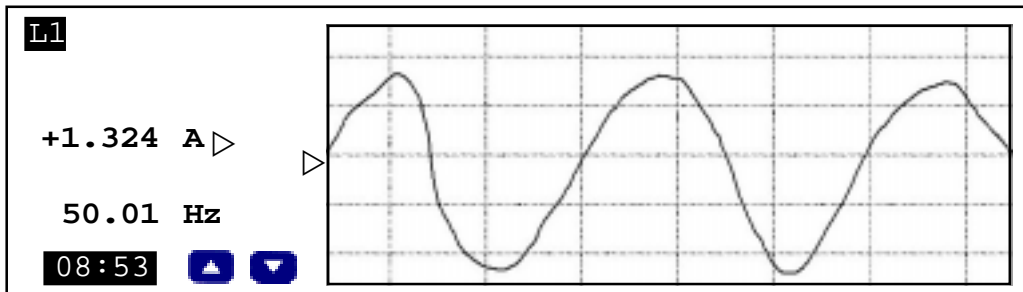

Pict. 4.5.1 - Oscilloscope pages. This page is the same for phase 3.

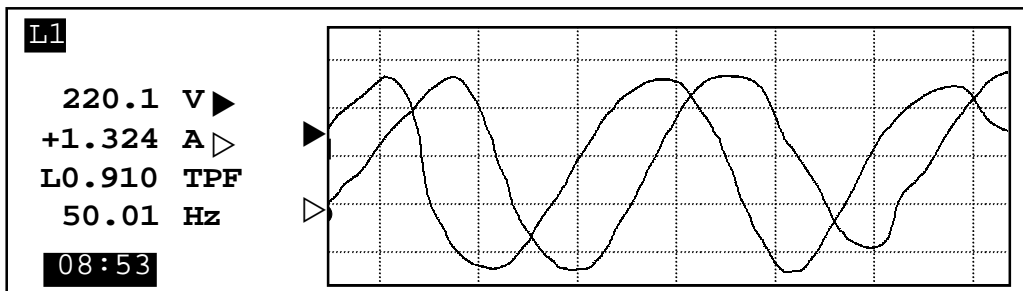

In case of Single-Phase connection, the displayed page shows only the current and voltage wave.





Pict. 4.5.6 - Oscilloscope page

4.6 HARMONIC ANALYSIS

For each phase, the pages show the harmonic content of the measured current and voltage. The percentage and absolute values displayed, refer to the selected harmonic.

Press the keys  and  to change the displayed variable (V1, A1, V2, A2, V3, A3).

Press the keys  and  to change the harmonic, for which the numeric values are displayed (1-50).

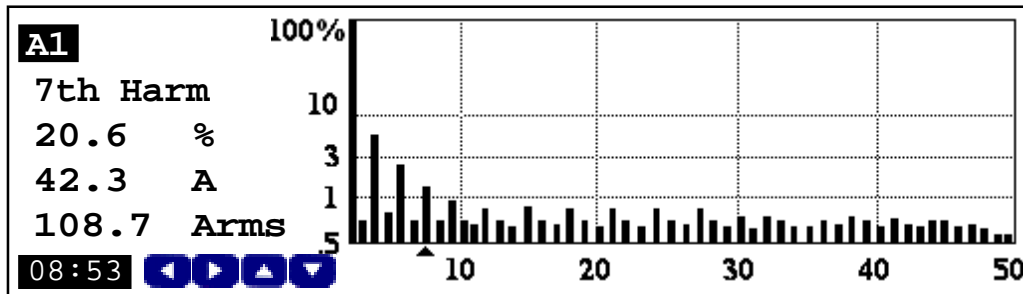

Pict. 4.6.1 - Graphic and numeric pages of the current harmonics.

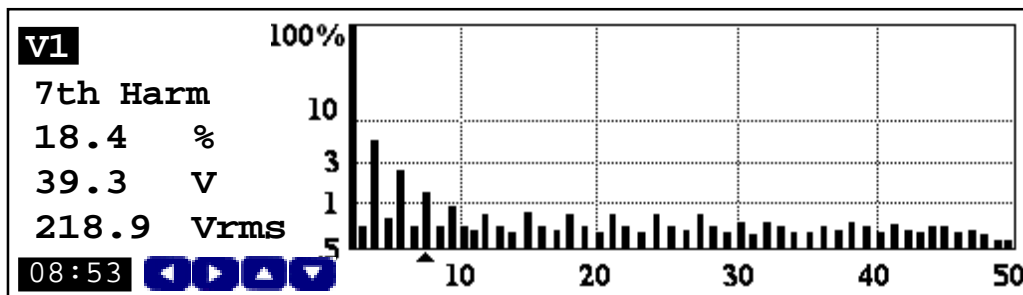

Pict. 4.6.2 - Graphic and numeric pages of the voltage harmonics.

In case of 3Phases-3Wires/2Clamps connection, only the two pages related to the measured current on phase 1 and 3 are displayed (A1 and A3).

In case of Single-Phase connection, only the two pages related to current and voltage are displayed.

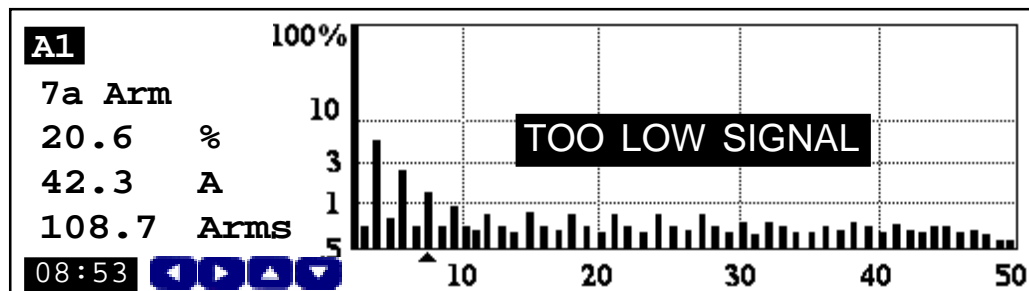

Pict. 4.6.3 - Display message too low signal for carrying out harmonic analysis

When the current signals are lower than 5% of the set full scale and the voltage signals are lower than 2% of the set full scale, the harmonic analysis is not carried out; the instrument displays the message "Too low signal".

4.7 RECORDS

The displayed page shows the information about the programmed record.

The instrument allows two types of records: "Voltage dips" and "MIN/AVG/MAX"; The two types of record can not be selected at the same time.

When no record is selected, the page displays the following message:

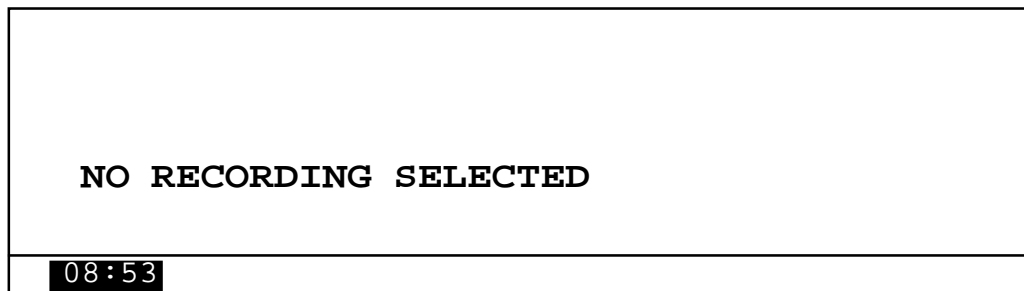

Pict. 4.7.1 -
No record

When the Voltage dips recording is programmed, the following page is displayed:

V1	Voltage dips	EV.	TOTAL	MEMO
Integr.t:	00 m. FIX	V1:	0012	0012
Vn.	220V	V2:	0003	0003
Hset.	231.0V	V3:	0007	0007
Lset.	198.0V	RAM:	0000.02 kB	

08:53

Pict. 4.7.2 -
Voltage dips recording

The page shows the programming parameters of the record: integration time for the automatic calculation of the reference value, set reference value and high and low set-point values; furthermore, it shows the total amount of events detected by the instrument since the beginning of recording, the amount of recorded events and the quantity of occupied RAM.

When the RAM is full, the instrument will over-write the new entries on the oldest values.

IMPORTANT: always select the 3Phases-4Wires/3Clamps connection diagram to record the Voltage dips.

When the MIN/AVG/MAX recording is selected, the following page is displayed:

MIN/AVG/MAX	
Integr.t:	010 sec Rec. type: FIFO
Status:	ON
Var.	V1-V2-V3-A1-A2-A3-kW-kW1-kW2-kW3

08:53

Pict. 4.7.3 -
MIN/AVG/MAX recording

This page shows the programming parameter of recording: integration time, selected variables and recording type.

Furthermore, the page shows the recording status ("ON"=activated, "OFF"=deactivated, "WAIT"=waiting for the programmed delay time - s.sect.5.5.2).

See section 5.5.2 of this manual for further information related to the correct programming of recording.

To display the values saved by the instrument, it's necessary to transfer them in advance to the PC.

4.8 CLOCK

This page shows the set date and time of the instrument.

The American or European format can be selected from the programming pages of the instrument.

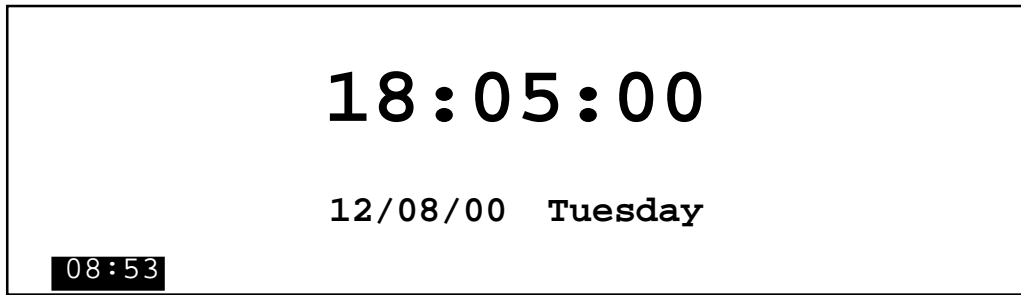

Pict. 4.8.1 -
Date/time (European format)

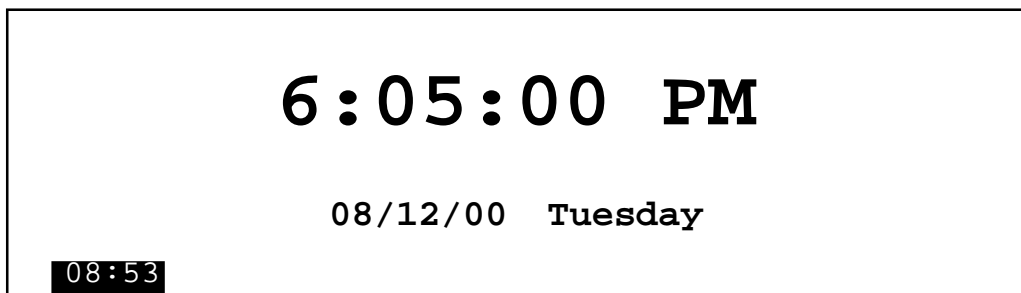

Pict. 4.8.2 -
Date/time (American format)

4.9 INFO

To enter the Info page, press the  key.

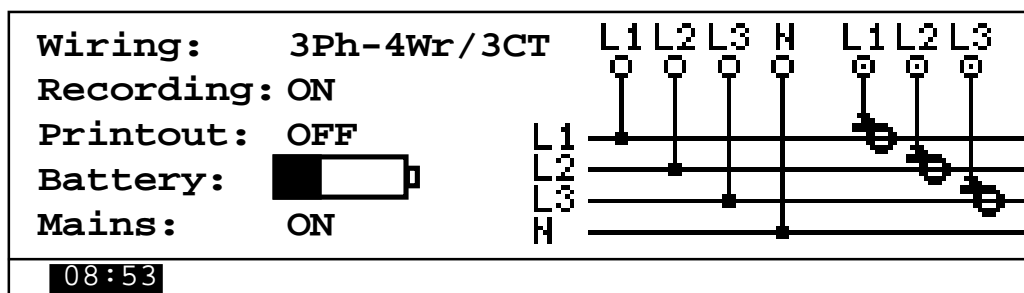

Pict. 4.9.1 - Info page

The page shows some general information related to the instrument, such as:

- the selected wiring diagram;
- the recording status; for further information on the on-going storings enter the proper page;
- the automatic printing status;
- the battery status;
 - fixed indicator: the battery has a certain level of storage⁽¹⁾;
 - moving indicator: battery under charge⁽²⁾;
 - interrupted indicator: endamaged battery, contact the technical service for replacement;
- the wiring mode of the instrument to the mains.

Note⁽¹⁾: the picture is only an indication.

Note⁽²⁾: the battery charges automatically when the instrument is switched on and connected to the mains. To charge the battery after a period of inactivity, connect the instrument to the mains network, switch it on for a few seconds and then switch it off: the charging will go on automatically. At the end of the charging the LED on the cover of the display switches off.

To exit the Info page and go back to the previously displayed page, press the key .

Warning: when the battery charge is exhausted, in anyone of the displayed pages, the icon of exhausted battery replaces the time alternatively.

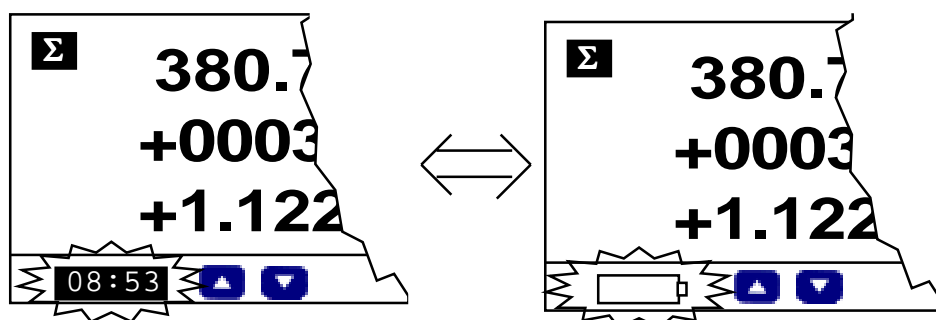

Pict. 4.9.2 - Exhausted battery icon



4.10 PRINTING

Press the key  on the display pages (except programming pages and menu) to enter the manual printing menu.

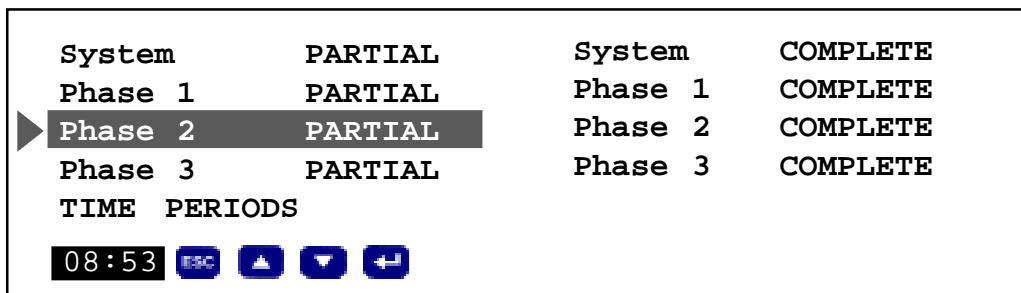
Warning: if you press this key for more than 3 seconds, the current displayed page will be printed.



Pict. 4.10.1 -
Printing menu page

By means of keys  and  select the desired printing and confirm with .

To exit the printing menu without printing, press the key .

- "PARTIAL" System

Partial printing of the values measured by the instrument (see example 4.10.1).

- "COMPLETE" System

Complete printing of all the values measured by the instrument (see example 4.10.2).

- "PARTIAL" PHASE n

Partial printing of the values measured by the instrument related to the selected phase (see example 4.10.3).

In case of 3 phases - 3 wires / 2 clamps connection, only Phase 1 and 3 are indicated.

In case of single-phase connection, only Phase 1 is indicated.

- "COMPLETE" PHASE n

Complete printing of the values measured by the instrument related to the selected phase (see example 4.10.4).

In case of 3 phases - 3 wires / 2 clamps connection, only Phase 1 and 3 are indicated.

In case of single-phase connection, only Phase 1 is indicated.

- TIME PERIODS

Manual printing of consumptions, divided into time periods, related to the current day (see example 4.10.5).

4.10.1 EXAMPLES OF MANUAL PRINTING

CONNECTION: 3 phases - 4 wires / 3 clamps

Measurements			
Wiring:		3Ph-4W./3CT	
Date 05/09/00		Time 08:29	

V:	380.4	A:	137.2
kVA:	90.39	kW:	80.54
kvar:	41.23	Aavg:	126.8
kVAdmd:	89.22	kWdmd:	79.74
TPF:	0.891	Hz:	050.1
+kWh:	00000000	-kWh:	00000000
+kVAh:	00000000	-kVAh:	00000000
+kvarhl:	00000000	-kvarhl:	00000000
+kvarhc:	00000000	-kvarhc:	00000000

Example 4.10.1 - partial printing of measurement

Measurements			
Wiring:		3Ph-4W./3CT	
Date 05/09/00		Time 08:29	

V:	380.2	A:	137.2
kVA:	90.35	kW:	80.50
kvar:	41.23	Aavg:	126.8
kVAdmd:	89.22	kWdmd:	79.74
TPF:	0.891	Hz:	050.1
+kWh:	00005072	-kWh:	00000000
+kVAh:	00005903	-kVAh:	00000000
+kvarhl:	00002376	-kvarhl:	00000000
+kvarhc:	00000000	-kvarhc:	00000000

V1:	219.6	V12:	381.4
V2:	220.1	V23:	378.8
V3:	218.9	V31:	380.5
A1:	136.9	kVA1:	30.06
A2:	138.5	kVA2:	30.48
A3:	136.4	kVA3:	29.86
kW1:	27.03	kvar1:	13.81
kW2:	27.04	kvar2:	13.79
kW3:	27.14	kvar3:	13.62
TPF1:	0.899	DPF1:	0.851
TPF2:	0.887	DPF2:	0.843
TPF3:	0.909	DPF3:	0.875
Vthd1%:	003.4	Athd1%:	009.1
Vthd2%:	003.1	Athd2%:	008.7

Example 4.10.2 - complete printing of measurement

Phase 1 Measurements			
Wiring:		3Ph-4W./3CT	
Date 05/09/00		Time 08:29	

V1:	219.6	V12:	381.4
A1:	136.9	kVA1:	30.06
kW1:	27.03	kvar1:	13.81
TPF1:	0.899	DPF1:	0.851
Vthd1%:	003.4	Athd1%:	009.1

Example 4.10.3 - partial printing of measurement of phase 1

Phase 1 Measurements				
Wiring:		3Ph-4W./3CT		
Date 05/09/00		Time 08:29		

V1:	219.6	V12:	381.4	
A1:	136.9	kVA1:	30.06	
kW1:	27.03	kvar1:	13.81	
TPF1:	0.899	DPF1:	0.851	
Vthd1%:	003.4	Athd1%:	009.1	

h	A	A%	V	V%
h01	126.4	100.00	212.9	100.00
h02	000.1	000.09	000.2	000.09
h03	004.9	003.12	009.1	004.28
h04	000.1	000.08	000.2	000.09
h05	002.8	001.24	002.1	001.11
.				
.				
h49	000.0	000.00	000.0	000.00
h50	000.0	000.00	000.0	000.00

Example 4.10.4 - complete printing of measurement of ph. 1

Time periods measurements			
Wiring:		3Ph-4W./3CT	
Date 05/09/00		Time 08:29	

	T1	T2	T3
+kWh:	00000123	00000379	00001013
+kVAh:	00000138	00000401	00001208
+kvarhl:	00000098	00000183	00000397
+kvarhc:	00000000	00000000	00000000

-kWh:	00000000	00000000	00000000
-kVAh:	00000000	00000000	00000000
-kvarhl:	00000000	00000000	00000000
-kvarhc:	00000000	00000000	00000000

Example 4.10.5 - printing of meters divided into hours

CONNECTION: 3 phases - 3 wires / 2 clamps

```

Measurements
Wiring:      3Ph-3W./2CT
Date 05/09/00      Time 08:29
-----
V:          380.4      A:          137.2
kVA:       90.39      kW:         80.54
kvar:      41.23      Aavg:       126.8
kVAdmd:    89.22      kWdmd:     79.74
TPF:       0.891      Hz:        050.1
+kWh:      00000000    -kWh:      00000000
+kVAh:     00000000    -kVAh:     00000000
+kvarhl:   00000000    -kvarhl:   00000000
+kvarhc:   00000000    -kvarhc:   00000000
    
```

Example 4.10.6 - partial printing of measurement

```

Measurements
Wiring:      3Ph-3W./2CT
Date 05/09/00      Time 08:29
-----
V:          380.4      A:          137.2
kVA:       90.39      kW:         80.54
kvar:      41.23      Aavg:       126.8
kVAdmd:    89.22      kWdmd:     79.74
TPF:       0.891      Hz:        050.1
+kWh:      00000000    -kWh:      00000000
+kVAh:     00000000    -kVAh:     00000000
+kvarhl:   00000000    -kvarhl:   00000000
+kvarhc:   00000000    -kvarhc:   00000000
-----
V12:       381.4      A1:        136.9
V23:       378.8      A2:        138.5
V31:       380.5      A3:        136.4
Athd1%:    009.1      Athd3%:    008.4
    
```

Example 4.10.7 - complete printing of measurement

```

Phase 1 Measurements
Wiring:      3Ph-3W./2CT
Date 05/09/00      Time 08:29
-----
A1:         136.9      Athd1%:    009.1
    
```

Example 4.10.8 - partial printing of measurement of phase 1

```

Phase 1 Measurements
Wiring:      3Ph-3W./2CT
Date 05/09/00      Time 08:29
-----
A1:         136.9      Athd1%:    009.1
-----
h           A          A%          V          V%
h01        126.4      100.00     ----.-    ----.-
h02         000.1      000.09     ----.-    ----.-
h03         004.9      003.12     ----.-    ----.-
h04         000.1      000.08     ----.-    ----.-
h05         002.8      001.24     ----.-    ----.-
.
.
h49         000.0      000.00     ----.-    ----.-
h50         000.0      000.00     ----.-    ----.-
    
```

Example 4.10.9 - complete printing of measurement of ph. 1

```

Time periods measurements
Wiring:      3Ph-3W./2CT
Date 05/09/00      Time 08:29
-----
                        T1          T2          T3
+kWh:      00000123    00000379    00001013
+kVAh:     00000138    00000401    00001208
+kvarhl:   00000098    00000183    00000397
+kvarhc:   00000000    00000000    00000000
-----
-kWh:      00000000    00000000    00000000
-kVAh:     00000000    00000000    00000000
-kvarhl:   00000000    00000000    00000000
-kvarhc:   00000000    00000000    00000000
    
```

Example 4.10.10 - printing of meters divided into hours

CONNECTION: MONOPHASE

```

Measurement
Wiring: Monophase
Date 05/09/00      Time 08:29
-----
V:      380.4      A:      137.2
kVA:    90.39     kW:     80.54
kvar:   41.23     Aavg:   126.8
kVAdmd: 89.22     kWdmd:  79.74
TPF:    0.891     DPF:    0.854
+kWh:   00000000  -kWh:   00000000
+kVAh:  00000000  -kVAh:  00000000
+kvarhl:00000000  -kvarhl:00000000
+kvarhc:00000000  -kvarhc:00000000
Hz:     050.1
    
```

Example 4.10.11 - partial printing of measurement

```

Measurement
Wiring: Monophase
Date 05/09/00      Time 08:29
-----
V:      380.4      A:      137.2
kVA:    90.39     kW:     80.54
kvar:   41.23     Aavg:   126.8
kVAdmd: 89.22     kWdmd:  79.74
TPF:    0.891     DPF:    0.854
+kWh:   00005072  -kWh:   00000000
+kVAh:  00005903  -kVAh:  00000000
+kvarhl:00002376  -kvarhl:00000000
+kvarhc:00000000  -kvarhc:00000000
Hz:     050.1
-----
Vthd%:  003.4     Athd%:  009.1
    
```

Example 4.10.12 - complete printing of measurement

```

Phase 1 Measurements
Wiring: Monophase
Date 05/09/00      Time 08:29
-----
V1:      219.6
A1:      136.9     kVA1:   30.06
kW1:     27.03     kvar1:  13.81
TPF1:    0.899     DPF1:   0.851
Vthd1%:  003.4     Athd1%: 009.1
    
```

Example 4.10.13 - partial printing of measurement of phase 1

```

Phase 1 Measurements
Wiring: Monophase
Date 05/09/00      Time 08:29
-----
V1:      219.6
A1:      136.9     kVA1:   30.06
kW1:     27.03     kvar1:  13.81
TPF1:    0.899     DPF1:   0.851
Vthd1%:  003.4     Athd1%: 009.1
-----
h         A         A%         V         V%
h01      126.4     100.00     212.9     100.00
h02       000.1     000.09     000.2     000.09
h03       004.9     003.12     009.1     004.28
h04       000.1     000.08     000.2     000.09
h05       002.8     001.24     002.1     001.11
.
.
h49       000.0     000.00     000.0     000.00
h50       000.0     000.00     000.0     000.00
    
```

Example 4.10.14 - complete printing of measurement of ph. 1

```

Time periods measurements
Wiring: Monophase
Date 05/09/00      Time 08:29
-----
                T1         T2         T3
+kWh:           00000123    00000379    00001013
+kVAh:           00000138    00000401    00001208
+kvarhl:         00000098    00000183    00000397
+kvarhc:         00000000    00000000    00000000
-----
-kWh:           00000000    00000000    00000000
-kVAh:           00000000    00000000    00000000
-kvarhl:         00000000    00000000    00000000
-kvarhc:         00000000    00000000    00000000
    
```

Example 4.10.15 - printing of meters divided into hours

4.10.2 EXAMPLES OF AUTOMATIC PRINTING

Automatic printing can be programmed by the user; it is possible to set the variables to be printed, selecting them among the pre-set combinations and defining the printing time interval.

The different combinations depend on the type of connection used for the measurement.

See section 5.4 of this manual for the possible combinations of each connection diagram.

Print interval: 005 min					
Wiring: Monophase					
Date 05/09/00		Time 08:29			

	Vsys	Isys	Psys	Pdmd	Qsys
HH:MM	V	A	kW	kWdmd	kvar
08:30	380.1	857.3	507.9	499.6	246.0
08:35	380.4	857.9	508.7	504.7	245.7
08:40	379.9	857.0	510.1	506.5	246.1
08:45	380.7	858.1	506.7	507.4	247.0
.					
.					
09:50	381.1	856.9	507.8	507.9	244.6
09:55	380.8	857.6	508.3	508.3	245.8

Example 4.10.16 - automatic printing - table

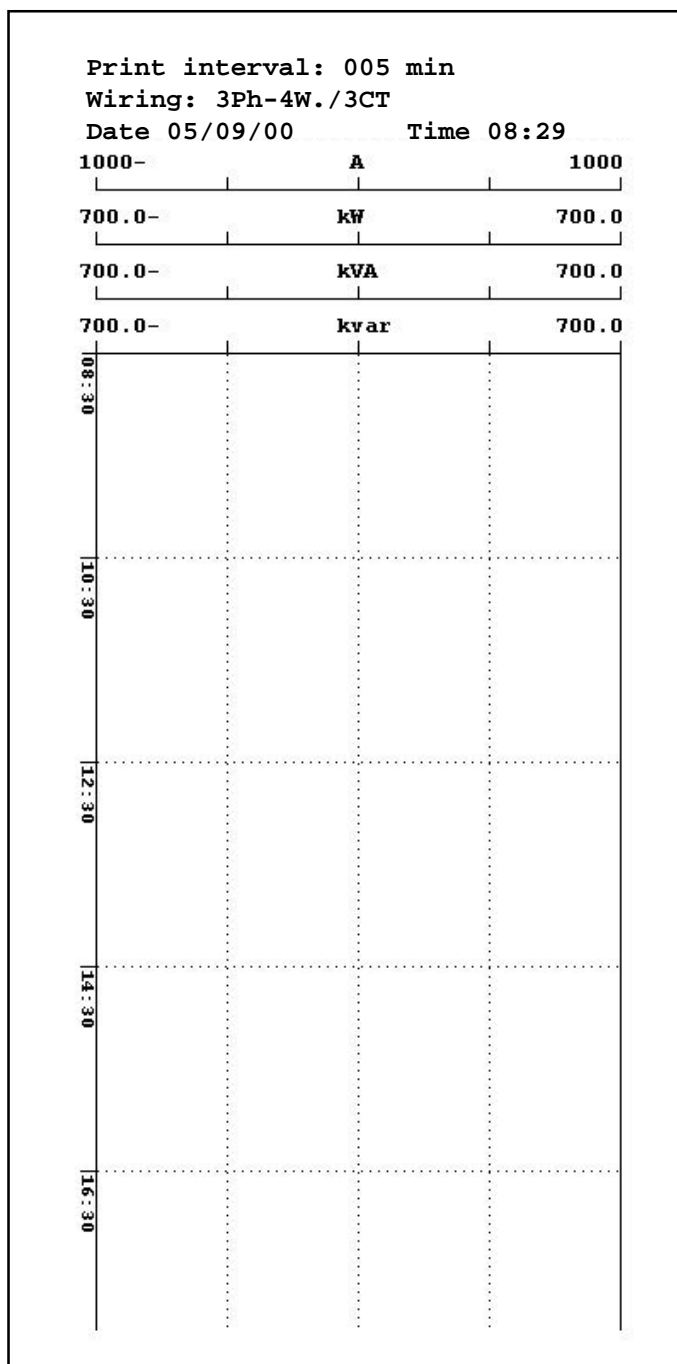

Example 4.10.17 - automatic printing - diagram

5 PROGRAMMING

To enter the programming pages of the instrument, select *PROGRAMMING* from the *MENU* page.

5.1 KEYS



- a) To move the selecting cursor to the available selections.
- b) To change the value of the number identified by the cursor.



- a) To display the page of the selected function.
- b) To enter the programming of a single parameter, activating the cursor on the indicated value.
- c) To confirm the changed value.



- a) To move the cursor on the value to be changed.



- a) To exit the programming MENU and go back to the main MENU.
- b) To exit the programming page and go back to the programming MENU.
- c) To cancel the change of a value.

When exiting each programming page, the message of Pict.5.1 is displayed.

Select:

- *YES* to exit and save the changes;
- *NO* to exit without saving the changes;
- *CONTINUE* not to exit.

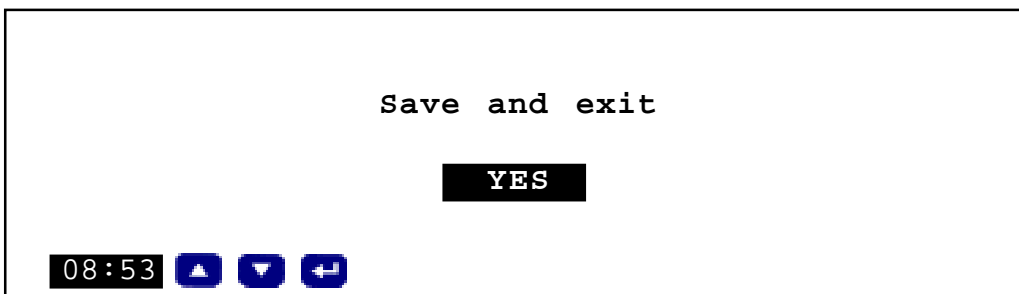

Pict. 5.1 -
Page displayed when exiting
the programming function

5.2 PROGRAMMING MENU

- Main

To program the main operating parameters.

- Printouts

To program the automatic printing.

- Memory

To program the storages into the memory.

- Clock

To set date and time.

- Timeperiods

To program the hours for energy consumption.

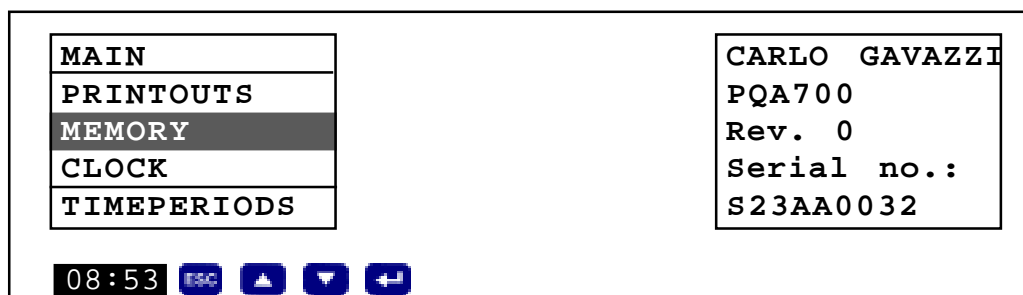





Pict. 5.2 - structure of the programming menu

To exit the programming function and go back to the main MENU, press the **ESC** key.

5.3 MAIN PARAMETERS

Clamp [A/1V]	1000	Language	ENG
VT Ratio	00001	Wiring	3Ph-4W/3CT
Lighten. [sec]	060	Baudrate	38400
Integr.t. [min]	01	Parity	NO

08:53    

Pict. 5.3.1 - programming page of main parameters

- Clamp [A/1V]

Rated value of the output signal of the measuring pliers.

The value of the primary rated current can be set between 1 and 3000A of the amperometric pliers and is always referred to a 1V output.

Clamp [A/1V]	<u>1</u> 000	Language	ENG
VT Ratio	00001	Wiring	3Ph-4W/3CT
Lighten. [sec]	060	Baudrate	38400
Integr.t. [min]	01	Parity	NO

08:53      





Pict. 5.3.2 - programming of the current input

- Ratio VT

Ratio of the primary rated value and the secondary rated value of the voltage transformer (VT) inserted between the line and the instrument. Value to be set between 1 and 10000.

In case of direct connection, enter 00001.

Clamp [A/1V]	1000	Language	ENG
VT Ratio	0 <u>0</u> 001	Wiring	3Ph-4W/3CT
Lighten. [sec]	060	Baudrate	38400
Integr.t. [min]	01	Parity	NO

08:53      

Pict. 5.3.3 - programming of the ratio of the voltage transformer VT

-Lightening

Max time of back-lightening from a key pressure, to be set between 0 and 999s.
Set to zero to keep the back-lightening always switched on.

Clamp [A/1V]	1000	Language	ENG
VT Ratio	00001	Wiring	3Ph-4W/3CT
Lighten. [sec]	060	Baudrate	38400
Integr.t. [min]	01	Parity	NO

08:53 [ESC] [UP] [DOWN] [LEFT] [RIGHT] [ENTER]

Pict. 5.3.4 - programming of the display back-lightening

- Integration time

Integration time for the calculation of average "dmd" power and current displayed. It is possible to select 1, 5, 10, 15, 30 and 60 minutes.

Clamp [A/1V]	1000	Language	ENG
VT Ratio	00001	Wiring	3Ph-4W/3CT
Lighten. [sec]	060	Baudrate	38400
Integr.t. [min]	01	Parity	NO

08:53 [ESC] [UP] [DOWN] [ENTER]

Pict. 5.3.5 - programming of the integration time

- Language

It allows to select the language of the messages displayed by the instrument.
It is possible to select: English or Italian.

Clamp [A/1V]	1000	Language	ENG
VT Ratio	00001	Wiring	3Ph-4W/3CT
Lighten. [sec]	060	Baudrate	38400
Integr.t. [min]	01	Parity	NO

08:53 [ESC] [UP] [DOWN] [ENTER]

Pict. 5.3.6 - programming of the language

- Connection

It is possible to select: 3 ph.-4w./3ct, 3 ph.-3w./2ct and single-phase.

In case of tri-phase measurement, only selecting 3ph.-4w./3ct all parameters are displayed.

For a correct connection of the instrument, refer to connection diagrams (see sect. 2.5).

NOTE: If the neutral connector is not available, it is possible to connect the N terminal of measurement input to the earthing. This way you can set the instrument connection as 4 wires and read all available parameters (for a correct reading, a good earthing is recommended).

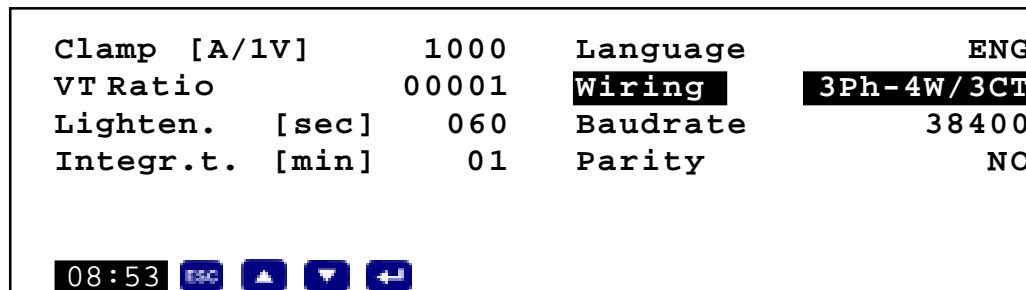

Pict. 5.3.7 - programming of the connection diagram

- Baudrate

Communication speed on the serial line.

It is possible to select: 300, 600, 1200, 2400, 4800, 9600, 19200 and 38400.

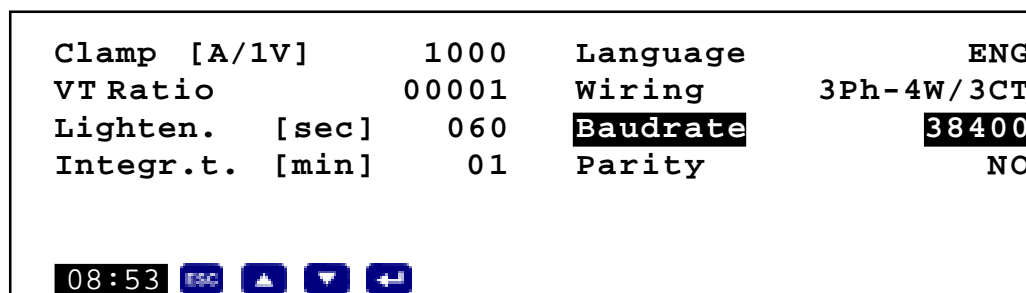

Pict. 5.3.8 - programming of the baudrate

- Parity

Parity generation.

It is possible to select: NO, EVEN, ODD

During communication, 8 bit of data and 1 bit of stop are always used.

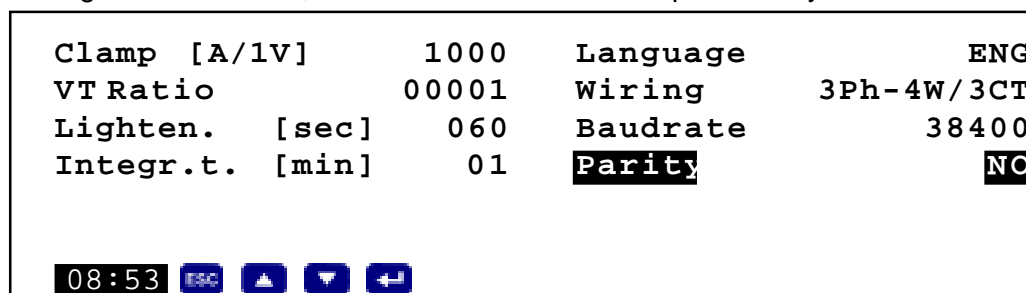

Pict. 5.3.9 - programming of the parity

5.4 PRINT

Programming page of the automatic printing.

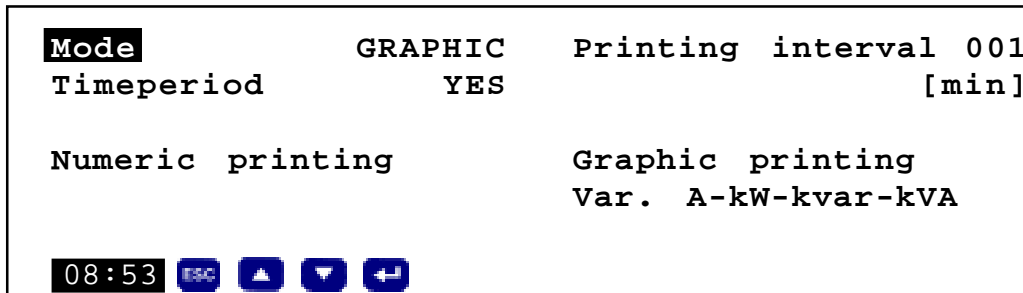

Pict. 5.4.1 - programming page of printing

- Mode

To select the type of automatic printing, among:

- NONE - no printing;
- NUMERIC - printing of the instant measured values as a table;
- GRAPHIC - printing of the instant measured values as a diagram.

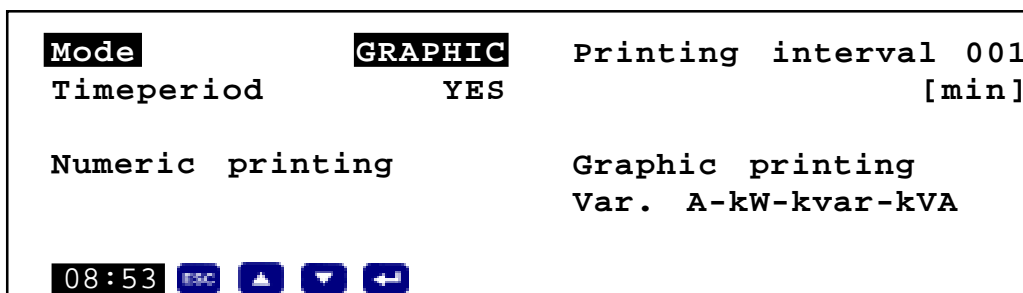

Pict. 5.4.2 - selection of automatic printing

- Printing interval

To establish the printing interval of automatic printing in minutes (tables or diagram).

It is possible to select from 1 to 120 minutes; in the graphic printing by selecting CON the continuous printing is set.

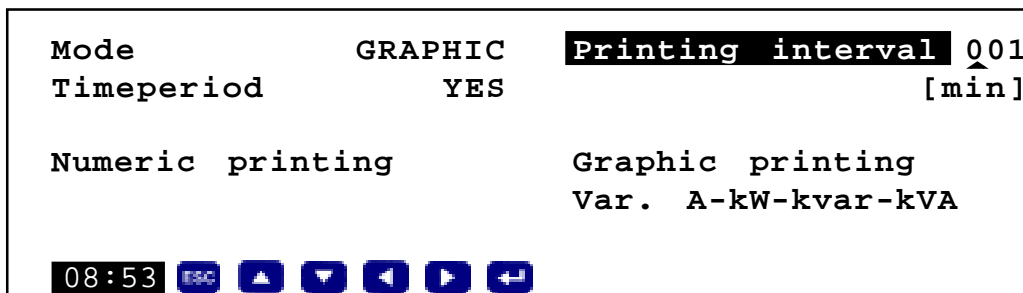

Pict. 5.4.3 - programming of the printing interval

- Timeperiod

If you select "YES", the automatic printing is activated at 00:00 of the energy counters, divided into hours.

Immediately after printing, the counters reset to count the consumption of the new day.

If you select "NO" the instrument doesn't print the counters before the reset. In this case, all data of the energy counters divided into hours of the current day will be cancelled.

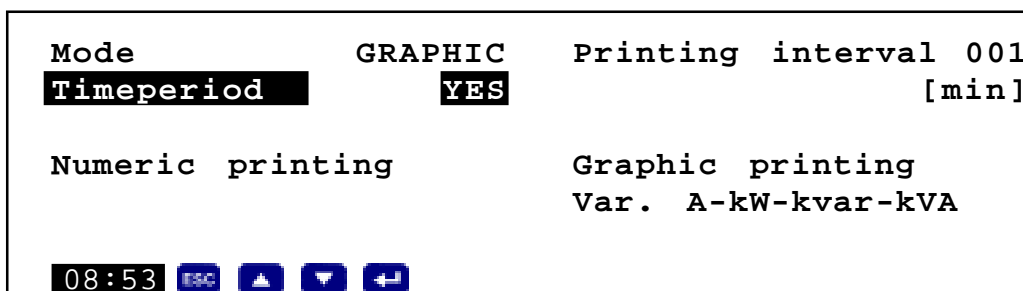

Pict. 5.4.4 - selection of hours printing

Numeric printing

- Var.

To select the variables to be printed.

All different possible combinations depend on the type of connection used in the measurement.

In case of connection 3 Ph - 4 W./3CT it is possible to select among:

```
* V; A; kW; kWdmd; kvar
* V; A; kW; kvar; TPF
* V; kW; kvar; TPF; Hz
* V; kW; kW1; kW2; kW3;
* V; V1; V2; V3; kW;
* V; kW; Vthd1%; Vthd2%; Vthd3%;
* V; kW; Athd1%; Athd2%; Athd3%;
```

In case of connection 3 Ph - 3 W./2CT it is possible to select among:

```
* V; A; kW; kWdmd; kvar
* V; A; kW; kvar; TPF
* V; kW; kvar; TPF; Hz
* V; A; kW; Athd1%; Athd3%;
```

In case of single-phase connection it is possible to select among:

```
* V; A; kW; kWdmd; kvar
* V; A; kW; kvar; TPF
* V; kW; kvar; TPF; Hz
* V; A; kW; Vthd%; Athd%
```

To activate this type of printing, select NUMERIC as a MODE.

```
Mode          NUMERIC      Printing interval 001
Timeperiod    YES          [min]

Numeric printing      Graphic printing
Var. V-A-kW-kvar-TPF

08:53 [ESC] [UP] [DOWN] [LEFT]
```

Pict. 5.4.5 - programming of numeric printing

Graphic printing

- Var.

To select the sizes to be printed.

All different possible combinations depend on the type of connection used in the measurement.

In case of connection 3 Ph - 4 W./3 CT it is possible to select among:

```
* A; kW; kvar; kVA
* A1; kW1; kvar1; kVA1
* A2; kW2; kvar2; kVA2
* A3; kW3; kvar3; kVA3
* V; V1; V2; V3
* A; A1; A2; A3
* kW; kW1; kW2; kW3
* kvar; kvar1; kvar2; kvar3
* TPF; TPF1; TPF2; TPF3
```

In case of connection 3 Ph - 3 W./2 CT it is possible to select among:

```
* A; kW; kvar; kVA
* A; kW; kvar; TPF
* A; A1; A2; A3
```

In case of single-phase connection it is possible to select among:

```
* A; kW; kvar; kVA
* V; A; kW; TPF
```

The scale for the diagram representation is fixed.

Select GRAPHIC as a MODE to activate this type of printing.

```
Mode          GRAPHIC      Printing interval 001
Timeperiod    YES          [min]

Numeric printing      Graphic printing
Var. A-kW-kvar-kVA

08:53 [ESC] [UP] [DOWN] [LEFT]
```

Pict. 5.4.6 - programming of graphic printing

5.5 MEMORY

Programming page of the memory.



Pict. 5.5.1 - programming page of the memory

The instrument can measure and store in the memory different faults of the mains, according to EN50160, depending on the selected type of recording:

1) Memory: **MIN/AVG/MAX**

- Supply voltage variations

In order to prevent this type of fault from occurring, it is necessary that the 95% of the average values calculated every 10 minutes during one week on the supplied voltage, is included in the rated $V_n \pm 10\%$ range.

2) Memory: **Voltage dips**

- Voltage dips

Sudden reduction of the voltage to a value included between 90% and 1% of the declared voltage, followed by a restoring after a short time.

Generally, a voltage dip duration is included between 10ms and 1 minute.

- Short voltage interruption

Condition in which the voltage is lower than 1% of the declared voltage for a time shorter than 3 minutes.

- Long voltage interruption

Condition in which the voltage is lower than 1% of the declared voltage for a time longer than 3 minutes.

- Temporary over-voltage

Temporary over-voltage at mains frequency.

3) Memory: **NONE**

No recording.

If you press the key  you enter the programming page of the selected choice.

5.5.1 VOLTAGE DIPS RECORDING

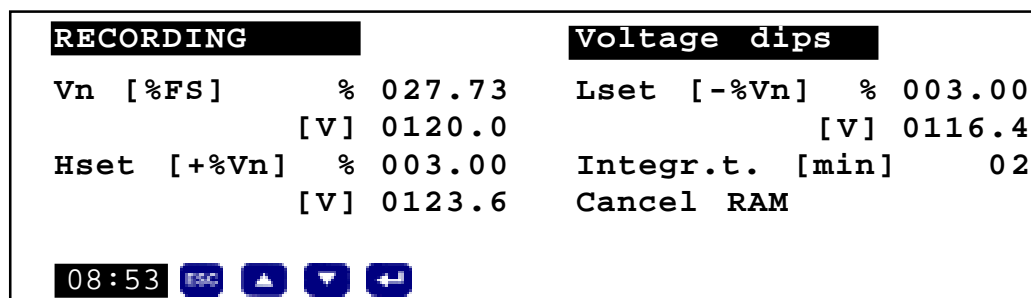

Pict. 5.5.2 - programming page of the voltage dips

IMPORTANT: the recording of the Voltage dips operates only by selecting the connection diagram 3 ph - 4 w./ 3CT.

With parameters set like Pict.5.5.3, the instrument records the voltage faults according to EN50160.

PARAMETER	VOLTAGE DIPS	VOLTAGE INTERRUPTION	TEMPORARY OVER-VOLTAGE
Hset	*	*	> 1% at discretion
Lset	10%	99%	*

Pict. 5.5.3 - programming of parameters to detect faults according to EN50160

* - parameter not influent for the corresponding fault

In case of Lset = 10% setting, the instrument records both voltage dips and interruptions. The instrument doesn't carry out the analysis of faults on a time base, therefore, in order to separate short voltage interruptions from long ones it is necessary to analyse the recorded data downloading them on the PC by means of PQA-Soft software. The Integration time parameter is not contemplated by the standard, and therefore it is left to the user's discretion.

The instrument allows to program the acquisition of voltage faults with two different methods:

- Acquisition with fixed reference value.
- Acquisition with variable reference value.

Acquisition with fixed reference value.

With this operating mode, the voltage reference value, used for the set-points, is fixed and it coincides to the set rated value. (Pict. 5.5.4).

The value of minimum and maximum set-points is expressed as a percentage value referred to the reference value (rated value).

The values of the set-points remain fixed for the whole time of the measurement.

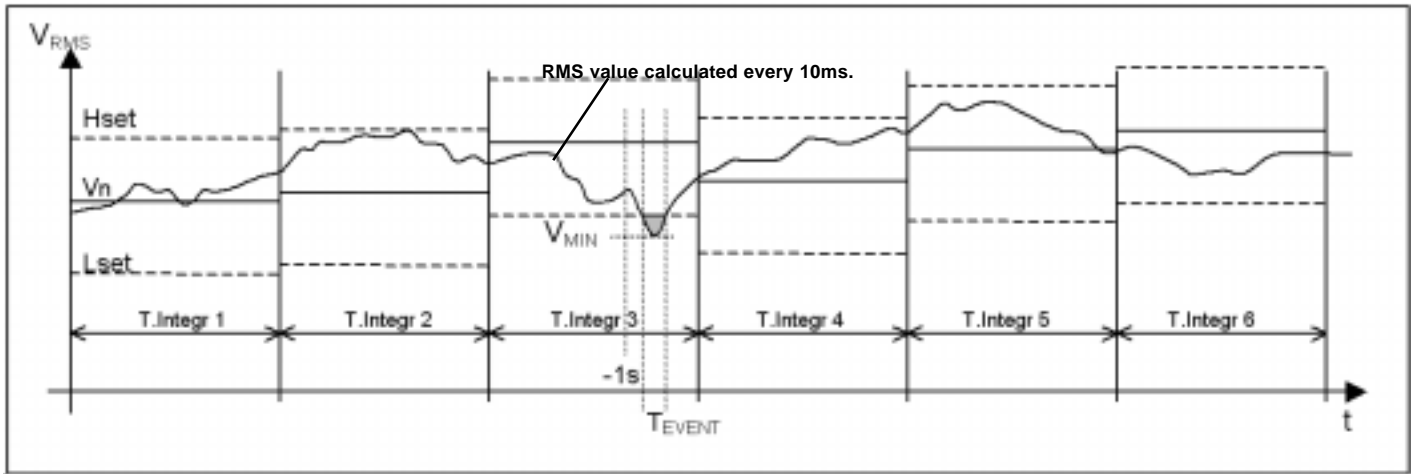

Pict. 5.5.4 - Acquisition with fixed reference value, high set-point intervention

Acquisition with variable reference value.

With the variable mode, the voltage reference value used for set-points is automatically calculated by the instrument at every Integr.T. interval (Pict. 5.5.5).

The voltage value read for each phase is integrated for a period of time that can be set between 1 and 99 minutes. This value is used at the end of the period of time as a reference for the calculation of the set-points of the following period of time.

The value of minimum and maximum set-points is always expressed as a percentage value referred to the reference re-calculated value.

This operating mode allows to follow slow changes of voltage, underlining only the quick events.

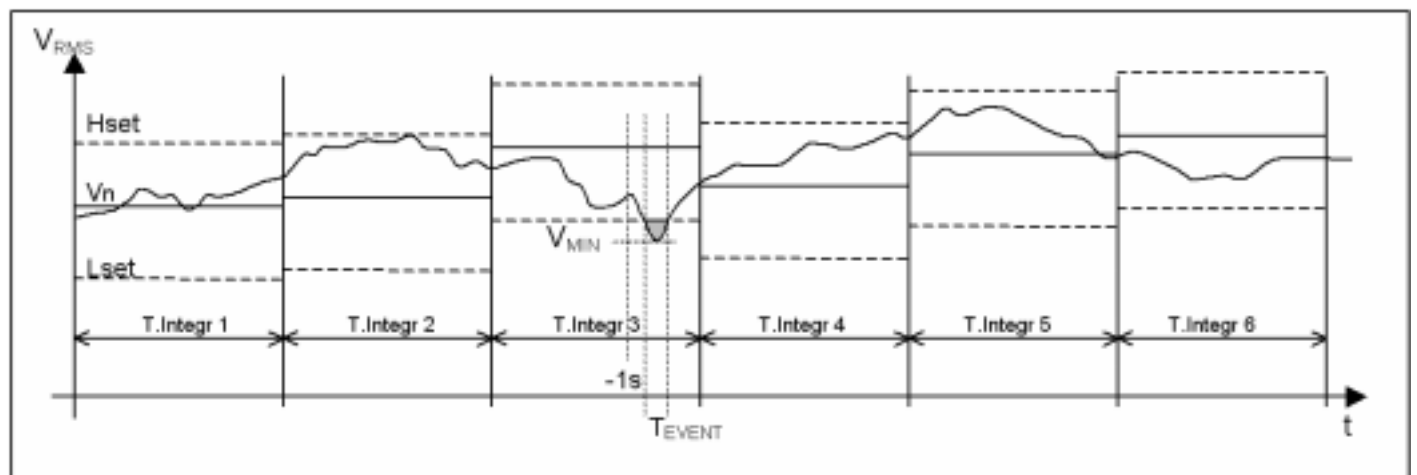

Pict. 5.5.5 - Acquisition with variable reference value, low set-point intervention

- Vn (%FS)

Voltage rated value expressed as a percentage referred to the full-scale of $404V_{L-N}$.

The following value indicates the real value and it is automatically calculated.

In case of programming with variable reference value (Integr.t. parameter not being zero), the rated value is used as a reference to calculate the set-points only for the first considered period of time.

RECORDING	Voltage dips
Vn [%FS] % 027.73	Lset [-%Vn] % 003.00
[V] 0120.0	[V] 0116.4
Hset [%Vn] % 003.00	Integr.t. [min] 02
[V] 0123.6	Clear RAM
08:53	ESC ▲ ▼ ◀ ▶ ↵

Pict. 5.5.6 - programming of the voltage rated value

- Hset (+%Vn)

High set-point. Value over which the over-voltage is recorded. The value is expressed as a percentage change referred to the reference value (+ 1% to + 99%).

The following value indicates the real value and it is automatically calculated.

RECORDING	Voltage dips
Vn [%FS] % 027.73	Lset [-%Vn] % 003.00
[V] 0120.0	[V] 0116.4
Hset [%Vn] % 003.00	Integr.t. [min] 02
[V] 0123.6	Clear RAM
08:53	ESC ▲ ▼ ◀ ▶ ↵

Pict. 5.5.7 - programming of the high set-point

- Lset (-%Vn)

Low set-point. Value under which the voltage dip or the mains interruption are recorded. The value is expressed as a percentage change referred to the reference value (- 1% to - 99%).

The following value indicates the real value and it is automatically calculated.

With Lset=10% value set, the instrument records all voltage reductions with values lower than 90% of the reference value (voltage dips and interruptions); with Lset=99% value set, the instrument records all voltage reductions with values lower than 1% of the reference value (only voltage interruptions).

RECORDING	Voltage dips
Vn [%FS] % 027.73	Lset [-%Vn] % 003.00
[V] 0120.0	[V] 0116.4
Hset [%Vn] % 003.00	Integr.t. [min] 02
[V] 0123.6	Clear RAM
08:53	ESC ▲ ▼ ◀ ▶ ↵

Pict. 5.5.8 - programming of the low set-point

- Integr.t.

Integration time to calculate the reference voltage in the "variable" mode (to set between 0 and 99 minutes). The "variable reference voltage" is activated by setting the integration time. If the value is set to 0, the "fixed" mode is automatically selected.

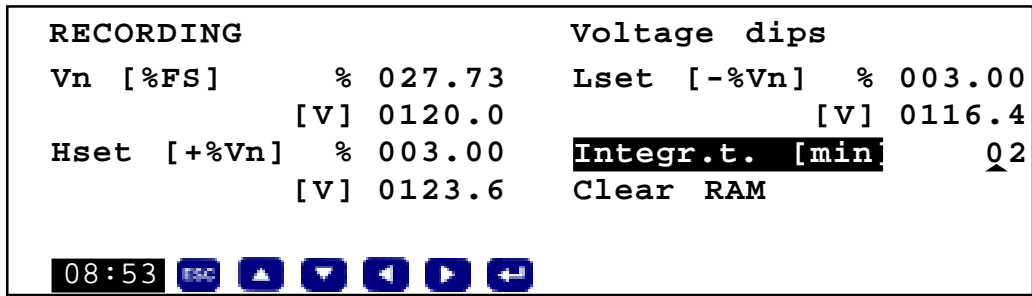

Pict. 5.5.9 - programming of the integration time

- Clear RAM

To clear data already recorded in RAM. By confirming the message, the instrument displays the message "RAM Cleared".

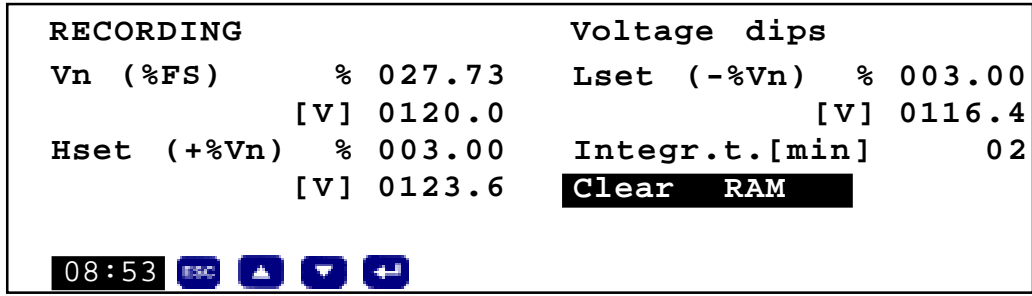

Pict. 5.5.10 - cancel the recordings in the RAM

5.5.2 RECORDING MIN/AVG/MAX

Programming page for recording of minimum, average and maximum value of the selected sizes at the set intervals.

RECORDING		MIN / AVG / MAX	
MODE	FIFO	Start	10:00
Integr.t. [sec]	900		
Variable			
V1-V2-V3-A1-A2-A3-kW-kW1-kW2-kW3			
08:53	ESC	▲	▼

Pict. 5.5.11 - MIN/AVG/MAX programming page

This function allows the continuous sampling of the measurement and it offers the opportunity to record the minimum, average and maximum value of the set sizes, in order to carry out the analysis of the mains quality according to standard EN50160.

To carry out the continuous sampling, the instrument uses a second microprocessor allowing to acquire and calculate the following electric sizes: V, V1, V2, V3, A, A1, A2, A3, P, P1, P2, P3, Q, Q1, Q2, Q3, S, S1, S2, S3, PF, PF1, PF2, PF3, F.

The calculation of the RMS value is carried out for each period of time (20 msec at 50Hz); the integration time for the calculation of the average value can be set between 1 and 900 seconds.

The instrument records the average value at the end of each set integration interval and, in addition to that, for each interval it records the minimum and maximum value with reference to the related period of time.

- Recording mode

To select the recording management mode in the RAM of minimum, average and maximum value between:

- FIFO - recording of latest data acquired by overwriting the oldest ones;
- STACK - recording of data till the complete filling of the RAM.

Attention: In case of STACK recording, the filling up of the RAM is indicated in the page "RECORDS" (s.chapt.4.7) by "OFF" in the "Status" line.

RECORD		MIN / AVG / MAX	
MODE	FIFO	Start	10:00
Integr.t. [sec]	900		
Variable			
V1-V2-V3-A1-A2-A3-kW-kW1-kW2-kW3			
08:53	ESC	▲	▼

Pict. 5.5.12 - programming of the recording management mode of the RAM

- Start

Start of recording in hours and minutes.

Range to be set between 00:00 and 23:59.

The parameter operates only when the STACK recording mode is activated.

RECORD		MIN / AVG / MAX	
MODE	FIFO	Start	10:00
Integr.t. [sec]	900		
Variable			
V1-V2-V3-A1-A2-A3-kW-kW1-kW2-kW3			
08:53	ESC	▲	▼

Pict. 5.5.13 - programming of the recording start

- Integration time

Integration time to calculate the average value expressed in seconds.
It can be set from 1 to 999 seconds.

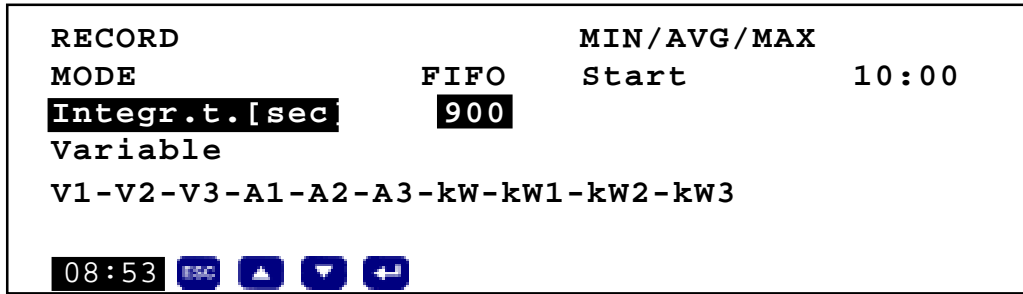

Pict. 5.5.14 - programming of the integration time

With the Integr.t.=600 (10 minutes) value set, you can keep the instrument recording for at least one week; it will record all necessary information to analyse and detect, by means of PqaSoft software, all supplied voltage changes, according to EN50160.

- Variable

To select the sizes to be recorded.

All different possible combinations depend on the type of connection used in the measurement.

In case of 3 ph - 4 w./3CT connection diagram it is possible to select among:

- * V - A - kW - kVA - kvar - TPF - Hz
- * V1 - A1 - kW1 - kVA1 - kvar1 - TPF1
- * V2 - A2 - kW2 - kVA2 - kvar2 - TPF2
- * V3 - A3 - kW3 - kVA3 - kvar3 - TPF3
- * V1 - V2 - V3 - A1 - A2 - A3 - kW - kW1 - kW2 - kW3
- * kW - kW1 - kW2 - kW3 - kvar - kvar1 - kvar2 - kvar3
- * kW - kW1 - kW2 - kW3 - TPF - TPF1 - TPF2 - TPF3

In case of 3 ph - 3 w./2CT connection diagram it is possible to select among:

- * V - A - kW - kVA - kvar - TPF - Hz
- * V - A - A1 - A2 - A3 - kW - kVA - kvar - TPF - Hz
- * V - A1 - A2 - A3 - kW
- * kW - kvar - kVA - TPF

In case of single-phase connection diagram it is possible to select among:

- * V - A - kW - kVA - kvar - TPF - Hz
- * V - A - kW
- * kW - kvar - kVA - TPF

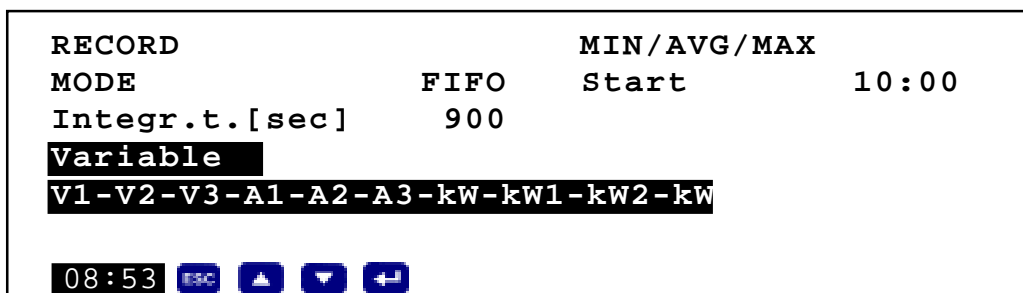

Pict. 5.5.15 - programming of the sizes to be selected

5.6 CLOCK / CALENDAR

The instrument allows to display the date and time in the European or American format.

Warning: the clock is stopped while changing date and time.

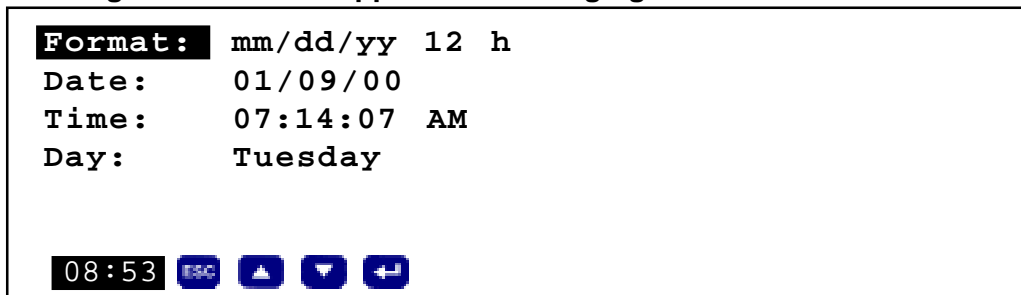

Pict. 5.6.1 - programming page of the clock

- Format

To select the format to display date/time; it is possible to select between:

- dd/mm/yy hh:mm:ss (European standard);
- mm/dd/yy hh:mm:ss tt (American standard).

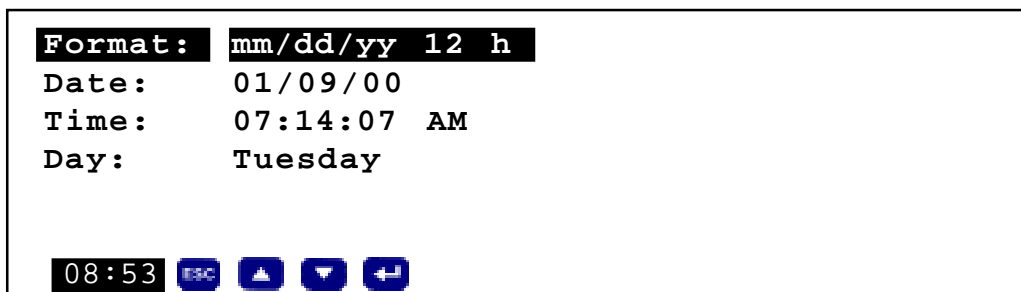

Pict. 5.6.2 - programming the format of date / time

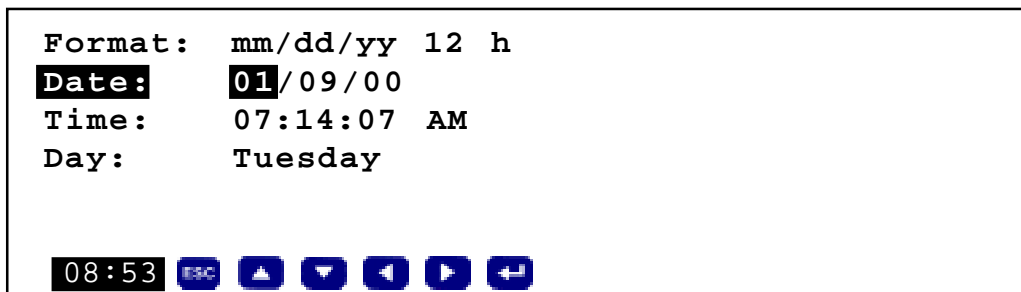

Pict. 5.6.3 - programming the date

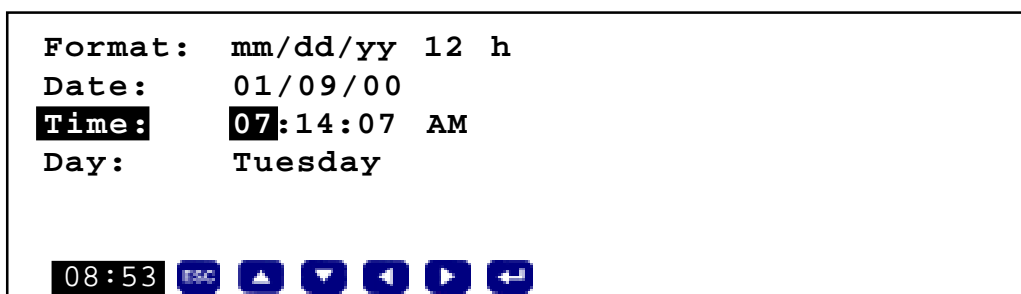

Pict. 5.6.4 - programming the time

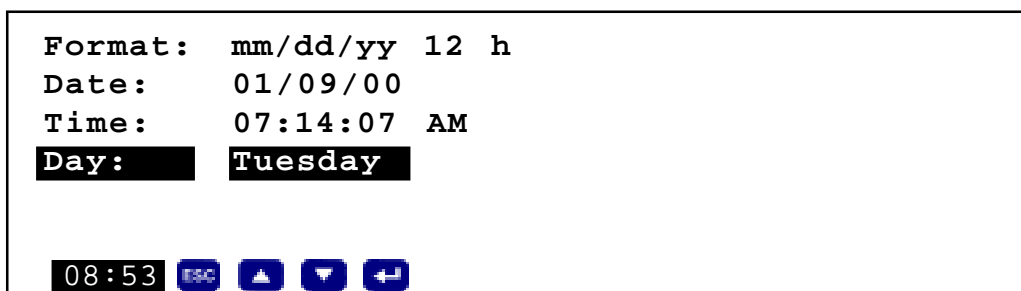





Pict. 5.6.5 - programming the day of the week

5.7 HOURS AND TARIFFS

It is possible to set up to 10 periods in one year, with changes of tariffs different among each other.





Period	01	Period	06
Period	02	Period	07
Period	03	Period	08
Period	04	Period	09
Period	05	Period	10

08:53    

Pict. 5.7.1 - programming page of hours

When you select a period, the programming page is displayed and it's possible to set up to 8 different changes of tariffs during one day; this programming can be associated to various days of the week and months of the year (see example 5.7.1).

Hour 1	00:00	3	Hour 6	18:30	2	P01
Hour 2	06:30	2	Hour 7	21:30	3	
Hour 3	08:30	1	Hour 8	00:00	0	
Hour 4	10:30	2	Month/day			
Hour 5	16:30	1				





08:53    

Pict. 5.7.2 - programming page of the selected period

- Hour 1...8

To establish the beginning (hours/minutes) of a tariff hour; the hours end at the beginning of the following one. The maximum amount of hours change is 8 and for each one it is possible to set three different tariffs: 1, 2, 3. Set tariff "0" to establish the daily programming; no value is indicated in the lines following the one containing the tariff 0 is acknowledged.

Hour 1	00:00	3	Hour 6	18:30	2	P01
Hour 2	06:30	2	Hour 7	21:30	3	
Hour 3	08:30	1	Hour 8	00:00	0	
Hour 4	10:30	2	Month/day			
Hour 5	16:30	1				





08:53    

Pict. 5.7.3 - programming hour/minute - hours start/end

- Month/Day

To establish days and months involved in the set period.

Hour 1	00:00	3	Hour 6	18:30	2	P01
Hour 2	06:30	2	Hour 7	21:30	3	
Hour 3	08:30	1	Hour 8	00:00	0	
Hour 4	10:30	2	Month/Day			
Hour 5	16:30	1				

08:53    

Pict. 5.7.4 - programming month/day

The page displayed later allows to select the day of the week and the months of the year involved in the set period.

Controls:

- to move the cursor in the page.
- activate/deactivate the day identified by the cursor.

	J	F	M	A	M	J	J	A	S	O	N	D	P01
MON	*	*	*							*	*	*	
TUE	*	*	*							*	*	*	
WED	*	*	*							*	*	*	
THU	*	*	*							*	*	*	
FRI	*	*	*							*	*	*	
SAT	X	X	X							X	X	X	
SUN													

08:53

Pict. 5.7.5 - selection of the day of the week and month of the year involved in the set period

Legend:

- * - selected day in the current period
- X - selected day in another period

Note: If one day has been selected in a certain period, it can no more be selected for another period.

Attention: the consumption data of time bands and days not programmed, are inserted in tariff 3 automatically (empty hours).

Example 5.8.1
Example of programming of hours in the period October - March.

Period	Days	Tariffs
1	Mon to Fri	T1-T2-T3
2	Sat	T2-T3
	Sun (not set)	T3 (auto)

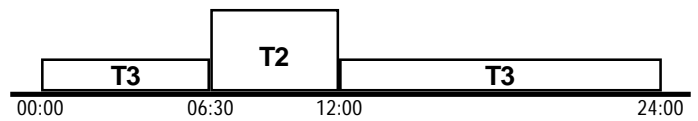
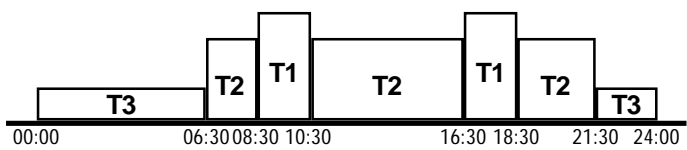

PERIOD	MONTH	DAY	HOUR/TARIFF
PERIOD1	OCTOBER	MONDAY	00:00 = T3
	NOVEMBER	TUESDAY	06:30 = T2
	DECEMBER	WEDNESDAY	08:30 = T1
	JANUARY	THURSDAY	10:30 = T2
	FEBRUARY	FRIDAY	16:30 = T1
	MARCH		18:30 = T2
			21:30 = T3
		00:00 = T0	

PERIOD	MONTH	DAY	HOUR/TARIFF
PERIOD2	OCTOBER	SATURDAY	00:00 = T3
	NOVEMBER		06:30 = T2
	DECEMBER		12:00 = T3
	JANUARY		00:00 = T0
	FEBRUARY		
	MARCH		

6 PqaSoft

6.1 INTRODUCTION

The function of this software application is to program the PQA700 instruments, display the acquired measurement and transfer the data stored in the RAM to the PC.

The software allows:

- to display all electric measurement acquired by the examined instrument with its own serial number;
- to transfer all data stored in the RAM to a file;
- to analyse the data downloaded by the instrument;
- to set the operating parameters of the instrument.

6.1.1 HARDWARE REQUIREMENTS

- PC with Pentium® 150 MHz processor or higher.
- Microsoft® Windows 95, 98 or Windows NT® 4.0 Workstation operating system.
- RAM 16MB for Windows® 95 and 98; 32MB for Windows NT®.
- 10MB free on the hard disk.
- Mouse.
- RS232 serial port.

6.1.2 INSTALLATION ON HARD DISK

Procedure for installation on Hard-Disk.

1. Switch the PC on and wait for the complete loading of MicroSoft WINDOWS.
2. Insert the CD in the CD-reader.
3. Select Start and then Execute; the dialogue window Execute will be displayed.
4. Write D:\SETUP (or <cd drive>:\SETUP) in the control line and click <ENTER>.

The installation program will automatically:

- create a new folder <PqaSoft>;
- copy in it all files necessary to use the program correctly.

5. At the end of installation, the set of **PqaSoft** files will be displayed.
6. Launch the program by double-clicking on the **PqaSoft** icon.

6.1.3 ACCESS THE PROGRAM

















From MicroSoft WINDOWS, left-click the **PqaSoft** icon twice.

Before the real activation of the program, a presentation window of the software will be displayed. Press any key to close it and launch the program.

The window displayed with the program activation allows the setting of all parameters related to the serial line and the serial number of the instrument to be examined. The serial number displayed on the screen refers to the latest examined instrument.

6.1.4 TOOL BAR

The tool bar is displayed in the upper part of the application window, below the menu bar. It allows the quick access to the most frequent selections by means of the mouse.

- Click on to:
- [Shift + F9]  Open the dialogue window of Instrument programming.
 - [F8]  Store the displayed data in Excel compatible files.
 -  Print.
 - [F1]  Open the Instant Values page.
 - [F2]  Open the Panel page.
 - [F3]  Open the Trend page.
 - [F4]  Open the Samples & FFT page.
 - [F5]  Open the Min/Max values page.
 - [F6]  Open the page of consumption divided into Hours.
 - [F7]  Open the page for the Analysis of transferred data.
 - [F9]  Open the file to be analysed.
 -  Display table.
 -  Display diagram.
 -  Display the analysis page.
 -  Search for min/max.
 -  Search for date/time.
 - [Alt + F4]  Exit from **PqaSoft**.

6.1.5 STATUS BAR

The status bar is displayed in the lower part of the **PqaSoft** window.

In the left area, it describes the action related to controls that can be selected by means of the arrows used to move within the menus. This area also displays the description messages related to the function of the tool bar buttons when pressed. If, after description, you don't want to press it, just move outside the button and then release the mouse button.

In the right area, the status bar indicates the serial number of the connected instrument.

6.2 DISPLAY MENU

The Display menu has the following controls:

Real Time	F1
Panel page	F2
Trends page	F3
Samples & FFT	F4
Min/Max	F5
Time Periods	F6
Analysis	F7
<hr/>	
Save	F8
Open	F9
<hr/>	
Print...	
Print Setup...	
<hr/>	
Exit	Alt+F4

- **Real Time** - It displays a page with the Real Time.
- **Panel Page** - It displays a page with fifteen indication instruments.
- **Trend Page** - It displays a page with the Instant Values diagram.
- **Samples & FFT** - It displays a page with the diagrams of the first 50 harmonics of voltage and line current.
- **Min/Max** - It displays a page with the Min and Max value of sizes with indication of the related date and time.
- **Time Periods** - It displays a page with the energy consumption divided into programmable time periods. Indication of the current day.
- **Analysis** - It displays a page for the analysis of recording files transferred from the instrument to the PC.
- **Save** - It stores the data contained in the Min/Max and Timeperiods pages on files.
- **Open** - It opens a recording file for data analysis.
- **Print** - It prints according to selected setting.
- **Print Setup** - It displays the print setup page.
- **Exit** - It exits from the **PqaSoft** program.

6.2.1 INSTANT VALUES PAGE - [F1]

To be used to display the real time page with all instant values measured by the connected instrument. The variables indicated depend on the selected connection diagram.

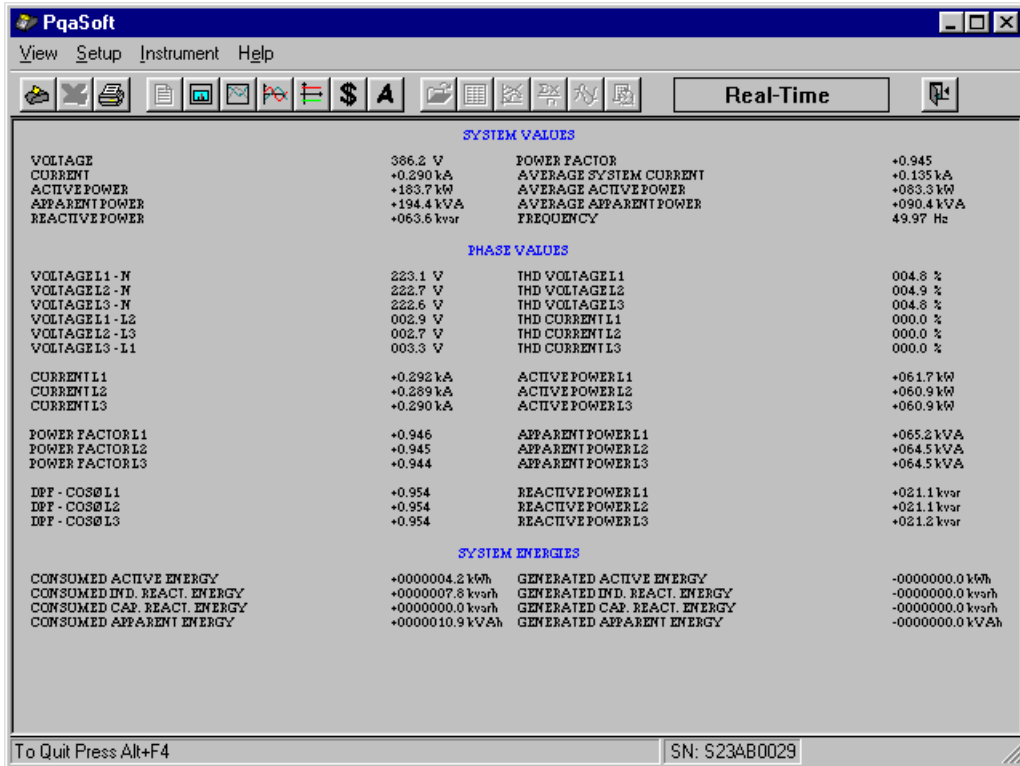

The screenshot shows the 'PqaSoft' application window with a 'Real-Time' button highlighted. The main display area is divided into several sections: SYSTEM VALUES, PHASE VALUES, and SYSTEM ENERGIES. Each section contains a list of electrical parameters and their current values.

SYSTEM VALUES			
VOLTAGE	386.2 V	POWER FACTOR	+0.945
CURRENT	+0.290 kA	AVERAGE SYSTEM CURRENT	+0.135 kA
ACTIVE POWER	+183.7 kW	AVERAGE ACTIVE POWER	+83.3 kW
APPARENT POWER	+194.4 kVA	AVERAGE APPARENT POWER	+90.4 kVA
REACTIVE POWER	+063.6 kvar	FREQUENCY	49.97 Hz
PHASE VALUES			
VOLTAGE L1 - N	223.1 V	THD VOLTAGE L1	004.8 %
VOLTAGE L2 - N	222.7 V	THD VOLTAGE L2	004.9 %
VOLTAGE L3 - N	222.6 V	THD VOLTAGE L3	004.8 %
VOLTAGE L1 - L2	002.9 V	THD CURRENT L1	000.0 %
VOLTAGE L2 - L3	002.7 V	THD CURRENT L2	000.0 %
VOLTAGE L3 - L1	003.3 V	THD CURRENT L3	000.0 %
CURRENT L1	+0.292 kA	ACTIVE POWER L1	+061.7 kW
CURRENT L2	+0.289 kA	ACTIVE POWER L2	+060.9 kW
CURRENT L3	+0.290 kA	ACTIVE POWER L3	+060.9 kW
POWER FACTOR L1	+0.946	APPARENT POWER L1	+065.2 kVA
POWER FACTOR L2	+0.945	APPARENT POWER L2	+064.5 kVA
POWER FACTOR L3	+0.944	APPARENT POWER L3	+064.5 kVA
DPF - COSØ L1	+0.954	REACTIVE POWER L1	+021.1 kvar
DPF - COSØ L2	+0.954	REACTIVE POWER L2	+021.1 kvar
DPF - COSØ L3	+0.954	REACTIVE POWER L3	+021.2 kvar
SYSTEM ENERGIES			
CONSUMED ACTIVE ENERGY	+0000004.2 kWh	GENERATED ACTIVE ENERGY	-0000000.0 kWh
CONSUMED IND. REACT. ENERGY	+0000007.8 kvarh	GENERATED IND. REACT. ENERGY	-0000000.0 kvarh
CONSUMED CAP. REACT. ENERGY	+0000000.0 kvarh	GENERATED CAP. REACT. ENERGY	-0000000.0 kvarh
CONSUMED APPARENT ENERGY	+0000010.9 kVAh	GENERATED APPARENT ENERGY	-0000000.0 kVAh

At the bottom of the window, there is a status bar with the text 'To Quit Press Alt+F4' on the left and 'SN: S23AB0029' on the right.

This menu item is not activated if the currently displayed page is already the Instant page.

The refresh time of the value on the screen depends on the condition of the serial line. Generally, an average time of 0.8 seconds is necessary.

6.2.2 PANEL PAGE - [F2]

To be used to display the Panel page. In this page the fifteen indication panels are displayed. See section 6.3.2. for this page configuration.

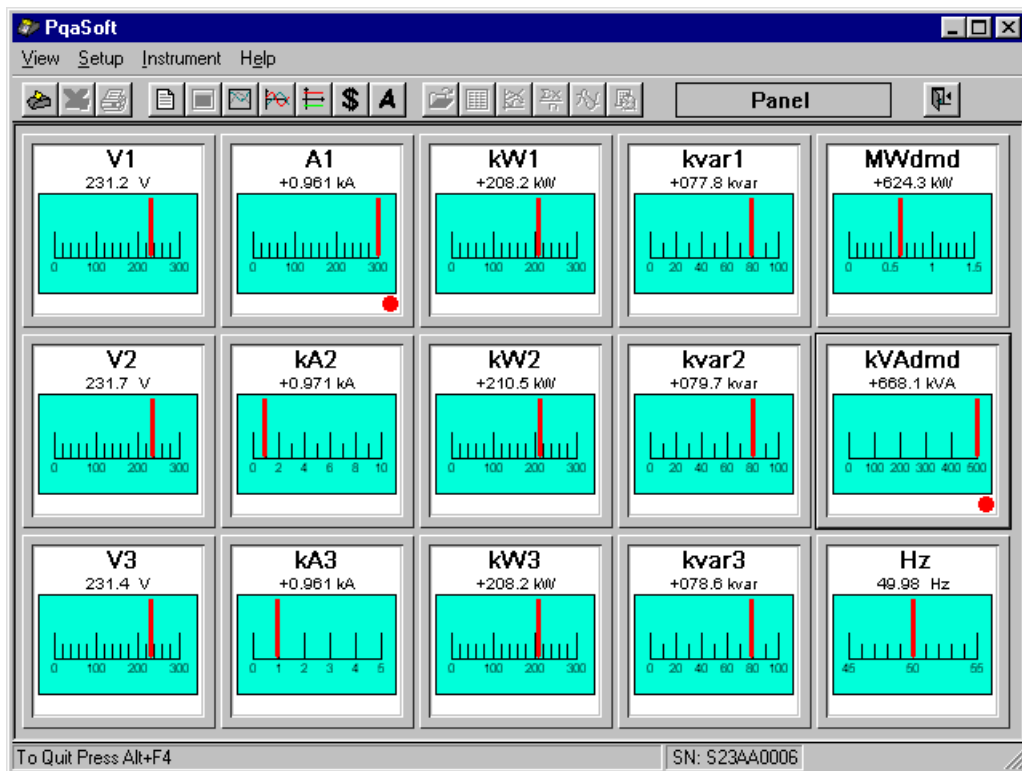

This menu item is not activated if the currently displayed page is already the Panel page.

Should the communication with the instrument be incorrect or is no more possible to measure the set variables since the wiring diagram has been modified, the displayed value is "-----".

If the measure to be displayed exceeds the full scale set for the specific indicator, a red sign is displayed; to be always readable the numeric indication set the proper full scale automatically.

If you select "**None**" in the configuration dialogue window, the indicator will not be displayed on the small panel.

The refresh time of the value on the screen depends on the condition of the serial line. Generally, an average time of 0.8 seconds is necessary.

6.2.3 TREND PAGE - [F3]

To be used to display the Trend page. In this page three diagrams are displayed. See section 6.3.1 for this page configuration.

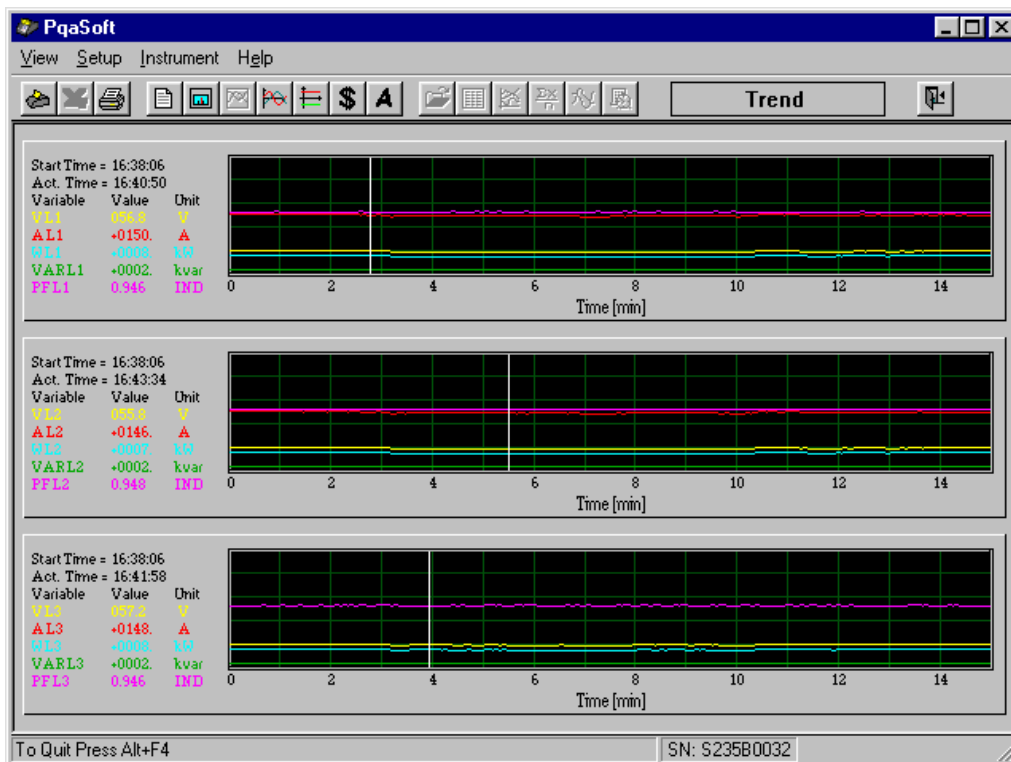

This menu item is not activated if the currently displayed page is already the Trend page.

If you left-click on one of the diagrams, a vertical line appears and the instant value of all tracks is displayed on the left side, with the related time and the record beginning time.

The tracks are erased when the passed time corresponds to the time of the selected full-scale; if you select "Scrolling window" in the trend setting (see section 6.3.1), once the time passed corresponds to the one selected as a full-scale, the diagram will slide on the left erasing the trends related to the oldest times.

6.2.4 SAMPLES & FFT PAGE - [F4]

To be used to display the FFT values page. In this page six diagrams are displayed. See section 6.3.3. for this page configuration.

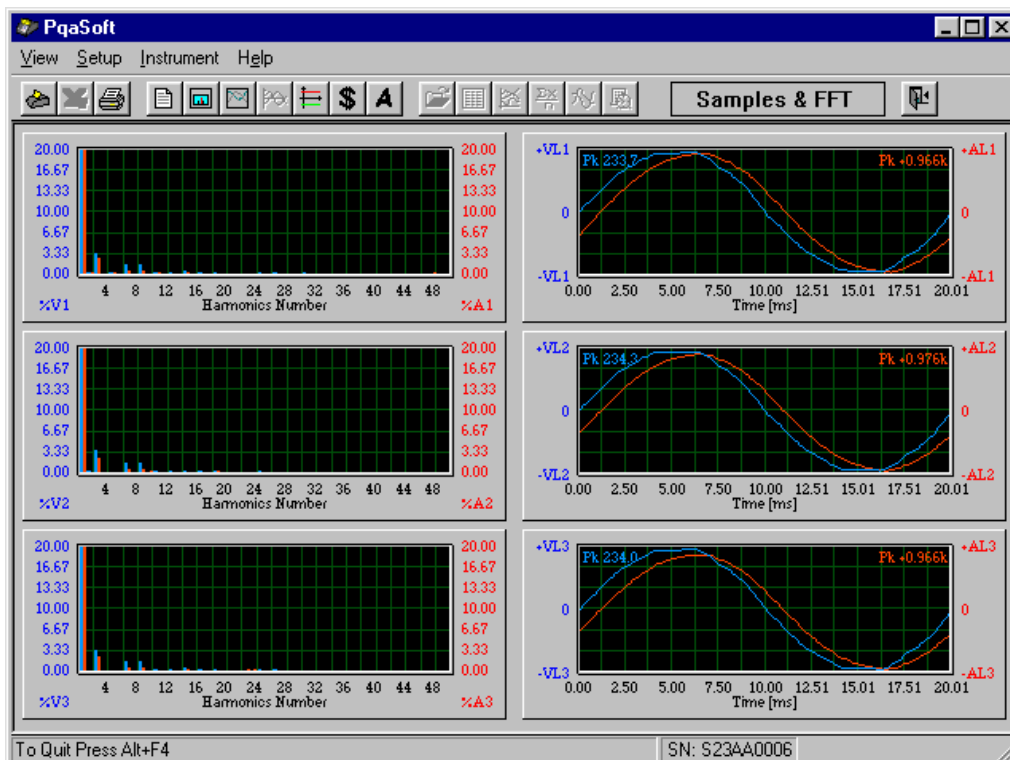

This menu item is not activated if the currently displayed page is already the Samples & FFT page.

The three diagrams on the left of the screen display the first 50 harmonics of voltage and line current, calculated according to the FFT model (Fast Fourier Transform). The upper diagram displays the harmonic content of the line voltage V1 (blue bar) and of the line current A1 (red bar), the middle one displays the harmonic content of the line voltage V2 and of the line current A2, the lower one displays the harmonic content of the line voltage V3 and of the line current A3.

The three diagrams on the right of the screen track the wave form of a period.

The upper diagram displays the line voltage V1 (blue track) and the line current A1 (red track), the middle one displays the line voltage V2 and the line current A2, the lower one displays the line voltage V3 and the line current A3.

6.2.5 MIN/MAX PAGE- [F5]

To be used to display the Min/Max values page. In this page all the min/max values are displayed with indication of related date and time.

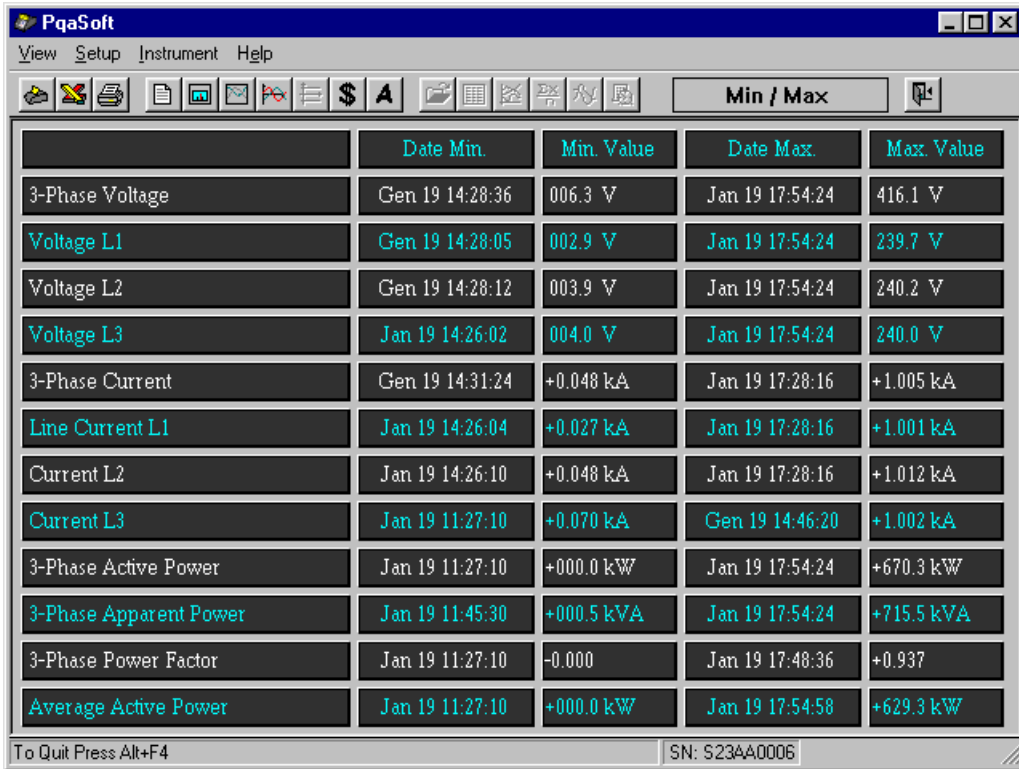

	Date Min.	Min. Value	Date Max.	Max. Value
3-Phase Voltage	Gen 19 14:28:36	006.3 V	Jan 19 17:54:24	416.1 V
Voltage L1	Gen 19 14:28:05	002.9 V	Jan 19 17:54:24	239.7 V
Voltage L2	Gen 19 14:28:12	003.9 V	Jan 19 17:54:24	240.2 V
Voltage L3	Jan 19 14:26:02	004.0 V	Jan 19 17:54:24	240.0 V
3-Phase Current	Gen 19 14:31:24	+0.048 kA	Jan 19 17:28:16	+1.005 kA
Line Current L1	Jan 19 14:26:04	+0.027 kA	Jan 19 17:28:16	+1.001 kA
Current L2	Jan 19 14:26:10	+0.048 kA	Jan 19 17:28:16	+1.012 kA
Current L3	Jan 19 11:27:10	+0.070 kA	Gen 19 14:46:20	+1.002 kA
3-Phase Active Power	Jan 19 11:27:10	+000.0 kW	Jan 19 17:54:24	+670.3 kW
3-Phase Apparent Power	Jan 19 11:45:30	+000.5 kVA	Jan 19 17:54:24	+715.5 kVA
3-Phase Power Factor	Jan 19 11:27:10	-0.000	Jan 19 17:48:36	+0.937
Average Active Power	Jan 19 11:27:10	+000.0 kW	Jan 19 17:54:58	+629.3 kW

This menu item is not activated if the currently displayed page is already the Min/Max page.

PqaSoft can read the instant values directly from the instrument and it records the minimum and maximum values of the indicated sizes with corresponding date/time in this page. It is possible to reset manually these values from the dialogue windows for counter reset (see sect. 6.4.1.8).

Note: Every time that a new instrument is connected, PqaSoft automatically resets those values, asking the user whether he desires to save the MIN/MAX values acquired from the previously connected instrument (see sect. 6.2.8).

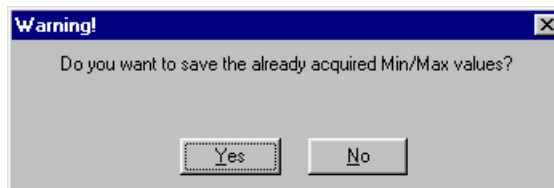

There are five columns: the first one contains the description of the variable; the second, the date and time related to the minimum value; the third, the minimum value; the fourth, date and time related to the maximum value, the fifth, the maximum value.

The date format is the following: "month" "day" "hours: minutes : seconds".

All the displayed data are updated at every acquisition.

Press  and the displayed data will be saved in an EXCEL compatible file (see section 6.2.8).

6.2.6 TIME PERIODS - [F6]

To be used to display the Hours page. In this page the daily energy counters are displayed, divided into three tariff hours: Active, Inductive Reactive, Capacitive Reactive and Apparent Energy (acquired and yielded energies).

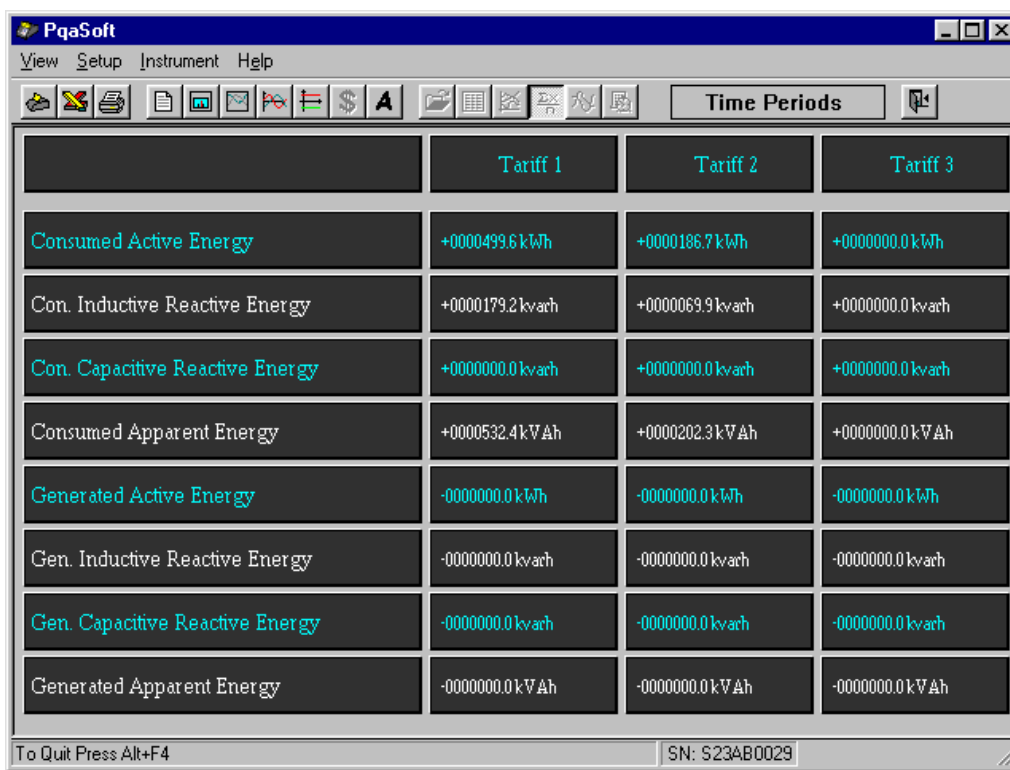

	Tariff 1	Tariff 2	Tariff 3
Consumed Active Energy	+0000499.6 kWh	+0000186.7 kWh	+0000000.0 kWh
Con. Inductive Reactive Energy	+0000179.2 kvarh	+0000069.9 kvarh	+0000000.0 kvarh
Con. Capacitive Reactive Energy	+0000000.0 kvarh	+0000000.0 kvarh	+0000000.0 kvarh
Consumed Apparent Energy	+0000532.4 kVAh	+0000202.3 kVAh	+0000000.0 kVAh
Generated Active Energy	-0000000.0 kWh	-0000000.0 kWh	-0000000.0 kWh
Gen. Inductive Reactive Energy	-0000000.0 kvarh	-0000000.0 kvarh	-0000000.0 kvarh
Gen. Capacitive Reactive Energy	-0000000.0 kvarh	-0000000.0 kvarh	-0000000.0 kvarh
Generated Apparent Energy	-0000000.0 kVAh	-0000000.0 kVAh	-0000000.0 kVAh

To Quit Press Alt+F4 SN: S23AB0029

This menu item is not activated if the currently displayed page is already the Hours page.

There are four columns: the first one contains the variable description; the second, the values of the energy counters corresponding to tariff hour 01; the third, the values of the energy counters corresponding to tariff hour 02 and the fourth, the values of the energy counters corresponding to tariff hour 03. All the displayed values are updated every second, approximately (the refresh time of the value on the screen depends on the condition of the serial line).

At the end of the day, at 24:00, all the values are reset; in the PQA700 instrument is possible to program the automatic print of the counters at the end of the day (see section 6.4.1.5).

Press  and the displayed data will be saved in an EXCEL compatible file (see section 6.2.8).

6.2.7 ANALYSIS - [F7]

To be used to display the page for the analysis of records performed by the instrument and transferred to the PC.

6.2.8 SAVE - [F8]

To be used to store the Min/Max values or those of the energy counters divided into time periods in a Excel compatible file. This button is activated only when the Min/Max and Hours pages are displayed.

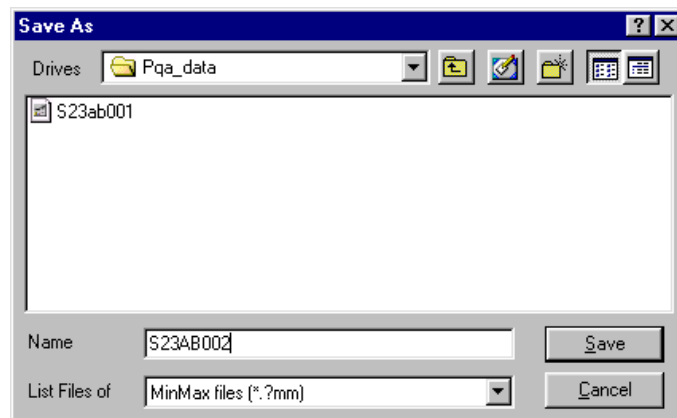

The name suggested to save the file consists of the first 8 characters or digits of the serial number of the connected instrument. Anyway, it's possible to give the file another name.

The file extension consists in the ninth digit of the instrument serial number, plus **TP** (Time Periods) in case of hours file, or **MM** in case of min/max file. All the files are in ASCII format.

6.2.9 OPEN - [F9]

To be used to open a file from the archive, to be analysed.

This button is activated only when the Analysis page is displayed.

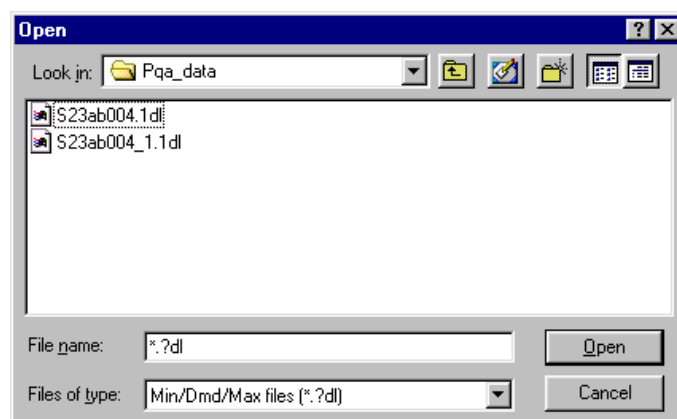

The extension of the archive files that can be opened consists of the ninth digit of the instrument serial number, plus **VV** (voltage Dips) in case of the voltage dips archive, or **DL** (Data Limits) in case of min/avg/max.

6.2.10 PRINT -

To be used to display the dialogue window for the printing.

The appearing dialogue window depends on the displayed page:

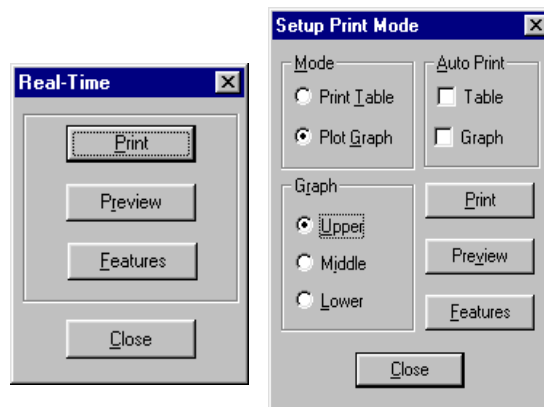

Print

it prints the measurement related to the displayed page.

Preview

it displays the possible print on paper, according to selected settings.

Features

it displays the dialogue window related to printing settings; it allows to select:

- paper orientation;
- printing font in use;
- page margin.

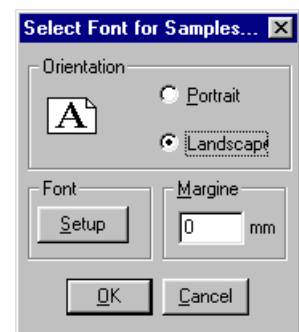

From the Trend page it is possible to print the 3 diagrams displayed in the page, individually, in graphic format, or as a table.

It is also possible to activate the Trend printing automatically. In this latter case, PqaSoft will automatically print the diagram, the table or both with a regular interval. The printing interval depends on the schedule set for each Trend.

From the Samples & FFT page it is possible to print the diagrams displayed in the page in graphic format, or as a table. In case of print of a table, the 3 diagrams will be gathered in only one print. It is also possible to select the print of the wave form, or the print of the harmonics.

6.2.11 PRINTER SETTING

To be used to display the dialogue window for computer printer settings.

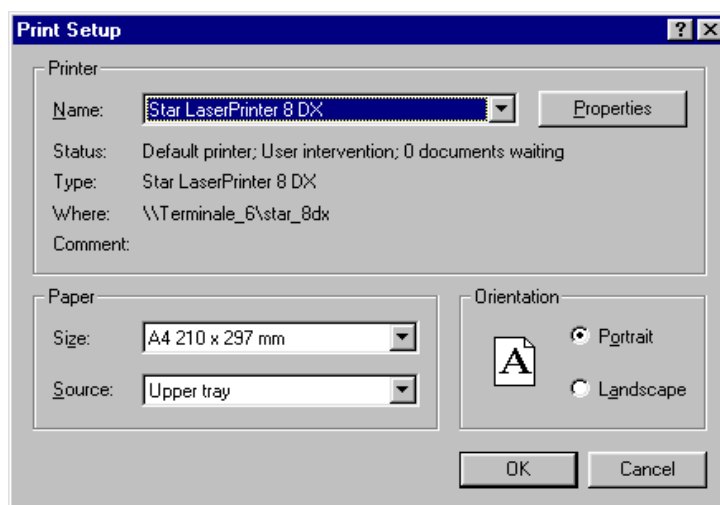

It allows to select among:

- one of the installed printers,
- the printer parameters; press  to access the dialogue window for settings of the selected printer,
- the paper: format and feeding of the printer,
- paper orientation.

6.2.12 EXIT - [Alt + F4]

To be used to exit from PqaSoft.

6.3 SETTING MENU

The items available in the Setting Menu are the following ones:



- T**rend - It displays the dialogue windows for diagram setting in the selected Trend page.
- P**anel - It displays the dialogue windows for the setting of the page containing fifteen indication panels. This option is activated only if the displayed page is the Panel page.
- H**armonics - It displays the dialogue windows for the setting of the full-scale representing the diagram of the harmonics. This option is activated only if the displayed page is the Samples & FFT page.
- A**nalysis - It allows to customise the recording file presentation.
- L**anguage - It allows to select the PqaSoft language.

6.3.1 TREND SETTING

This item is activated only if the displayed page is the Trend page.

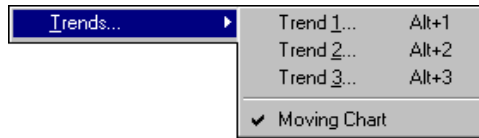

- Trend1** it activates the upper diagram setting.
- Trend2** it activates the middle diagram setting.
- Trend3** it activates the lower diagram setting.
- Moving Chart** it activates/deactivates the automatic diagram scrolling.

When you select **Trend1**, **Trend2** or **Trend3**, a dialogue window appears, in which for each of the five tracks of the diagram one variable measured by the connected instrument is displayed.

It is possible to access the same dialogue window directly from the Trend page, by means of the right button of the mouse, when the cursor is on the diagram to be set.

When you select **Moving Chart** it is possible to activate or deactivate the function allowing to display always the diagram for the whole period (at the end of the set period, the diagram moves in the window in order to display always the latest values acquired by the instrument).

As an alternative, the diagram, at the end of the set period, can be completely erased, to start again from the beginning.

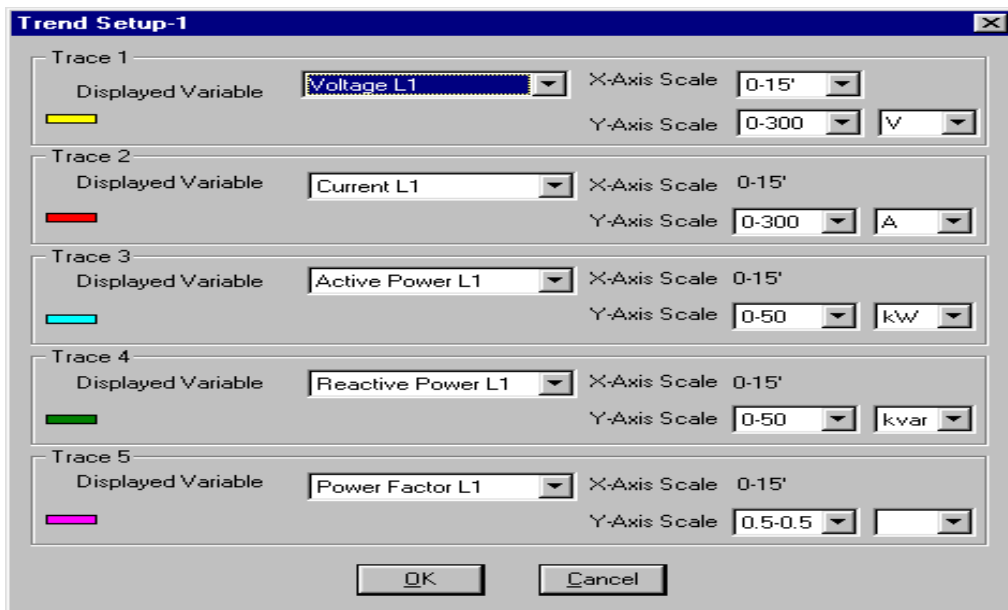

In the first roll-down window you can select the variable measured by the connected instrument to be associated to the tracks (1 to 5) of the diagram.

In the order, it's necessary to set the scale value on the X axis (Time scale); This scale is the same for all the 5 tracks of the diagrams.

Then, you should give a value to the Y scale; the user can set the scale and the measuring unit individually for each single variable represented. The measuring unit changes automatically according to the selected variable.

Once selected the variables for the five tracks of the trend diagrams, confirm your settings by means of the **OK** key.

Press **Cancel** to exit without confirming the changes.

6.3.2 PANEL SETTING - (Alt + P)

This item is activated only if the displayed page is the Panel page.

When you select this item, the following dialogue window appears, allowing to set the page containing the indication panels.

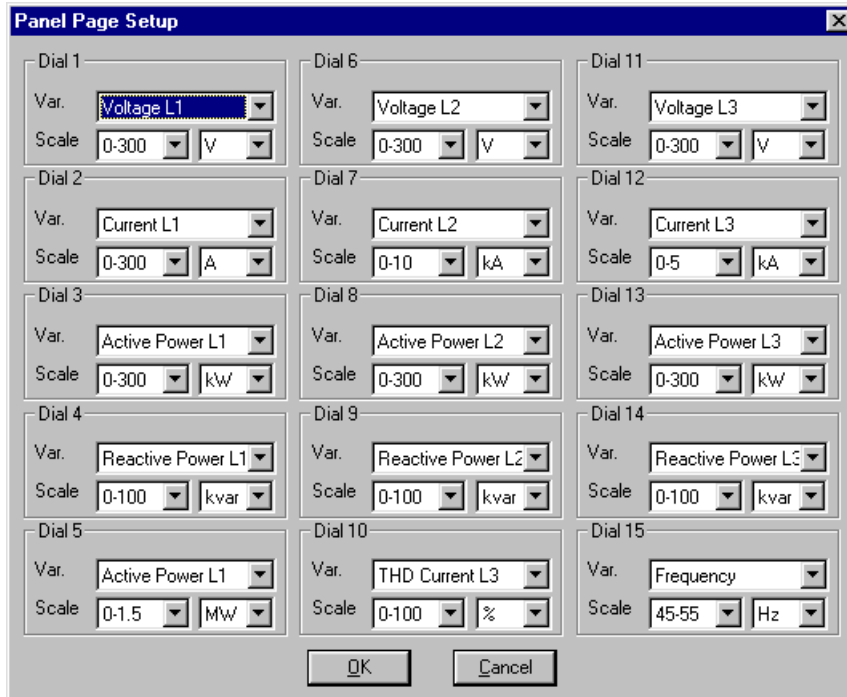

In the first roll-down window you can select the variable measured by the connected instrument to be associated to the indication instrument.

The second selectable parameter is the scale, that changes according to the selected variable. You can choose among different multiplication factors for the selected scale, by means of the roll-down window. The values of the full-scale are absolute. The user can know whether the indicated value is negative only by reading the value displayed in digital format in the upper part.

Press  to confirm the selections.

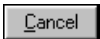
Press  to exit without confirming the selections.

It is possible to access the dialogue window to set the indication instruments individually directly from the Panel page, by means of the right button of the mouse, when the cursor is on the indicator to be set.

The following dialogue window is displayed:



The setting of each panel uses the same procedure of the page containing 15 instruments.

Press  to confirm the changes.

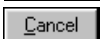
Press  to exit without confirming the changes.

6.3.3 HARMONICS SETTING - (Alt + H)

This item is activated only if the displayed page is the Samples & FFT page and it allows to set the full-scale of the three diagrams.

A dialogue window appears, where you can define the full-scale of the diagrams as a percentage value referred to the basic harmonic.

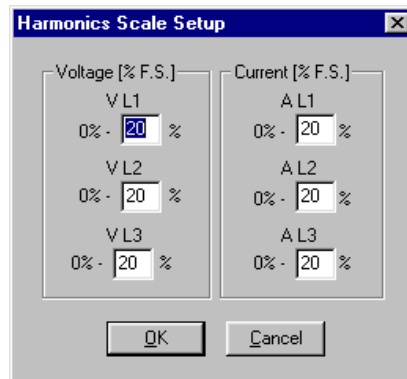

The user should set the percentage value, referred to the basic harmonic, of the maximum full-scale of the diagrams to be displayed.

The minimum full-scale value is fixed at 0 (zero) and it can not be changed by the user.

Press to confirm the changes.

Press to exit without confirming the changes.

6.3.4 ANALYSIS SETTING

The Analysis pages allow the study of the storages carried out by the instruments and downloaded on the PC. The commands are active only if the currently displayed page is the Analysis page and if one storage file is opened (see.chap.6.2.9).

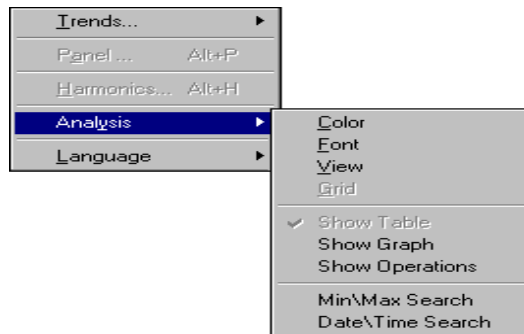

- **Colors** - it selects the colours used.
- **Font** ⁽¹⁾ - it changes the font used in the table.
- **View** - it selects the data to be displayed in the selected window.
- **Grid** ⁽²⁾ - it displays the dialogue windows allowing to display the grid and the position of labels on the time axis.
- **Show Table** - it displays the recording file as a table.
- **Show Graph** - it displays the recording file as a graph.
- **Show Operations** - it displays the analysis page of voltage faults.

- **Min/Max search** - it allows to search for the minimum or maximum value of the desired size in the displayed file.
- **Date/Time search** - it allows to search for the data according to the recording date.

Note: ⁽¹⁾ This menu is displayed only if the current page is in the "table" mode.

⁽²⁾ This menu is displayed only if the current page is in the "graph" mode.

6.3.4.1 COLORS SETTING

To be used to change the colors of the page.

The dialogue window appearing depends on the display mode of the recording file (as a Table or Graph).

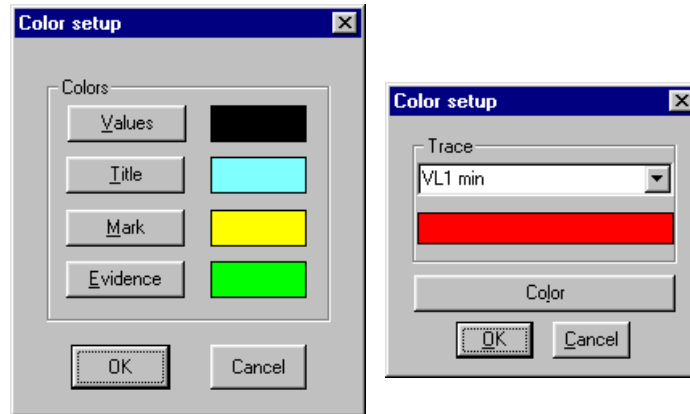

In the **Table** mode it is possible to select the text color, the title background, the background of the values selected with the mouse and the background of those highlighted with the **Display** option (see sect. 4.4.3). In the **Graph** mode it is possible to select the color associated to each track.

6.3.4.2 FONT SETTING

To be used to change the font used in the table.

When you select a new font, the page is updated; the scrolling bars, therefore, could change their look.

The standard window of Windows for font selection appears.

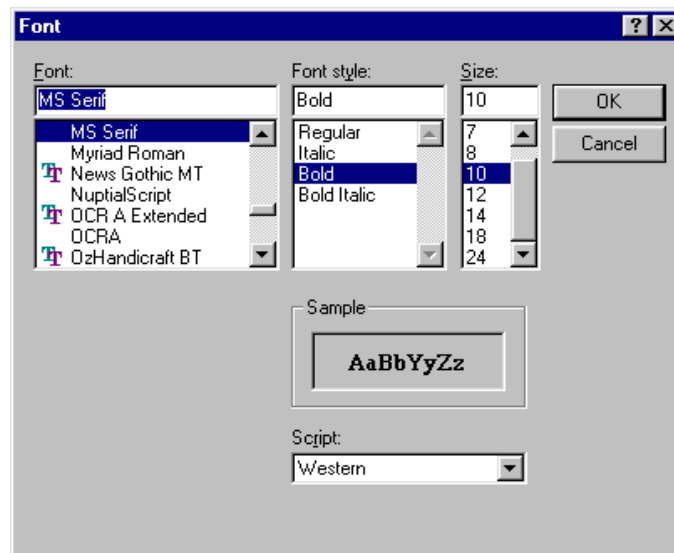

6.3.4.3 DISPLAY SETTING

To be used to change the display scale.

Furthermore, this item allows to highlight a period of time inside the record.

In case of **Graph** display mode, the following window appears:

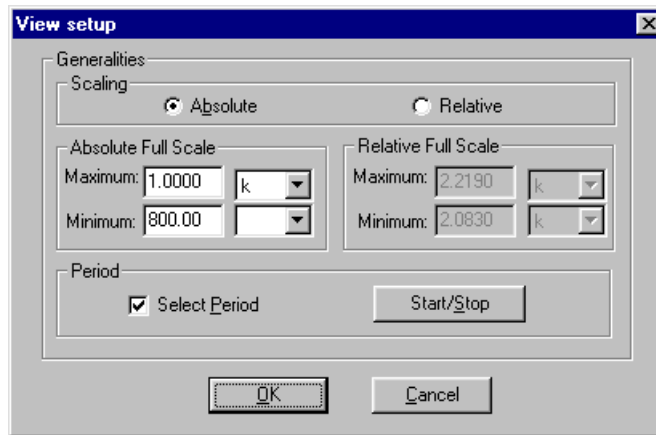

- **Scaling:** - it allows to select between the absolute and relative display mode.
- **Absolute F.S.:** - the selected size is displayed with a display range: zero - full scale value of the same measurement. The minimum and maximum display values can be changed.
- **Relative F.S.:** - the selected size is displayed with a display range: minimum-maximum of the measured value. The minimum and maximum display values can be changed.
- **Select. Period:** - it allows to define a period inside the entire record.

Press  to display the following dialogue window, allowing to select a time interval.

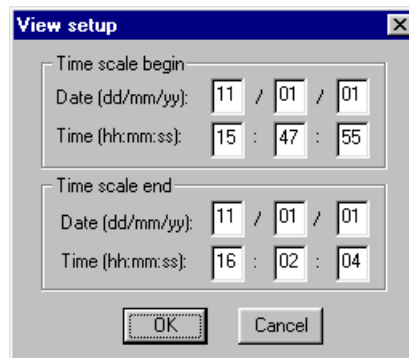

This window appears also in case of **Table** display mode.

6.3.4.4 GRID SETTING

To be used to change the grid in the diagram.

This item is not activated in case of **Table** mode.

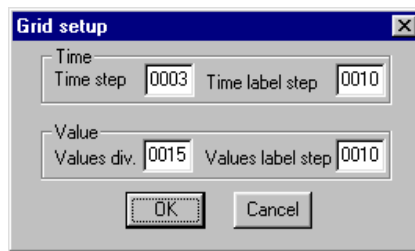

Time

- **Time step:**

it defines the amount of sampling in the file between one grid line and the following one (e.g.: 100 means that for every 100 values of the recording file, a vertical line is traced in the grid).

- **Time label step:**

it defines the interval of grid lines where the time values should be written (e.g.: 10 means that every 10 grid lines, the corresponding time is indicated).

Value

- **Value Div.:**

(*Value Divisions*) it defines how many parts the vertical scale should be divided into (e.g.: 10 means that the diagram should be divided in 10 equal parts).

- **Value label step:**

it defines the interval of grid lines where the values should be written (e.g.: 2 means that every 2 grid lines, the corresponding measure is indicated).

6.3.4.5 SHOW TABLE -

It allows to select the **Table** display mode of data contained in the file.

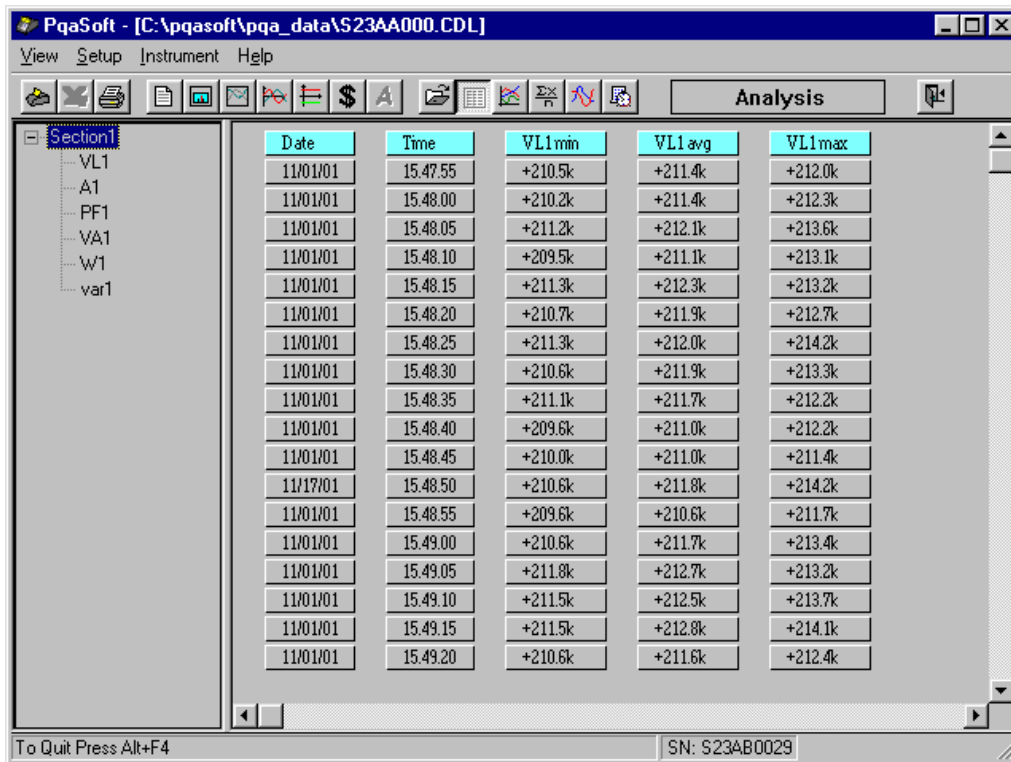

Date	Time	VL1min	VL1avg	VL1max
11/01/01	15.47.55	+210.5k	+211.4k	+212.0k
11/01/01	15.48.00	+210.2k	+211.4k	+212.3k
11/01/01	15.48.05	+211.2k	+212.1k	+213.6k
11/01/01	15.48.10	+209.5k	+211.1k	+213.1k
11/01/01	15.48.15	+211.3k	+212.3k	+213.2k
11/01/01	15.48.20	+210.7k	+211.9k	+212.7k
11/01/01	15.48.25	+211.3k	+212.0k	+214.2k
11/01/01	15.48.30	+210.6k	+211.9k	+213.3k
11/01/01	15.48.35	+211.1k	+211.7k	+212.2k
11/01/01	15.48.40	+209.6k	+211.0k	+212.2k
11/01/01	15.48.45	+210.0k	+211.0k	+211.4k
11/17/01	15.48.50	+210.6k	+211.8k	+214.2k
11/01/01	15.48.55	+209.6k	+210.6k	+211.7k
11/01/01	15.49.00	+210.6k	+211.7k	+213.4k
11/01/01	15.49.05	+211.8k	+212.7k	+213.2k
11/01/01	15.49.10	+211.5k	+212.5k	+213.7k
11/01/01	15.49.15	+211.5k	+212.8k	+214.1k
11/01/01	15.49.20	+210.6k	+211.6k	+212.4k

To display data hidden because of lack of space on the screen, move by means of the scrolling bar or select the desired data in the tree structure on the left part of the window. The example shows a recording file of MIN/AVG/MAX.

6.3.4.6 SHOW GRAPH -

It allows to select the **GRAPH** display mode of data contained in the file.

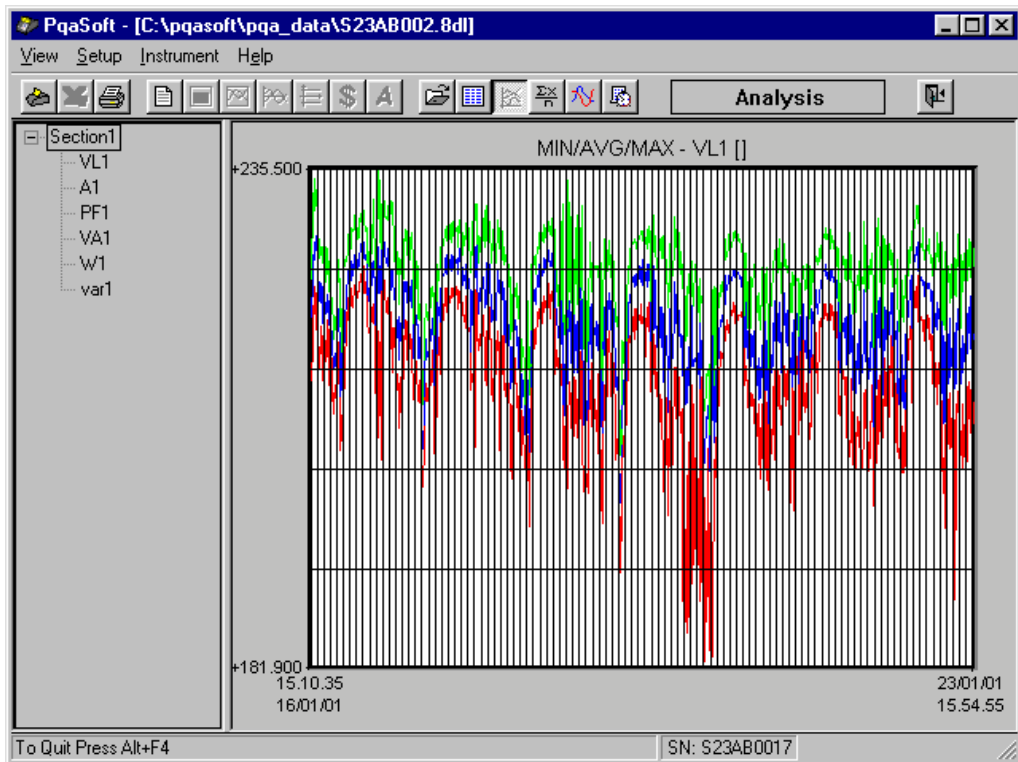

To display data hidden because of lack of space on the screen, select the desired data in the tree structure on the left part of the window. The example shows a recording file of MIN/AVG/MAX.

6.3.4.7 DISPLAY RECORDING ANALISYS -

Use this command to display the results of the analisys made on the stored data.

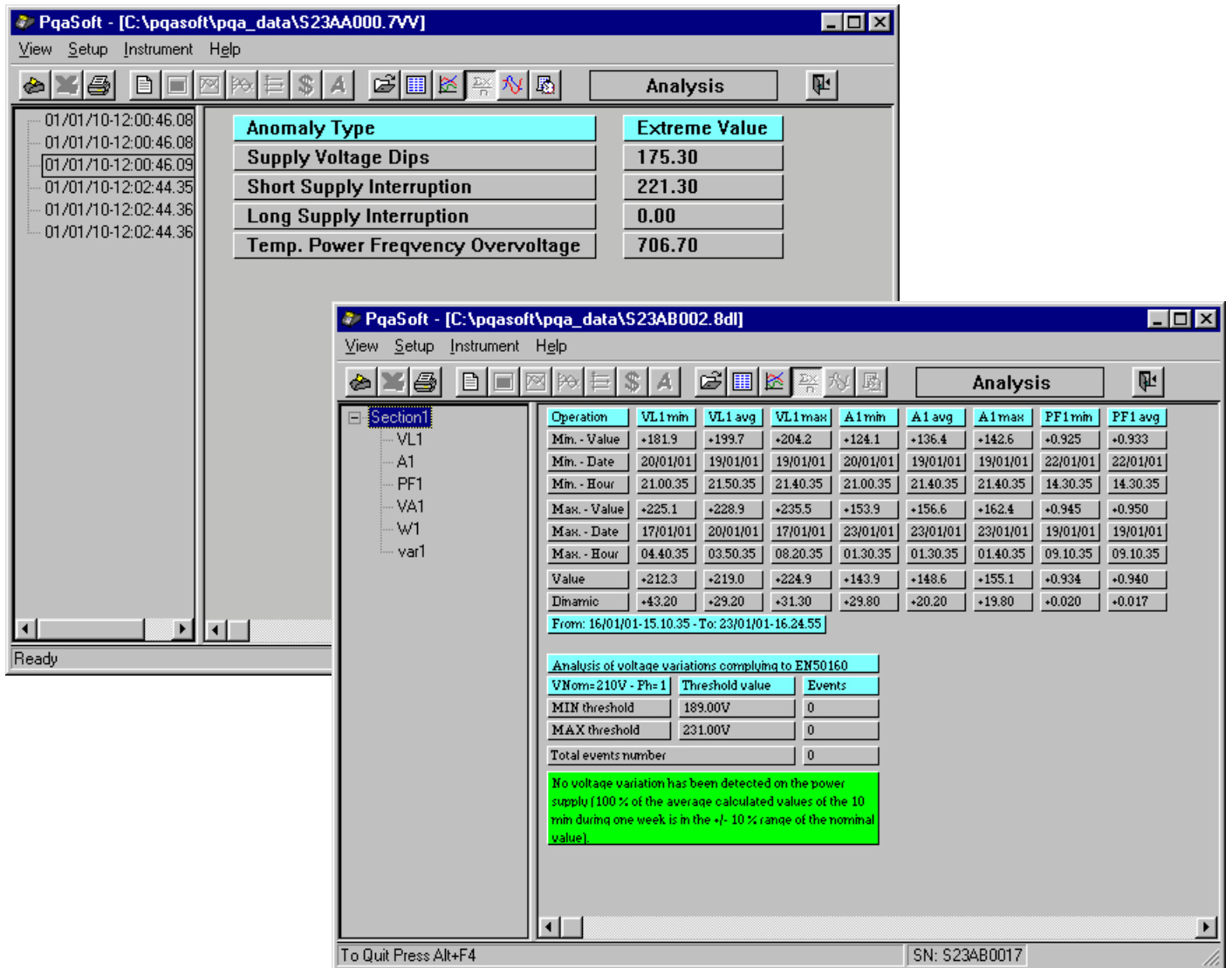

The instrument measures and stores different network faults; the software, after the download on the PC, analyzes and divides into categories complying with the EN50160 standard. The categories recognised by the software depend on the type of selcted storage:

Storage: Voltage dips:

- Voltage dips
- Short voltage fault
- Long voltage fault
- Temporary overvoltage

Storage: MIN/AVG/MAX

- Power supply variations

Power supply voltage variation

The study of this type of anomaly can be carried out complying with the standard only if the instrument has stored data for a whole week.

If the number of data is enough, pushing the analysis key  the windows for setting nominal value is displayed.

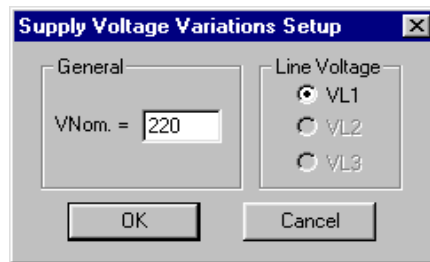

It is possible to study with another value for Vnom, by double clicking anywhere on the windows to let windows for setting appear again.

By scrolling vertically the windows for analysis it is possible to read the message containing the result of the study carried out:

- No anomalies:

No voltage variation has been detected on the power supply (99 % of the average calculated values of the 10 min during one week is in the +/- 10 % range of the nominal value).

- Anomaly:

A voltage variation has been detected on the power supply (only 12 % of the average calculated values of the 10 min during one week is in the +/- 10 % range of the nominal value).

- Insufficient number of data:

The number of stored voltage values is not enough to analyze the Supply voltage variations in compliance with EN50160

6.3.4.8 SEARCH FOR MIN/MAX -

To be used to search for the minimum or maximum value of the desired size, recorded by the instrument. When you select this item, the following dialogue window is displayed:

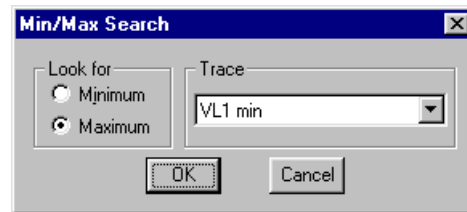

The dialog window allows to specify the type of value to be found out (min or max) and the trace where it should be searched (min = trace min. values, avg = trace av. values, max = trace max. values).

6.3.4.9 SEARCH FOR DATE/TIME -

To be used to search for a record, according to date and time. When you select this item, the following dialogue window is displayed:

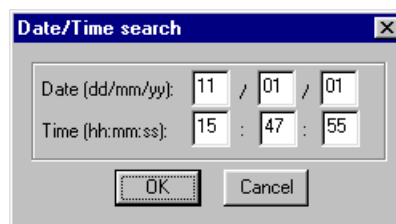

The user should enter the date in the Day Month Year format and the time in the Hour Minutes Seconds format.

Should the user enter an incorrect character or date, the field will be cancelled.

Should the search fail, the diagram or the table will display the first record stored in the file.

6.3.5 LANGUAGE SELECTION

To be used to change the program language.

This item is always activated and it allows to give the program one of the available languages.

The entire text of the program will be immediately displayed in the selected language.

6.4 INSTRUMENT MENU

The items of the Instrument Menu are the following:

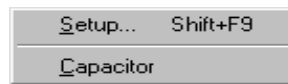

- **S**etup - It displays the dialogue window allowing to program the instrument connected to the PC.
- **C**apacitor - It displays the page with the calculation of the capacity of the power factor correction capacitors.

6.4.1 INSTRUMENT SETTING - [Shift + F9]

It displays a dialogue window allowing the user to set all parameters of the instrument connected to the P.C.

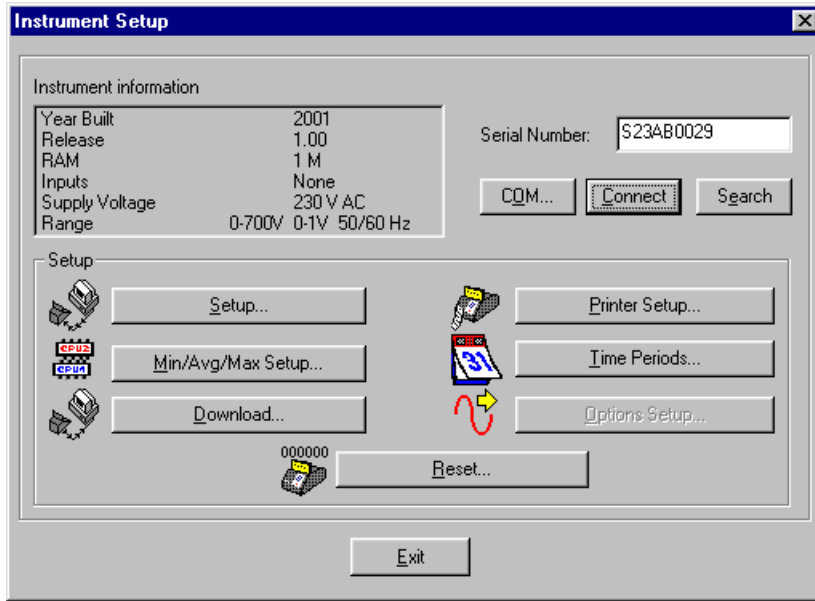

- **Instrument info:**

Information related to the connected instrument. The information about the connected instrument is the following: year of manufacture, firmware release, available RAM, available optional input, supply voltage and measuring range.

- **Serial number:**

The user should enter the serial number of the connected instrument to be examined in this field.



To access the dialogue window to set the parameters related to the serial port of the PC.



To examine the instrument bearing the indicated serial number.

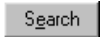

To search automatically for the Baud Rate of the connected instrument. The user should enter the serial number of the connected instrument, otherwise the search for the Baud Rate will fail.



To access the dialogue window to set the general parameters of the instrument. The button is activated only when the instrument is connected.

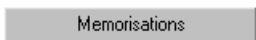

To access the dialogue window to set the read in. The button is activated only when the instrument is connected.



To access the dialogue window to transfer the stored values from the RAM of the connected instrument to the PC. The button is activated only when the instrument is connected.

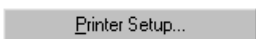

To access the dialogue window allowing to set the printer. The button is activated only when the instrument is connected.

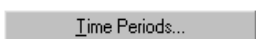

To access the dialogue window allowing to set the timeperiods. The button is activated only when the instrument is connected.

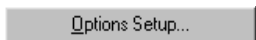

To access the dialogue window to set the analogue input. The button is activated only when the function is available.

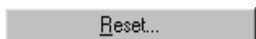

To access the dialogue window to reset the energy counters, the read in and the MIN/MAX page of PqaSoft.

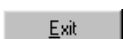

To exit from the dialogue page for the instrument setting.

6.4.1.1 DIALOGUE WINDOW OF THE SERIAL PORT

The **COM...** button is always activated and it allows to set all parameters related to the PC serial port; furthermore, it allows to enter the serial number of the connected instrument. Moreover, the **Search** button allows to search for the communication speed of the connected instrument.

The displayed dialogue window is the following one:

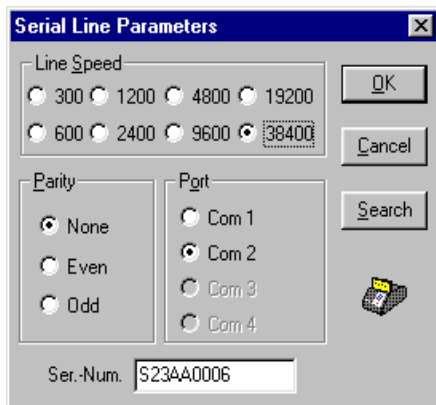

- Line speed:** It can be selected among 300, 600, 1200, 2400, 4800, 9600, 19200 or 38400 baud. The default value is 9600 baud.
- Parity:** It selects the parity: "None", "Even", "Odd". The default value is "None".
- Port:** It selects the communication port for the instrument connection.
- Ser. Num.:** The user should set the serial number of the connected instrument. The **PqaSoft** program can read the serial number to acknowledge the options of the instrument and to self-configure.

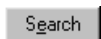

It searches automatically for the Baud Rate of the connected instrument. **The user should set the serial number of the connected instrument, otherwise the search for the Baud Rate will fail.**

After confirming with **OK** , the following dialogue window appears until the instrument has been connected:

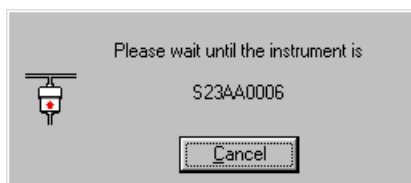

With **Cerca**, PqaSoft tries to connect the instrument to the PC using all the Baud Rates. The following dialogue window shows a few trials:

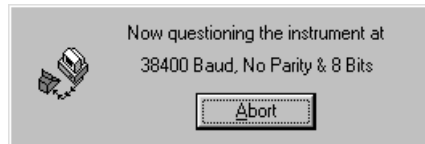

In case the connection of the instrument has been impossible, after a few seconds the following window is displayed:

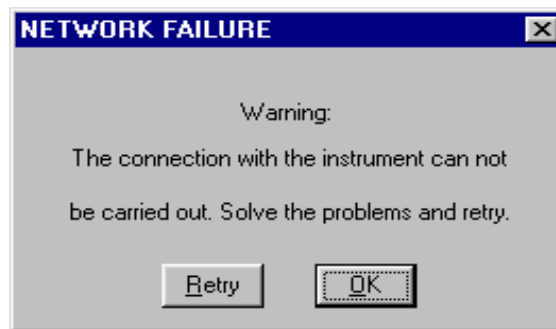

PqaSoft carries out 3 subsequent trials of connection and the waiting time depends on the communication speed.

In this case, check that the PQA700 has been switched on and that the serial cable has been connected.

Warning: the window "network failure" is displayed when the connection between instrument and PC brakes down, too. The interruption can occur due to the switch off or to the modification from the instrument keyboard of communication speed. In the latter case it is necessary to establish the connection again, by setting the communication speed of the software manually or automatically by the key **Cerca**.

6.4.1.2 DIALOGUE WINDOW OF PROGRAMMABLE PARAMETERS

The  button is activated when the instrument is connected and it allows to set the main parameters of the connected instrument.

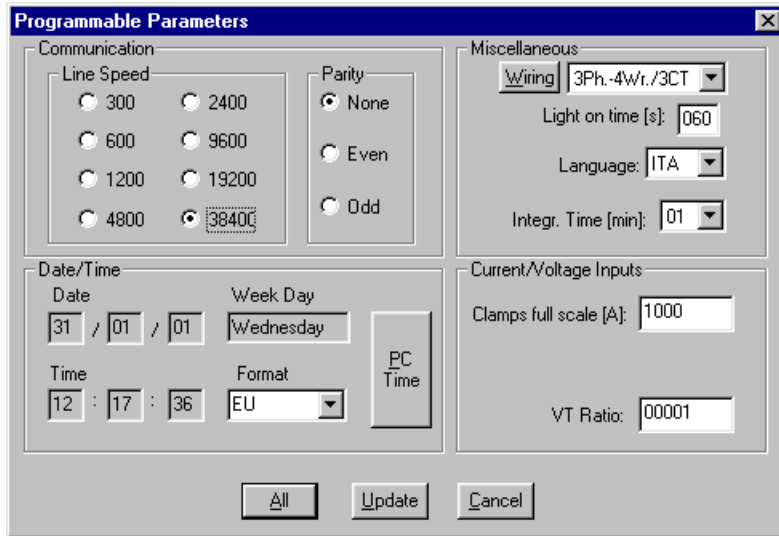

Line speed: The user can select the serial communication speed of the connected instrument. PqaSoft automatically updates the serial communication parameters of the PC.

Parity: The user can select the kind of parity control of the serial line of the connected instrument among None, Even and Odd. PqaSoft automatically updates the serial communication parameters of the PC.

Date/Time: The user can set the date and time of the connected instrument. In the window, the date, time and day of the week are displayed, as read by the connected instrument; it is also possible to select the display format of the instrument between European and American.



When you select this button, PqaSoft transmits directly the date and time of the PC to the connected instrument.

Connection: Type of connection (quantity of phases and connected cables).



It displays the connection diagram of the selected connection.

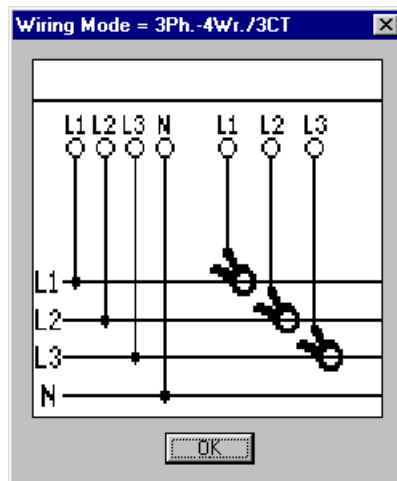

- Light on time [s]:** The user can determine the switching on time (in seconds) of the back light of the display.
- Language:** The user can select the language of the text displayed by the instrument among those supported by the instrument itself.
- Integr. Time:** The user can set the integration time (in minutes) to calculate the average power.
- Clamp full scale [A]:** The user can set the full-scale value (in Ampere) of the clamp used to measure the current (max 3000A).
- VT ratio:** The user can set the ratio of transformation of the voltage input.

You can select to set all the parameters of the connected instrument with the displayed values, or to set only those parameters that have been changed.



All parameters of the dialogue window are transferred to the instrument.



Only the modified items of the dialogue window are updated on the instrument.



The dialogue window is closed without changing the instrument setting.

Press  or  to display a dialogue window indicating the status of the data transfer.

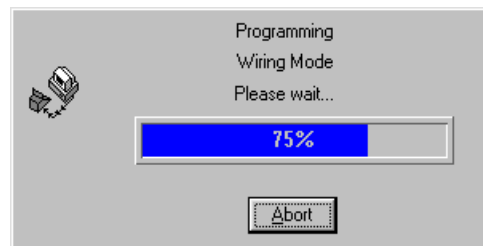

6.4.1.3 STORAGE SETTING WINDOW

The **Memorisations** button is activated when the instrument is connected; when the instrument is set for a recording, this button becomes **Voltage Dips Setup...** or **Min/Avg/Max Setup...**, according to the kind of set recording.

While PqaSoft examines the instrument, the following message is displayed:

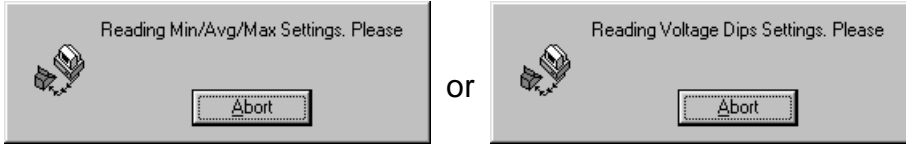

Then, the setting page appears.

Storage of Voltage dips:

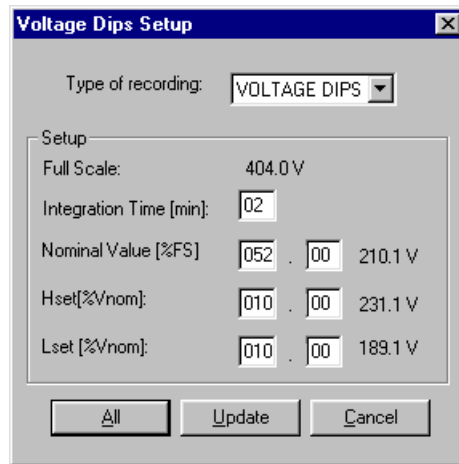

- Type of recording:** It can be selected among Voltage dips, MIN/AVG/MAX and None.
- Integration Time:** It sets the integration time in seconds, for the re-calculation of the reference voltage.
- Nominal value [%FS]:** Rated value of voltage, expressed as a percentage referred to the 404V_{L-N} full-scale. At the right side of this value, the real calculated value is displayed.
- H set [%Vnom]:** Value over which the overvoltage is recorded. This value is expressed as a percentage variation referred to the rated value (from + 1% to + 99%). At the right side of this value, the real calculated value is displayed.
- L set [%Vnom]:** Value below which the voltage dips or the mains interruption are recorded. This value is expressed as a percentage variation referred to the rated value (from - 1% to - 99%). At the right side of this value, the real calculated value is displayed.

MIN/AVG/MAX STORAGE:

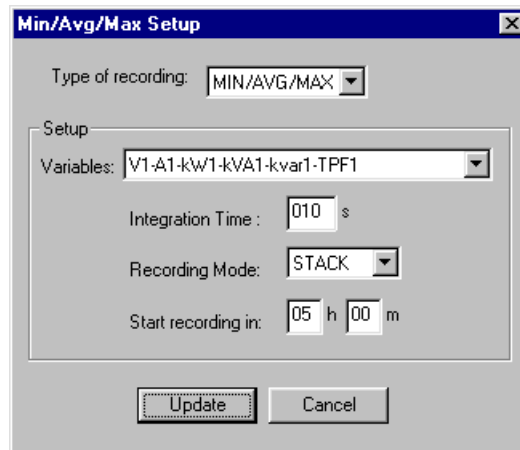

- Type of recording:** It can be selected among Voltage dips, MIN/AVG/MAX and none.
- Variables:** It selects the sizes to be stored among the possible selections.
- Integration time:** It sets the integration time in seconds, for the calculation of the AVG value.
- Recording mode:** It selects the managing mode of storage in RAM of the MIN/AVG/MAX values between: FIFO (storage of the latest data acquired by overwriting the oldest ones); STACK (storage of the data till the complete filling of the RAM).
- Start recording in:** Delay of storage beginning expressed in hours and minutes. The range can be set between 00:00 and 23:59. The parameter is important when the STACK storage mode is selected.

Should the kind of recording be changed, PqaSoft will show the following dialogue windows before cancelling the record in progress.

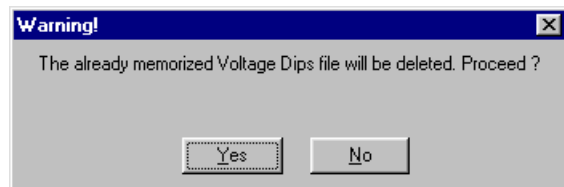
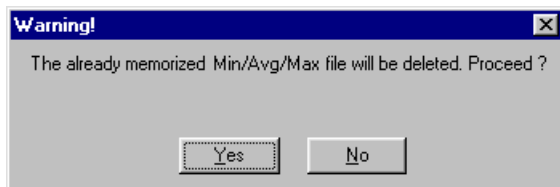

6.4.1.4 DOWNLOAD TRANSFER WINDOW

The  button is activated when the instrument is connected and it allows to transfer the data recorded by the instrument to the PC.

While PqaSoft examines the instrument, the following message is displayed:



During the transfer of data, the following dialogue window appears, indicating the progress.

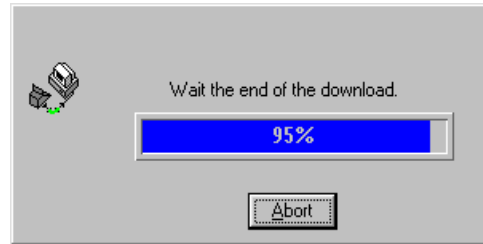

Upon completion, the dialogue window for the selection of the file name appears.

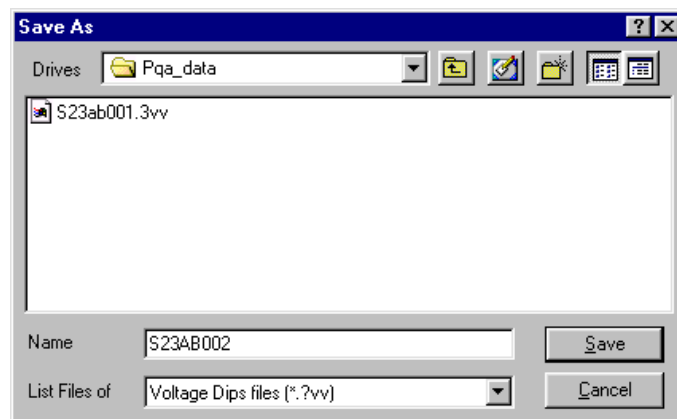

The name suggested to save the file consists of the first 8 digits of the serial number of the connected instrument. Anyway, it's possible to give the file another name.

The file extension consists in the ninth digit of the instrument serial number, plus **VV** in case of voltage dips transfer, or **DL** in case of MIN/AVG/MAX transfer. All files are in ASCII format.

Upon completion of the transfer, PqaSoft will show the request for cancelling of the just transferred data from the instrument.

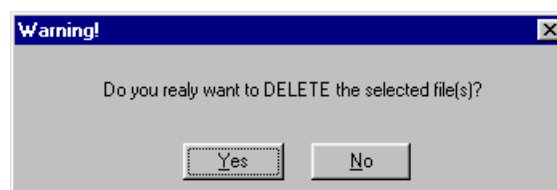

6.4.1.5 PRINT SETTING WINDOW

The  button is activated when the instrument is connected and it allows to set the automatic print.

The following window for print setting appears.

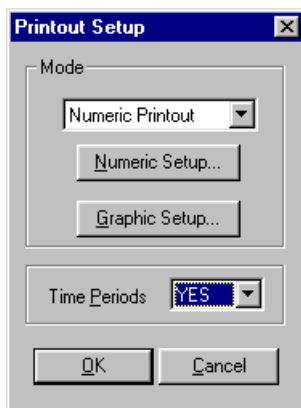

- Mode:** The user, by means of Combo Box, can select the kind of print among Numeric, Graphic and None.
- Time Periods:** The user can activate the automatic print of the daily energy counters divided into timeperiods at 24:00.

With **Numeric Setup / Graphic Setup**, one of the following dialogue windows for graphic print setting will be displayed:

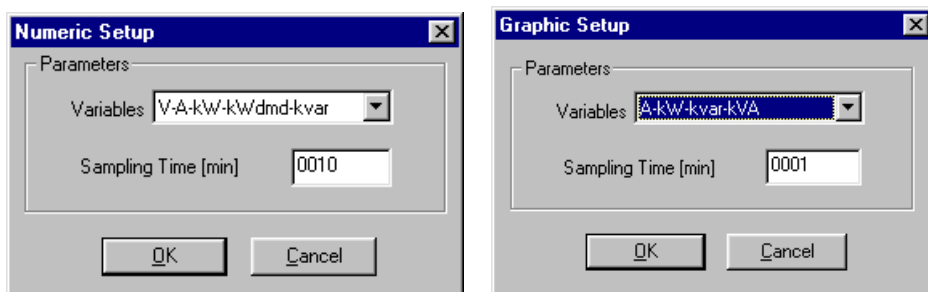

- Variable:** It selects the variables, the measurement carried out of which will be printed. You should select it among the available selections.
- Sampling time:** It selects the sampling time in minutes.

6.4.1.6 TIMEPERIODS SETTING WINDOW

The  button is activated when the instrument is connected and it allows to set the hours for the daily subdivision of energy consumption. It is possible to set up to 10 periods in one year, with changes of tariffs different among each other. For each period it's possible to set up to 8 different changes of tariffs during one day; up to three different tariffs can be set.

While PqaSoft examines the instrument, the following message is displayed:

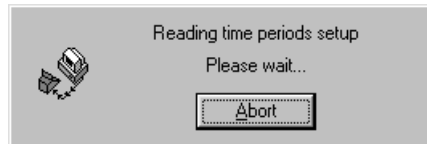

Then, the timeperiods setting page is displayed.

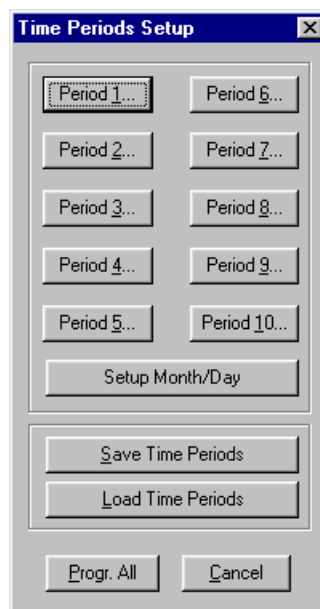

- Period 1 - 10:** It sets the changes of hours of the selected period.
- Month/Day:** It allows to associate the desired day/month of the year to one of the set periods.
- Save Time Periods:** It saves the time periods set in the instrument into a recallable profile (file *Tb_Templ.dat*).
- Load Time Periods:** It loads the stored time periods into a profile.

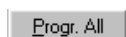

It sets all the time periods in the instrument.

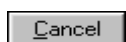

It exits from the time periods setting without setting the instrument.

It is possible to define the beginning (hours/minutes) of each tariff hour of the day. The user can enter up to 8 hour changes for one day.

It is possible to set three different tariffs (T1, T2, T3).

You should select the "T0" tariff to end the daily setting; the values indicated in the lines following the one containing the T0 tariff will not be acknowledged.

The example shows the M.T. Multihour tariff in force in Italy at printing time.

Setup Period 1

Time 1: 00 : 01 T3

Time 2: 08 : 00 T2

Time 3: 10 : 00 T1

Time 4: 12 : 00 T2

Time 5: 13 : 00 T1

Time 6: 18 : 00 T2

Time 7: 22 : 00 T3

Time 8: 24 : 00 T0

Setup Month/Day

OK Cancel

Setup Period 2

Time 1: 00 : 00 T3

Time 2: 06 : 30 T2

Time 3: 08 : 30 T1

Time 4: 12 : 00 T2

Time 5: 21 : 30 T3

Time 6: 24 : 00 T0

Time 7: 00 : 00 T0

Time 8: 00 : 00 T0

Setup Month/Day

OK Cancel

Then, the user can associate each day of the month to the just set tariff period (model of day). You should indicate the number of the period in the table (in the example period 1 has been associated to all the working days of January, February, March, October, November and December).

	Jan	Feb	Mar	Apr	May	Jun	Jul	Aug	Sep	Oct	Nov	Dec
Monday	1	1	1	2	0	2	0	0	2	1	1	1
Tuesday	1	1	1	2	0	2	0	0	2	1	1	1
Wednesday	1	1	1	2	2	2	0	0	2	1	1	1
Thursday	1	1	1	2	2	2	0	0	2	1	1	1
Friday	1	1	1	2	2	2	0	0	2	1	1	1
Saturday	0	0	1	2	2	2	0	0	2	0	0	0
Sunday	0	0	0	0	0	0	0	0	0	0	0	0

OK Cancel

The following dialogue window allows to save the profile just set in the instrument into a file. This function has been developed to facilitate the operator during the setting, as the timeperiods setting involves the setting of a large amount of data and because, generally, the setting requirements are limited to a few units, being always the same. This window offers the opportunity to add a new profile or to cancel an existing one.

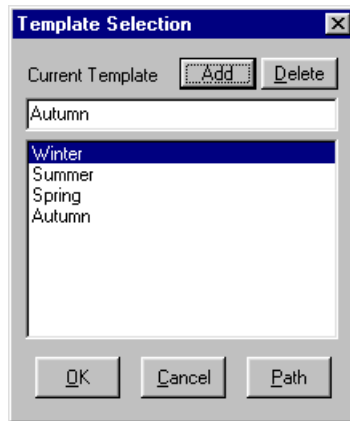

The following dialogue window allows to select the desired profile for the following setting of the instrument. Furthermore, it allows to accelerate the setting process of the instrument. This function has been developed to prevent the operator from setting at every time a large amount of data.

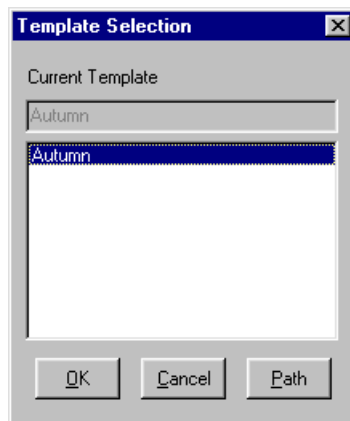

6.4.1.7 OPTIONS SETTING WINDOW

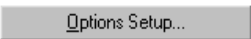
The  button is not available at the moment.

6.4.1.8 RESET WINDOW

The  button is activated when the instrument is connected and it allows to reset the energy counters, the RAM read in and the MIN/MAX page of PqaSoft.

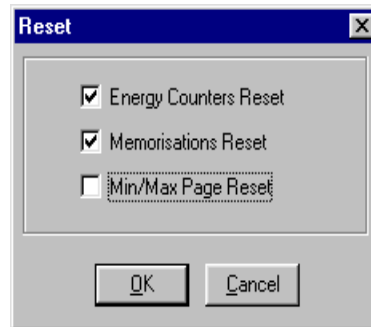

Energy Counters Reset:

At any time the user can reset the content of the energy counters and the counters divided into time periods.

Memorisations Reset:

At any time the user can reset the content of stored data carried out by the instrument.

Min/Max Page Reset:

At any time the user can reset all the minimum and maximum values indicated in the MIN/MAX display page of PqaSoft.

6.4.2 POWER FACTOR CORRECTION CAPACITORS

This item displays the dialogue window allowing to determine the capacity of the power factor correction capacitors.



When you select among the desired DPF ($\cos\phi$) available values (Target), on the right side of the window the reactive powers of power factor correction capacitors related to the single tri-phase lines, necessary to restore the values within the set limits, are displayed.

