

Power analyzers and Energy Meters

Compact Power Transducer

Type CPT-DIN "Advanced version"

CARLO GAVAZZI



- 2 digital outputs
- 16 freely configurable alarms with OR/AND logic linkable to up to 2 digital outputs
- RS422/485/RS232 serial output (MODBUS-RTU), iFIX SCADA compatibility

- Class 1 (kWh), Class 2 (kvarh)
- Accuracy ± 0.5 F.S. (current/voltage)
- Compact power transducer
- Instantaneous variables data format: 4 DGT
- Energies data format: 8+1 DGT
- System variables and phase measurements: V_{LL} , V_{LN} , A , A_{max} , A_n , A_{dmd} , $A_{dmd\ max}$, VA , VA_{dmd} , $VA_{dmd\ max}$, W , W_{dmd} , $W_{dmd\ max}$, W_{L1} - W_{L2} - W_{L3} max, var, PF, PF_{L1} - PF_{L2} - PF_{L3} min, Hz, ASY
- Four quadrant power measurement
- Energy measurements: total and partial kWh and kvarh (according to EN62053-21 and EN62053-23)
- Hour counter (5+2 DGT)
- TRMS meas. of distorted sine waves (voltages/currents)
- Universal power supply: 90 to 260 VAC/DC, 18 to 60 VAC/DC
- Dimensions: 45x83.5x98.5mm
- Voltage asymmetry, phase sequence, phase loss control
- Up to 3 analogue outputs (20mA or 10VDC)

Product Description

3-phase compact power transducer. Particularly recommended for the measurement of the main electrical variables also on board of machines. Housing for DIN-rail mount-

ing, with up to 3 analogue outputs, or RS485 communication port or alarm outputs or "Dupline" bus. Parameters programmable by means of CptASoft.

How to order CPT-DIN AV5 3 H XX AX



How to order CptASoft-kit

CptASoft: software to program the working parameters of the transducer and to read the energies and the instantaneous variables. The kit includes the communication cable.

Type Selection

Range codes	System	Outputs	Options
AV5: 400/690V _{LL} /1/5(6)AAC V _{L-N} : 185 V to 460 V V _{L-L} : 320 V to 800 V AV6: 120/208V _{LL} /1/5(6)AAC V _{L-N} : 45 V to 145 V V _{L-L} : 78 V to 250 V Phase current: 0.01A to 6A Neutral current: 0.05A to 6A	3 : 1-2-3-phase, balanced/unbalanced load, with or without neutral 1 : 1-3-phase, balanced load (*)	R2: 2-relay outputs O2: 2-open collector outputs A1: 1-analogue output: 0/4 to 20mA DC A3: 3-analogue outputs: 0/4 to 20mA DC V1: 1-analogue output: 0 to 10V DC V3: 3-analogue outputs: 0 to 10V DC S1: RS485/RS422 port S2: RS232 port DB: Dupline bus	AX: advanced functions Power supply L: 18 to 60 VAC/VDC H: 90 to 260 VAC/VDC

(*) Pay attention: the 3-phase balanced load measurement requires the connection of the neutral according to fig. 15 and 16 in the final part of this document.

Input specifications

Rated inputs	System type	Active and Apparent power, Reactive power	Accuracy
Current	3 (internal current transformers)	Range accuracy: 0.05I _n to I _{max}	$\pm(1.5\%RDG+3DGT)$ $\pm(3\%RDG+3DGT)$
Voltage	4	Current	$\pm(0.5\%RDG+2DGT)$ $\pm(1\%RDG+3DGT)$
Accuracy (RS485) (@25°C $\pm 5^\circ C$, R.H. $\leq 60\%$)	I _{max} : 6A, V _{max} : 400V _{LN} (690V _{LL}), I _n : 5A, V _n : 230V _{LN} (400V _{LL}) CT: 1, VT (PT): 1	Neutral current	$\pm(0.5\%RDG+2DGT)$ $\pm(1\%RDG+3DGT)$
Range accuracy: 0.02I _n to 0.05I _n		Phase-phase voltage	$\pm(0.5\%RDG+2DGT)$ $\pm(1\%RDG+3DGT)$
Current	$\pm(0.5\%FS)$ or $\pm(1\%RDG+2DGT)$	Phase-neutral voltage	$\pm(0.5\%RDG+2DGT)$ $\pm(1\%RDG+3DGT)$
Neutral current	$\pm(2\%RDG+3DGT)$	Active and Apparent power, Reactive power	$\pm(1\%RDG+3DGT)$ $\pm(2\%RDG+3DGT)$
Phase-phase voltage	$\pm(0.5\%RDG+2DGT)$	Active energy	Class 2 according to EN62053-21 (I start up: 10mA)
Phase-neutral voltage	$\pm(0.5\%RDG+2DGT)$		



Input specifications (cont.)

Reactive energy	Class 3 according to EN62053-23 (I start up: 10mA)	Measurements	Current, voltage, power, power factor, frequency TRMS measurement of distorted waves. Direct < 3, max 10A peak
Frequency	±0.1Hz (48 to 62Hz)		
Additional errors		Type	
Humidity	≤0.3% FS, 60% to 90% RH	Coupling type	
Temperature drift	≤ 200ppm/°C	Crest factor	
Sampling rate	1600 samples/s @ 50Hz 1900 samples/s @ 60Hz	Input impedance	
Display refresh time	200ms	400/690V _{L-L} (AV5)	1.6 MΩ ±5%
Measurement format	(serial communication)	120/208V _{L-L} (AV6)	1.6 MΩ ±5%
Instantaneous variables	4 DGT, max indication 9999	Current	≤ 0.01Ω
Energies	8+1 DGT, max indication 999 999 99.9	Frequency	48 to 62 Hz
Hourcounter	5+2 DGT, max indication 9 999 9.99	Overload protection	(max values)
		Continuos voltage/current	AV5: 460V _{LN} /800V _{LL} /6A AV6: 145V _{LN} /250V _{LL} /6A
		For 500ms: voltage/current	AV5: 800V _{LN} /1380V _{LL} /36A AV6: 240V _{LN} /416V _{LL} /36A

Output Specifications

Analogue Outputs			(see the table "List of the variables that can be connected to")
Number of outputs	Up to 3	Set-point adjustment	From 0 to 100% of the retransmitted scale
Accuracy (@ 25°C ±5°C, R.H. ≤60%)	±0.3% FS	Hysteresis	from 0 to full scale
Range	0 to 20mA or 0 to 10 VDC	On-time delay	0 to 255s
Scaling factor:	Programmable within the whole range of retransmission; it allows the retransmission management of all values from: 0 and 20 mA, 0 and 10VDC	Output status	Selectable; normally de-energized and normally energized
Response time	≤ 400 ms typical (filter excluded)	Min. response time	≤400ms, filters excluded, Set-point on-time delay: "0 s"
Ripple	≤ 1%, according to IEC 60688-1, EN 60688-1	Note	The 2 digital outputs can also work as one pulse output and one alarm output.
Total temperature drift	≤ 500 ppm/°C	Static outputs	
Load: 20 mADC	≤ 350 Ω	Purpose	For alarm outputs or for pulse outputs
10 VDC	≥ 10KΩ	Signal	V _{ON} 1.2 VDC/ max. 100 mA V _{OFF} 30 VDC max.
Insulation	By means of optocouplers, See table "Insulation between inputs and outputs"	Insulation	By means of optocouplers, See table "Insulation between inputs and outputs"
Digital outputs		Relay outputs	
Pulse		Purpose	For alarm outputs or for pulse outputs
Number of outputs	Up to 2	Type	Relay, SPST type AC 1-5A @ 250VAC DC 12-5A @ 24VDC AC 15-1.5A @ 250VAC DC 13-1.5A @ 24VDC
Type	Programmable from 0.01 to 500 pulses per kWh/kvarh (total and partial) Outputs connectable to the total and/or partial energy meters (Wh/varh)	Insulation	See table "Insulation between inputs and outputs"
Pulse duration	≥ 100ms <120msec (ON), ≥ 120ms (OFF) according to EN62053-31		
Alarm			
Number of outputs	up to 2, independent		
Alarm modes	Up alarm, down alarm, down alarm, in window alarm, out window alarm. Start-up deactivation function at power-on for all kinds of alarm. All of them connectable to all variables		



Output Specifications (cont.)

RS422/RS485	(on request) Multidrop bidirectional (static and dynamic variables) 2 or 4 wires, max. distance 1200m, termination directly on the instrument		between inputs and outputs”
Connections	From 1 to 255, selectable via software	RS232 Type Connections Address Protocol Baud-rate	Halfduplex communication Point to point connection 3-wire, max. distance 15m 1 to 255 selectable via software MODBUS/JBUS (RTU) 4800, 9600, 19200, 38400 bits/s other characteristics like R422/RS485 port
Addresses	System and phase variables: see table “List of variables...” All the configuration parameters.	Dupline Bus Address Variables	Full Dupline compatibility Programmable using CptASoft kWh, kvarh + 8 variables chosen among the available ones. By means of optocouplers. See table “Insulation between inputs and outputs”
Protocol	1 start bit, 8 data bit, no parity, 1 stop bit	Insulation	
Data (bidirectional) Dynamic (reading only)	4800, 9600, 19200, 38400 bits/s		
Static (writing only)	By means of optocouplers, See table “Insulation		
Data format			
Baud-rate			
Insulation			

RS232 Configuration Bus

Connections	RJ45 (3-wire) for special cable	Insulation	By means of optocouplers, See table “Insulation between inputs and outputs”
Baud-rate	4800 bits/s		
Data format	1 start bit, 8 data bit, no parity, 1 stop bit		

CptASoft software: parameter programming and data reading

CptASoft	Multi language software to program the working parameters of the transducer and to read the energies and the instantaneous variables. Compatibility with Windows 95/98/98SE/2000/XP.		Filtering parameters Alarm variables Alarm set-points and relevant parameters Variable to be connected to the analogue outputs Scaling of analogue outputs Energies to be connected to the pulse outputs Parameters related to the pulse outputs Reset function: max/min values, energies, dmd
Working mode	Two different working modes can be selected: - management of a local RS485 network; - management of the communication from single instrument to PC (RS232);	Data access	By means of RS232 serial port, RS485 serial port or RS232 configuration port (RJ45)
Programming parameters	System selection: 1-2-3 phases CT/VT ratios		

Software functions

System selection System 3, unbalanced	3-phase (3-wire, 4-wire) 3-phase ARON 2-phase (3-wire)	Transformer ratio CT VT (PT)	1 to 60 000 1.0 to 6 000.0
System 3, balanced	1-phase (2-wire) 3-phase (3-wire, 4-wire) 3-phase (3-wire) “1CT+1VT” 3-phase (3-wire) “1CT+3VT”	Filter Operating range	0 to 100% of the retransmitted scale
System 1, balanced	3-phase (4-wire) “1CT+1VT” 3-phase (4-wire), phase to neutral voltage measurement 1-phase (2-wire)	Filtering coefficient Filter action	1 to 32 Measurements, alarms, serial output (fundamental variables: V, A, W and their derived ones).



Software functions (cont.)

Alarms Working mode	"OR" or "AND" or "OR+AND" functions (see "Alarm parameter and logic" page). The user can freely program up to 16 total alarms. (out1+out2). The alarms can be connected to any variables available in the table "List of the variables that can be connected to"	- W dmd max, VA dmd max, A ₁ max, A ₂ max, A ₃ max, W _{L1} max, W _{L2} max, W _{L3} max, W sys max, A ₁ dmd max, A ₂ dmd max, A ₃ dmd max, VA sys dmd max, W sys dmd max, cosφ ₁ min, cosφ ₂ min, cosφ ₃ min - all the counters: total kWh, partial kWh, total kvarh, partial kvarh, hour counters - reset of all the above mentioned variables in a single command
Reset	The following resets are available by means of the configuration software: - all the maximum/min values:	

Power Supply Specifications

AC/DC voltage	90 to 260VAC/DC 18 to 60VAC/DC	Power consumption	AC: 2.5 VA DC: 2W
----------------------	-----------------------------------	--------------------------	----------------------

General Specifications

Front LED's Power on Diagnostics RS485/RS422/RS232 Dupline bus Alarm outputs Pulse outputs Analogue outputs	Green TX data (Green) RX data (Red) TX data (Green) RX data (Red) 1st output activation (Green) 2nd output activation (Red) 1st output activation (Green) 2nd output activation (Red) Output signal within the programmed scale (Green) Output signal exceeding 110% of full scale (Red)	4kVAC _{RMS} between power supply and RS485/RS232/programming port (RJ45)
Operating temperature	0° to +50°C (32° to 122°F) (RH < 90% non condensing)	Dielectric strength
Storage temperature	-10° to +60°C (14° to 140°F) (RH < 90% non condensing)	EMC
Overvoltage category	Cat. III (IEC 60664, EN60664)	Emissions Immunity
Insulation (for 1 minute)	4kVAC _{RMS} between measuring inputs and power supply. 4kVAC/DC @ I _g 3mA between measuring inputs and RS485/RS232/programming port (RJ45)	Pulse voltage (1.2/50μs)
		Safety standards
		Mesurement standards
		Approvals
		Connections 5(6) A Max cable cross sect. area
		Housing Dimensions (WxHxD) Material
		Mounting
		Protection degree
		Weight

List of the variables that can be connected to:

- RS485/RS422/RS232 communication port
- Analogue outputs (“max” variables and “energies” excluded)
- Alarm outputs (“max” variables”, “energies” and “hour counter” excluded)
- Pulse outputs (only “energies”)
- Dupline bus (only “total energies” + up to 8 selectable variables)

No	Variable	1-phase system	2-phase system	3-ph. 4-wire balanced sys.	3-ph. 4-wire unbal. sys.	3-ph. 3-wire bal. sys.	3-ph. 3-wire unbal. sys.	Notes
1	V L1	x	x	x	x	o	o	
2	V L2	o	x	x	x	o	o	
3	V L3	o	o	x	x	o	o	
4	V L-N sys	o	x	x	x	o	o	Sys = system
5	V L1-2	o	x	x	x	x	x	
6	V L2-3	o	x	x	x	x	x	
7	V L3-1	o	o	x	x	x	x	
8	V L-L sys	o	x	x	x	x	x	Sys = system
9	A L1	x	x	x	x	x	x	◆
10	A L2	o	x	x	x	x	x	◆
11	A L3	o	o	x	x	x	x	◆
12	Amax	x	x	x	x	x	x	Highest value among the 3-ph
13	An	o	x	x	x	x	x	
14	W L1	x	x	x	x	o	o	◆
15	W L2	o	x	x	x	o	o	◆
16	W L3	o	o	x	x	o	o	◆
17	W sys	o	x	x	x	x	x	Sys = system
18	var L1	x	x	x	x	o	o	
19	var L2	o	x	x	x	o	o	
20	var L3	o	o	x	x	o	o	
21	var sys	o	x	x	x	x	x	Sys = system
22	VA L1	x	x	x	x	o	o	
23	VA L2	o	x	x	x	o	o	
24	VA L3	o	o	x	x	o	o	
25	VA sys	o	x	x	x	x	x	Sys = system
26	PF L1	x	x	x	x	o	o	★
27	PF L2	o	x	x	x	o	o	★
28	PF L3	o	o	x	x	o	o	★
29	PF sys	o	x	x	x	x	x	Sys = system
30	Hz	x	x	x	x	x	x	
31	Phase seq.	o	x	x	x	x	x	
32	ASY L-N	o	x	x	x	x	x	
33	ASY L-L	o	x	x	x	x	x	
34	VA sys dmd	x	x	x	x	x	x	Sys = system ◆
35	W sys dmd	x	x	x	x	x	x	Sys = system ◆
36	A L1 dmd	x	x	x	x	x	x	dmd = (*)
37	A L2 dmd	o	x	x	x	x	x	dmd = (*)
38	A L3 dmd	o	o	x	x	x	x	dmd = (*)
39	VA L1 dmd	x	x	x	x	x	x	dmd = (*)
40	VA L2 dmd	o	x	x	x	x	x	dmd = (*)
41	VA L3 dmd	o	o	x	x	x	x	dmd = (*)
42	W L1 dmd	x	x	x	x	x	x	◆ dmd = (*)
43	W L2 dmd	o	x	x	x	x	x	◆ dmd = (*)
44	W L3 dmd	o	o	x	x	x	x	◆ dmd = (*)
45	kWh	x	x	x	x	x	x	Total and partial
46	kvarh	x	x	x	x	x	x	Total and partial
47	hours	x	x	x	x	x	x	

(x) = available (o) = not available

◆ These variables are available also for the MAX values stored in the EEPROM when the instrument switches off.

★ These variables are available also for the MIN values stored in the EEPROM when the instrument switches off.

(*) dmd value integrated in a programmed time interval.

Alarm parameters and logic



- Block enable.
- Controlled variable (VLN, ...).
- Alarm type (up, down, in windows alarm, out windows alarm).
- Activation function.
- ON set-point.
- OFF set-point.
- ON delay.
- Logical function (AND, OR).
- Digital output (1, 2).

} **A, B, C... up to 16**
parameter control blocks.

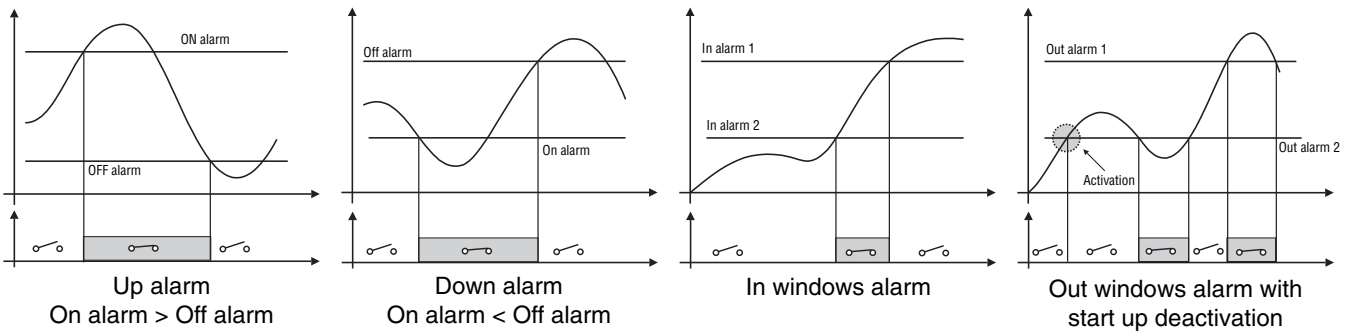

Note: any alarm working mode can be linked to the "start up deactivation" function which disables only the first alarm after power on of the transducer.

AND/OR logical alarm examples:

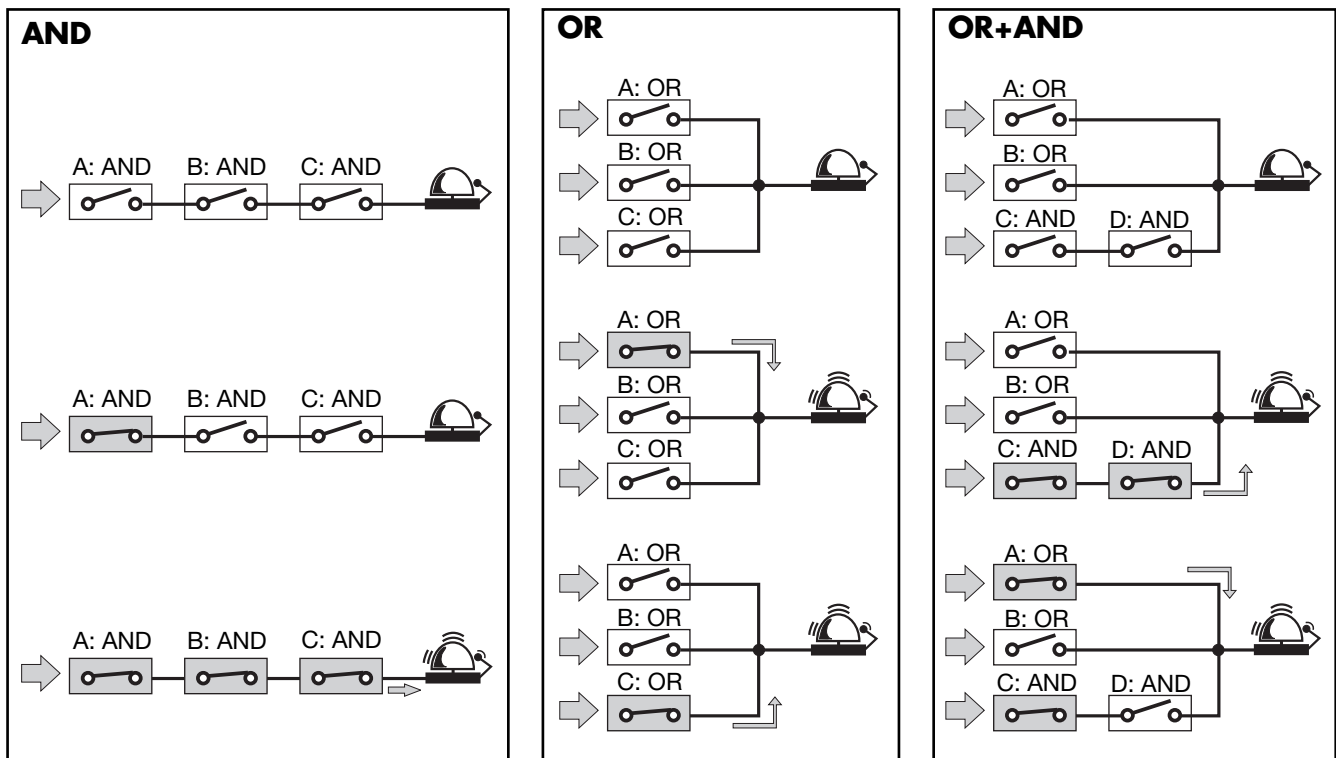

Function Description

Input and output scaling capability. Working of the analogue outputs (y) versus input variables (x)

Figure A

The sign of measured quantity and output quantity remains the same. The output quantity is proportional to the measured quantity.

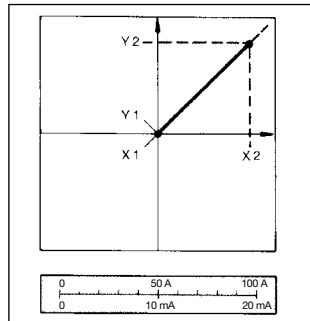

Figure C

The sign of measured quantity and output quantity remains the same. With the measured quantity being zero, the output quantity already has the value $Y_1 = 0,2 Y_2$. Live zero output.

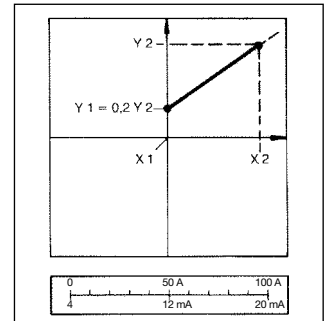

Figure B

The sign of measured quantity and output quantity remains the same. On the range $X_0...X_1$, the output quantity is zero. The range $X_1...X_2$ is delineated on the entire output range $Y_0 = Y_1...Y_2$ and thus presented in strongly expanded form.

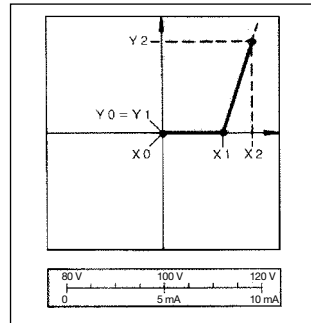
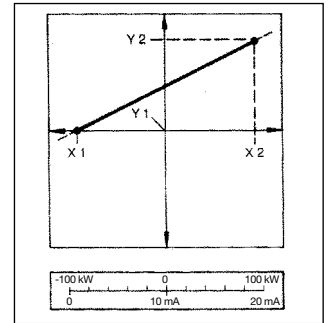

Figure D

The sign of the measured quantity changes but that of the output quantity remains the same. The output quantity steadily increases from value X_1 to value X_2 of the measured quantity.



Insulation between inputs and outputs

	Measuring Input	Relay Output	Open collector output	Dupline output	Analogue Output	RS232/RS485	RS232 (RJ45)	90-260VAC/DC Power supply	18-60VCA/CC Power supply
Measuring input	-	4kV	4kV @ $I \geq 3mA$	2,5kV	4kV @ $I \geq 3mA$	4kV @ $I \geq 3mA$	4kV @ $I \geq 3mA$	4kV	4kV
Relay output	4kV	-	-	-	-	-	4kV	4kV	4kV
Open collector output	4kV @ $I \geq 3mA$	-	-	-	-	-	4kV	4kV	4kV
Dupline output	2,5kV	-	-	-	-	-	2,5kV	2,5kV	2,5kV
Analogue output	4kV @ $I \geq 3mA$	-	-	-	-	-	4kV	4kV	4kV
RS232/RS485	4kV @ $I \geq 3mA$	-	-	-	-	-	4kV	4kV	4kV
RS232 (RJ45)	4kV @ $I \geq 3mA$	4kV	4kV	2,5kV	4kV	4kV	-	4kV	4kV
90-260 VAC/DC	4kV	4kV	4kV	2,5kV	4kV	4kV	4kV	-	-
18-60 VAC/DC	4kV	4kV	4kV	2,5kV	4kV	4kV	4kV	-	-

Waveform of the signals that can be measured

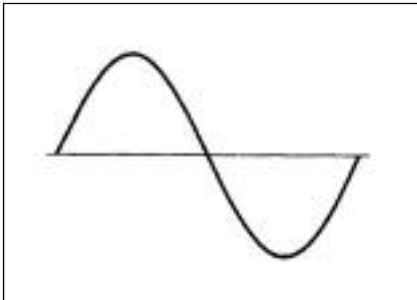

Figure A
Sine wave, undistorted
 Fundamental content 100%
 Harmonic content 0%
 $A_{rms} = 1.1107 |A|$

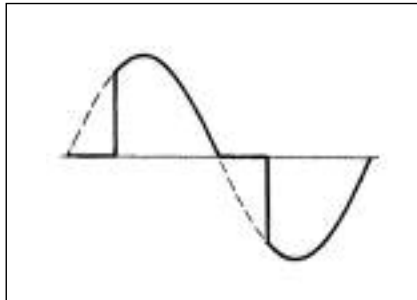

Figure B
Sine wave, indented
 Fundamental content 10...100%
 Harmonic content 0...90%
 Frequency spectrum: 3rd to 16th harmonic
 Additional error: <1% FS

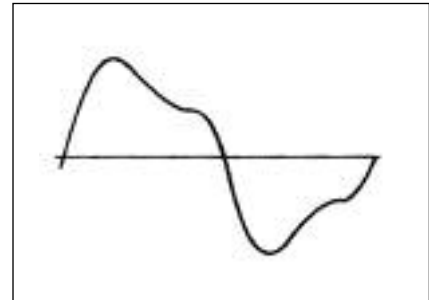
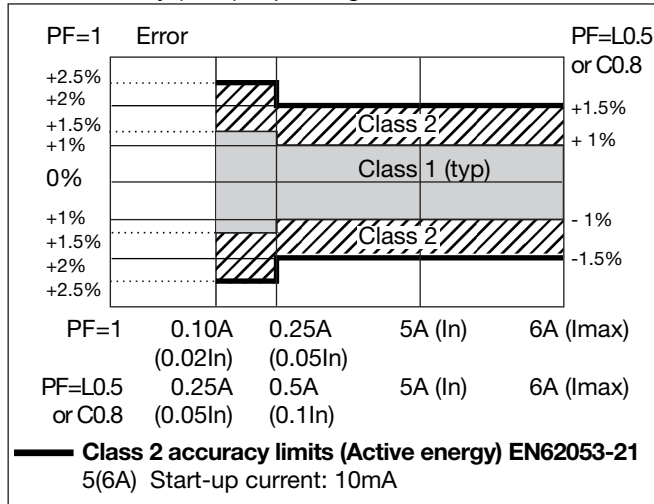

Figure C
Sine wave, distorted
 Fundamental content 70...90%
 Harmonic content 10...30%
 Frequency spectrum: 3rd to 16th harmonic
 Additional error: <0.5% FS

Accuracy

kWh, accuracy (RDG) depending on the current



kvarh, accuracy (RDG) depending on the current

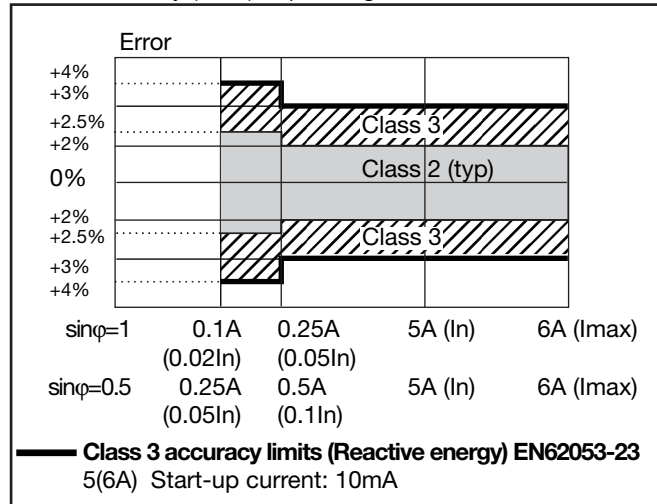

Used calculation formulas

Phase variables

Instantaneous effective voltage

$$V_{IN} = \sqrt{\frac{1}{n} \cdot \sum_1^n (V_{IN})_i^2}$$

Instantaneous active power

$$W_1 = \frac{1}{n} \cdot \sum_1^n (V_{IN})_i \cdot (A_1)_i$$

Instantaneous power factor

$$\cos\phi_1 = \frac{W_1}{VA_1}$$

Instantaneous effective current

$$A_1 = \sqrt{\frac{1}{n} \cdot \sum_1^n (A_1)_i^2}$$

Instantaneous apparent power

$$VA_1 = V_{IN} \cdot A_1$$

Instantaneous reactive power

$$VAR_1 = \sqrt{(VA_1)^2 - (W_1)^2}$$

System variables

Equivalent three-phase voltage

$$V_{\Sigma} = \frac{V_{12} + V_{23} + V_{31}}{3}$$

Voltage asymmetry

$$ASY_{LL} = \frac{(V_{LLmax} - V_{LLmin})}{V_{LL} \Sigma}$$

$$ASY_{LN} = \frac{(V_{LNmax} - V_{LNmin})}{V_{LN} \Sigma}$$

Three-phase reactive power

$$VAR_{\Sigma} = (VAR_1 + VAR_2 + VAR_3)$$

Neutral current

$$An = \overline{A_{L1}} + \overline{A_{L2}} + \overline{A_{L3}}$$

Three-phase active power

$$W_{\Sigma} = W_1 + W_2 + W_3$$

Three-phase apparent power

$$VA_{\Sigma} = \sqrt{W_{\Sigma}^2 + VAR_{\Sigma}^2}$$

Three-phase power factor (TPF)

$$\cos\phi_{\Sigma} = \frac{W_{\Sigma}}{VA_{\Sigma}}$$

Energy metering

$$kWh_i = \int_{t_1}^{t_2} P_i(t) dt \approx \Delta t \sum_{n_1}^{n_2} P_{i,n}$$

$$kVarh_i = \int_{t_1}^{t_2} Q_i(t) dt \approx \Delta t \sum_{n_1}^{n_2} Q_{i,n}$$

Where:

i= considered phase (L1, L2 or L3)
 P= active power; Q= reactive power;
 t_1, t_2 = starting and ending time points of consumption recording; n= time unit; Δt = time interval between two successive power consumptions;
 n_1, n_2 = starting and ending discrete time points of consumption recording

Wiring diagrams "system type selection: 3"

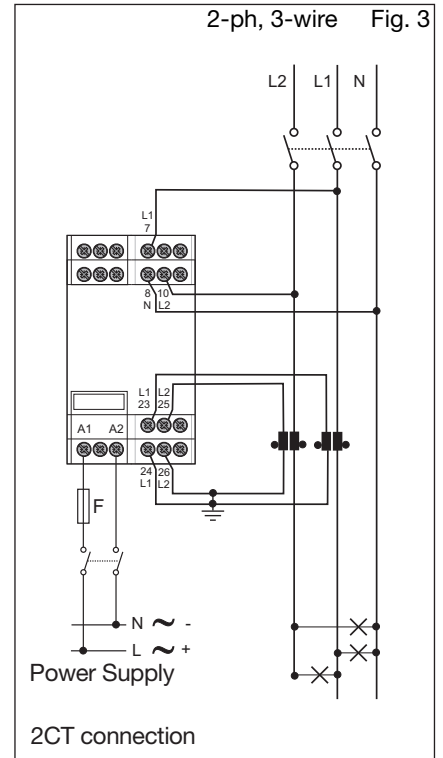
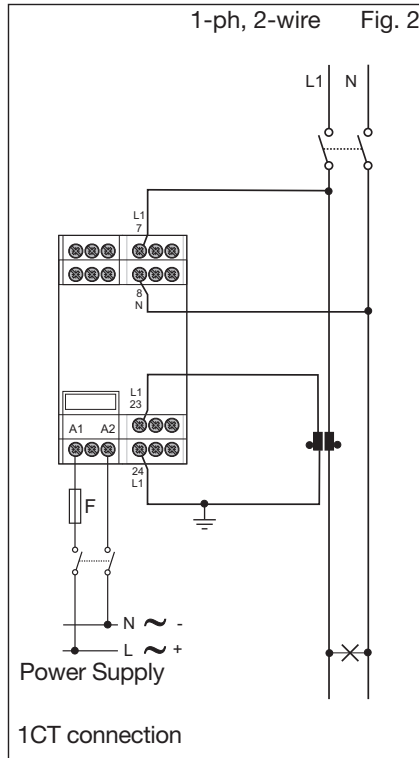
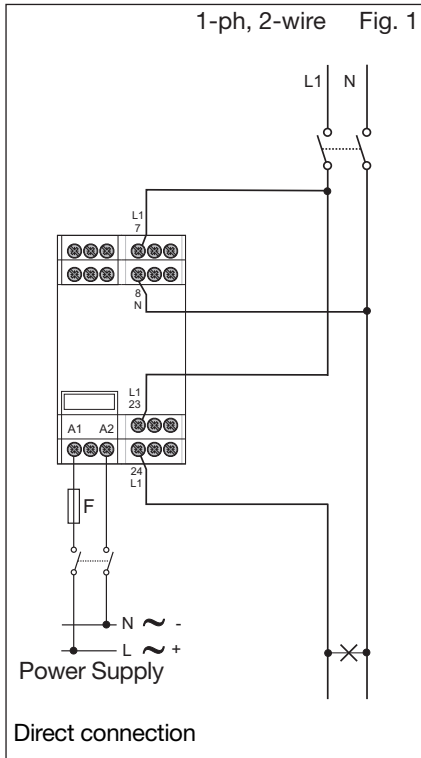

F= 630 mA T (18 to 60VAC/DC)
125 mA T (90 to 260VAC/DC)

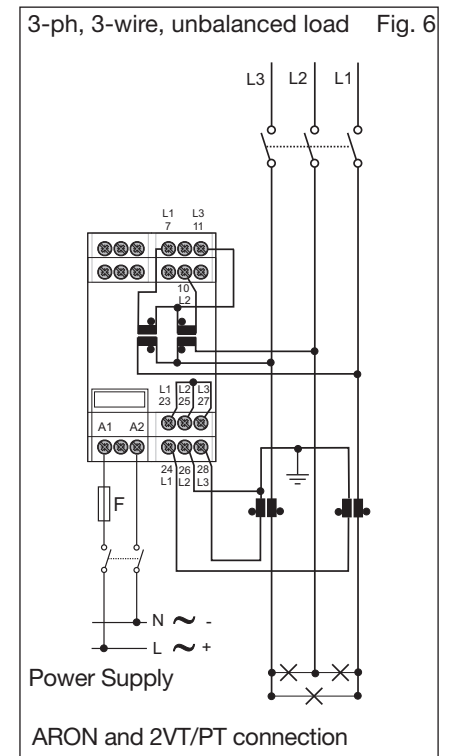
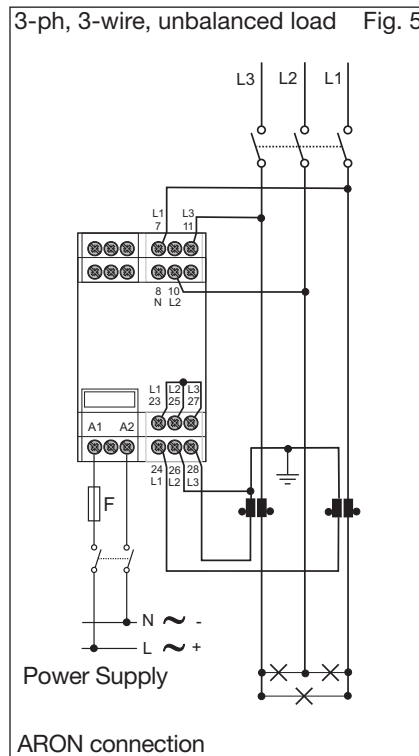
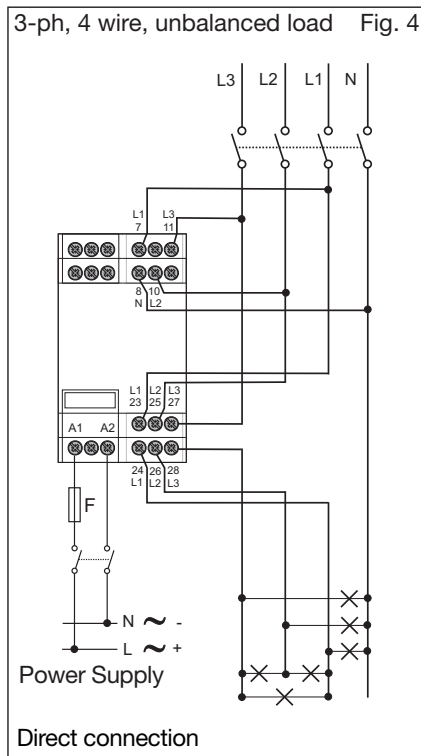

Wiring diagrams "system type selection: 3" (cont.)

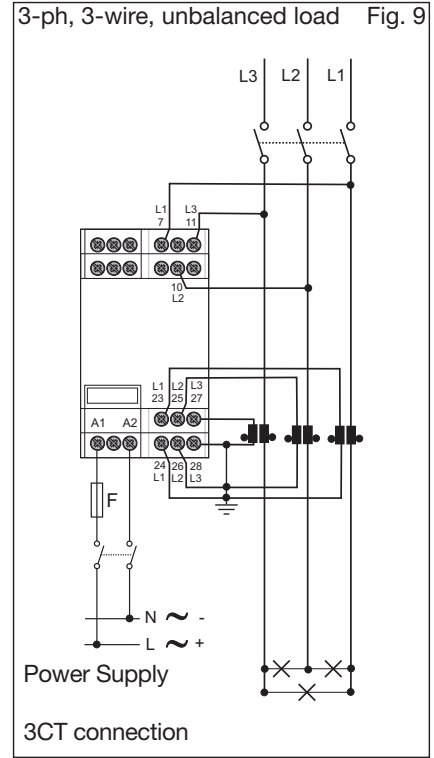
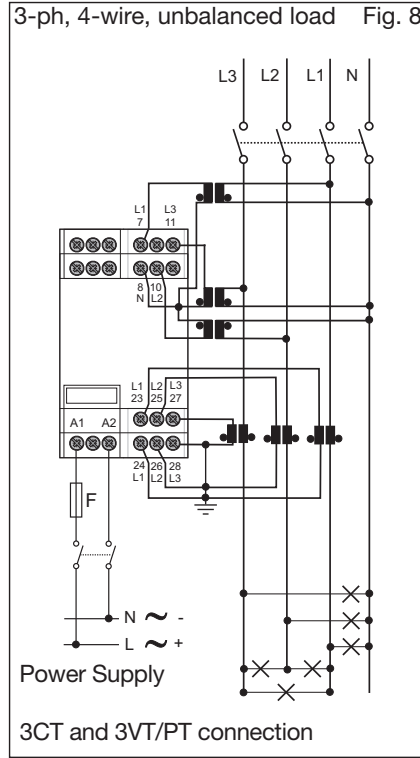
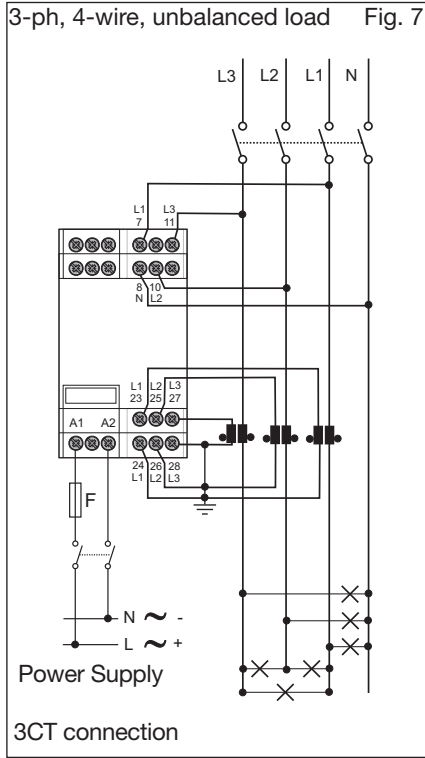

F= 630 mA T (18 to 60VAC/DC)
125 mA T (90 to 260VAC/DC)

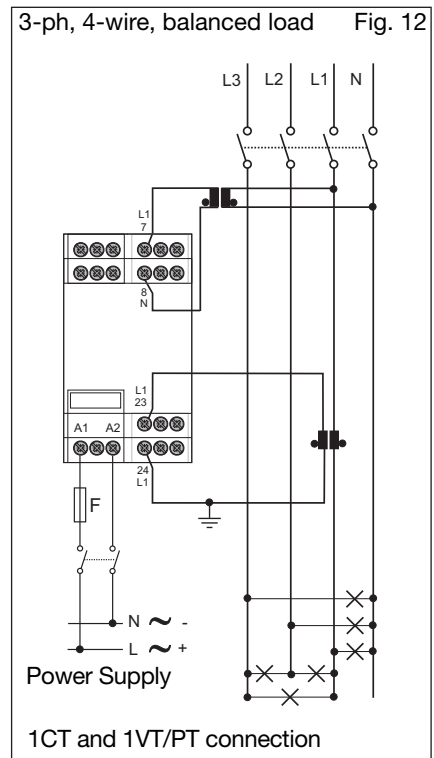
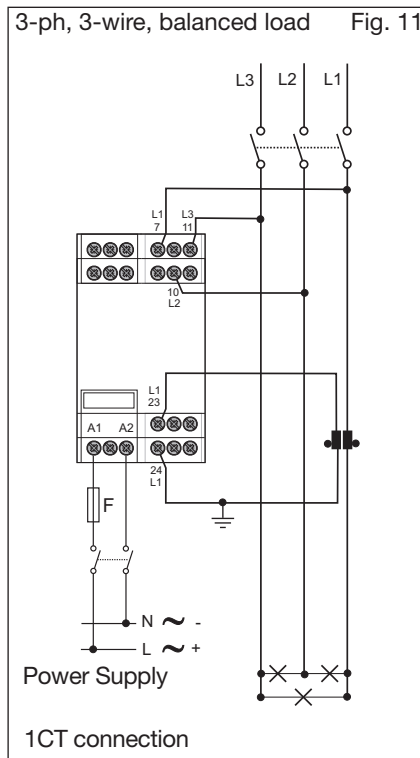
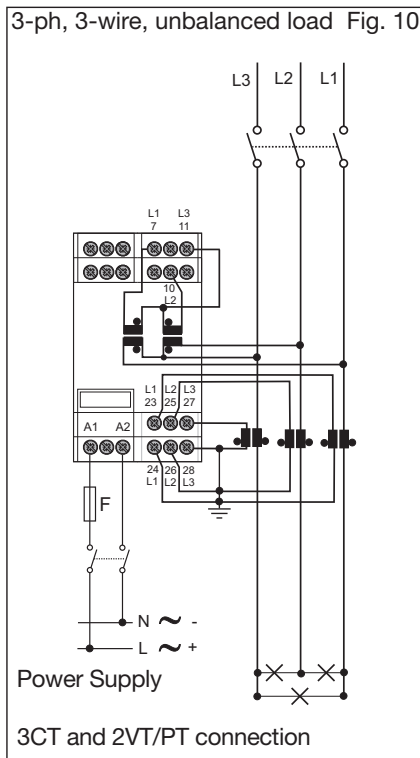

Wiring diagrams "system type selection: 1"

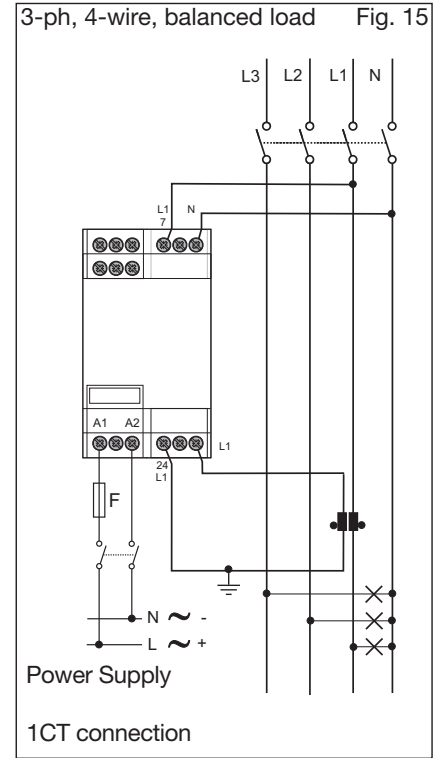
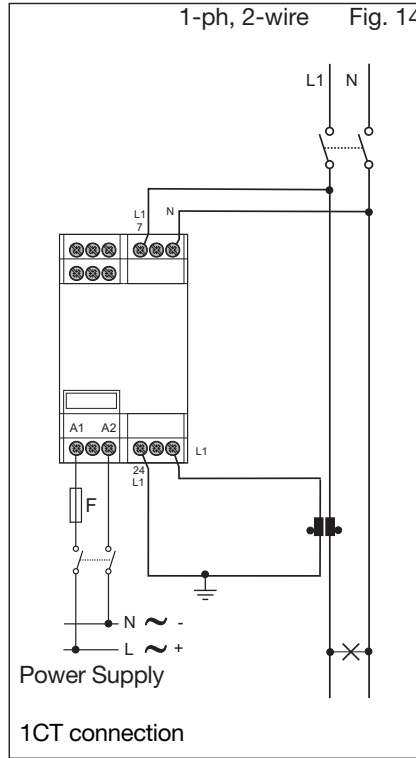
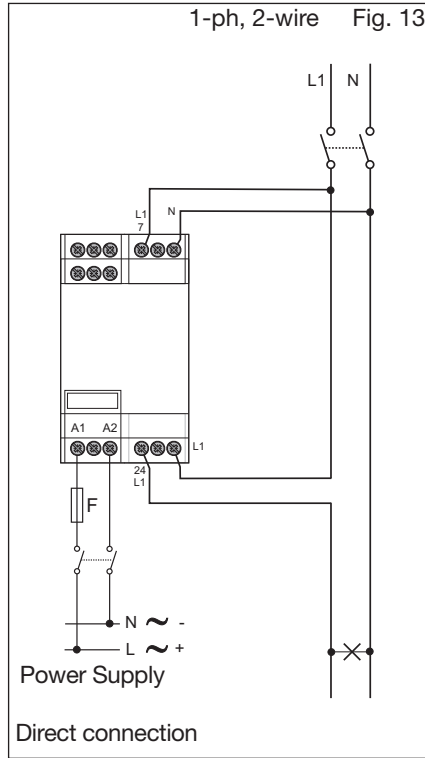

F= 630 mA T (18 to 60VAC/DC)
125 mA T (90 to 260VAC/DC)

Outputs

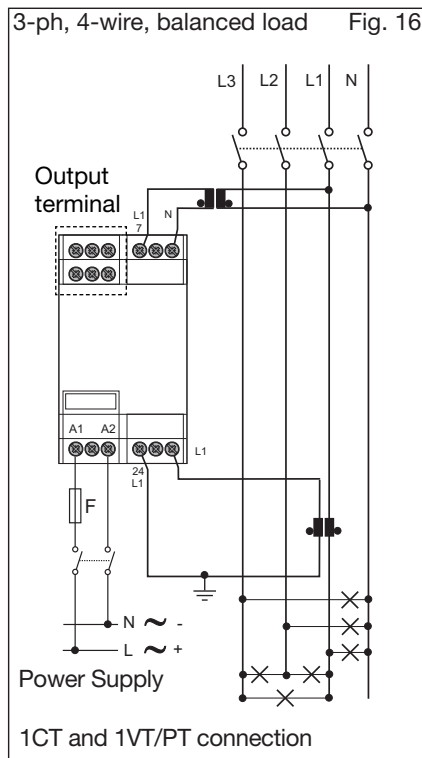

Analogue output 0-20mA

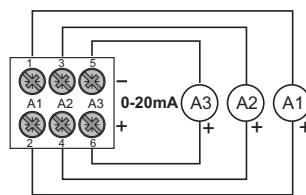

Fig. 17

Analogue output 0-10V

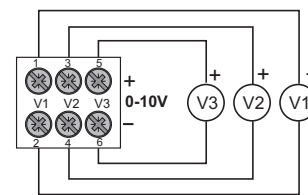

Fig. 18

Relay out.

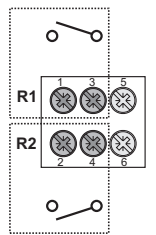

Fig. 19

NOTE: the analogue outputs are not insulated among each other.

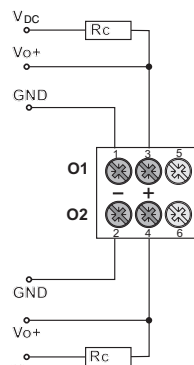

Fig. 20

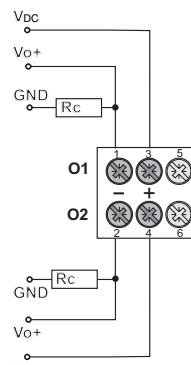
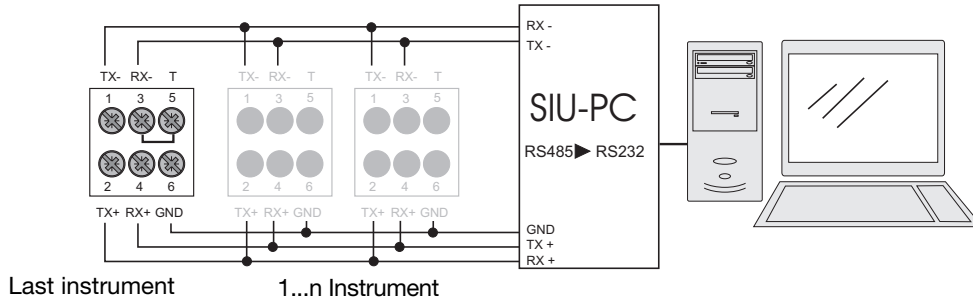

Fig. 21

Open collector outputs: The load resistance (R_c) must be calculated so that the closed contact current is lower than 100mA; the VDC voltage must be lower than or equal to 30V. VDC: power supply voltage (external). Vo+: positive output contact (open collector transistor). GND: ground output contact (open collector transistor).

RS485 serial port connection



4-wire connection of RS485 serial port, the terminalization must be carried out only on the last instrument of the network

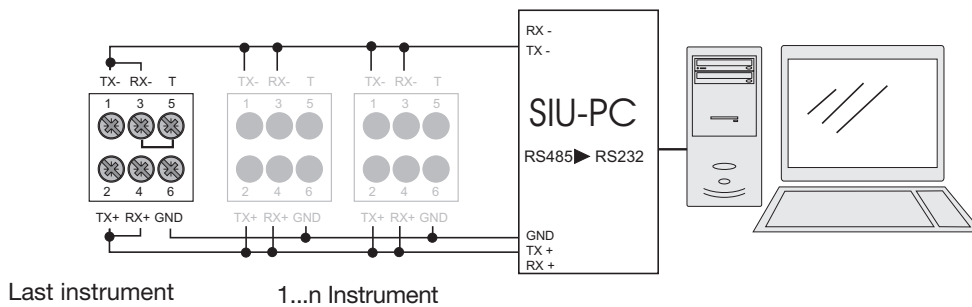

2-wire connection of RS485 serial port, the terminalization must be carried out only on the last instrument of the network

RS232 Serial port connection

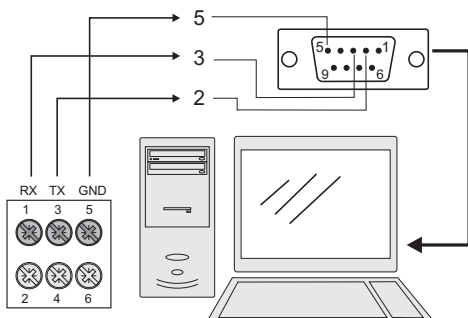

Easy programming



RJ45 communication port for parameters programming. The configuration of the transducer can be easily performed by means of CptASoft. CptASoft-kit includes also 1m long connection cable (RJ45 6-pole / RS232 -pole female).

Outputs connections

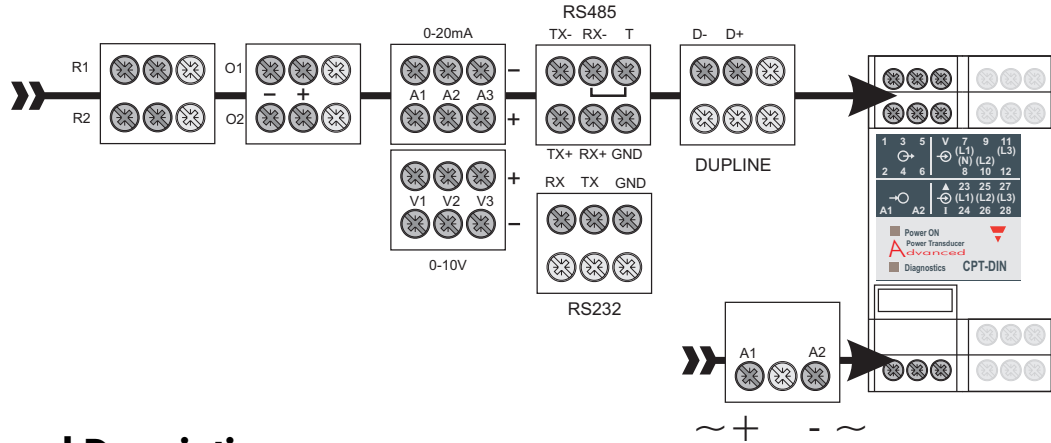

Front Panel Description

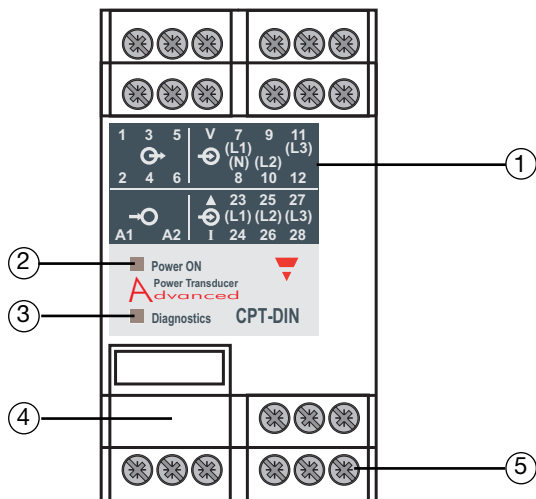

1. Front panel
2. Power ON LED
3. Diagnostics LED
4. Configuration bus (RJ45 connector)
5. Connections screw terminals

Dimensions

