

ENGLISH

MDI40

OPERATING INSTRUCTIONS

• General Features _____	2
• Technical Features _____	3
• Installation _____	9
• Preliminary Operations _____	11
• Front Panel Description _____	12
• Operating mode _____	15

Important:

We suggest you keep the original packing for a further shipping of the instrument.

In order to guarantee a correct use of the instrument, we recommend the user to carefully read the present instruction manual.

CARLO GAVAZZI Instruments

Multi-range μ P-based panel indicators/controllers for voltage, current and temperature measurements

MDI40.V / MDI40.A / MDI40.CF

rev. 1

OPERATING INSTRUCTIONS

Important:

We suggest you keep the original packing for a further shipping of the instrument.

In order to guarantee a correct use of the instrument, we recommend the user to carefully read the present instruction folder.

GENERAL FEATURES

The most important features are:

- measurement of the input value;
- display of the measured value;
- two control points of the measured value;
- display of the minimum / maximum measured value;
- retransmission of the measured value (if available).

The main programming parameters are:

- input selection;

- programming of the scales: electrical scale, displayed scale and decimal point position;
- programming of all the parameters relating to the first set-point;
- programming of all the parameters relating to the second set-point;
- programming of all the parameters relating to the software filter;
- programming of all the parameters relating to the analogue retransmission (when present);
- programming of all the parameters relating to the serial retransmission (when present).

TECHNICAL FEATURES

ACCURACY (VOLTAGE)

± 0.1 % F.S., ± 1 dgt (@ 25°C);

TRMS ± 0.2 % F.S., ± 2 dgt (@ 25°C)

ACCURACY (CURRENT)

± 0.1 % F.S., ± 2 dgt (@ 25°C);

TRMS ± 0.2 % F.S., ± 2 dgt (@ 25°C)

ACCURACY (RTD/ Ω TEMPERATURE)

Pt100/Pt1000: ± 0.15 % F.S., ± 2 dgt (@ 25 °C);

Ni100: ± 0.5 % F.S., ± 1 dgt (@ 25 °C);

Ω : ± 0.1 % F.S., ± 1 dgt (@ 25°C).

ACCURACY (TC TEMPERATURE)

± 0.2 % F.S., ± 2 dgt (@ 25 °C), from -50°C to the higher limit of the input range

TEMPERATURE DRIFT (VOLTAGE)

DC measurement: ± 150 ppm/°C;

AC measurement: ± 200 ppm/°C.

TEMPERATURE DRIFT (CURRENT)

DC / AC measurement: ± 200 ppm/ $^{\circ}$ C

TEMPERATURE DRIFT (RTD / TC / Ω)

± 200 ppm/ $^{\circ}$ C

SAMPLING RATE

V/A measurement: 4 times/sec.; temperature measurement: 2 times/sec.

DISPLAY

7-segment LED, h 14.2 mm

MAXIMUM INDICATIONS

V/A: 3999; temperature: depending on the range and on the type of probe; Ω : 200.0 Ω / 2000 Ω

MINIMUM INDICATIONS

VDC/ADC: -1999; VAC/AAC/ Ω : 0;

temperature: depending on the range and on the type of probe

MEASUREMENT (VOLTAGE / CURRENT)

DC voltage/current and AC voltage/current (measurement of the average value resulting from the sine half-wave rectification of the input voltage/current by RMS calibration)

TRMS MEASUREMENT (VOLTAGE / CURRENT)

AC voltage/current only, TRMS measurement of a distorted wave of voltages/currents. Coupling type: AC, crest factor: ≥ 3 .

INPUTS (VOLTAGE)

200 mV, range: -199.9 mVDC / 0 mVAC to 199.9 mV

2 V, range: -1.999 VDC / 0 VAC to 1.999 V

20 V, range: -19.99 VDC / 0 VAC to 19.99 V

200 V, range: -199.9 VDC / 0 VAC to 199.9 V

500 V, range: -199 VDC / 0 VAC to 500 V

INPUTS (CURRENT)

2 mA, range: -1.999 mADC / 0 mAAC to 1.999 mA

20 mA, range: -19.99 mADC / 0 mAAC to 19.99 mA

200 mA (on request), range: -199.9 mADC / 0 mAAC to 199.9 mA

2 A, range: -1.999 ADC / 0 AAC to 1.999 A

5 A, range: -1.99 ADC / 0 AAC to 5.00 A

FREQUENCY RANGE (VOLTAGE/CURRENT)

From 40 to 400 Hz (accuracy: $\pm 0.5\%$ F.S., ± 2 dgt @ 25 °C, 400 Hz)

FREQUENCY RANGE (TRMS VOLTAGE/CURRENT)

From 40 to 1000 Hz

OVER-RANGE (VOLTAGE / CURRENT)

Continuous: 1.2 Un/In (rated input),

for 1 second: 2 Un/In

INPUTS (RTD TEMPERATURE / Ω)

Pt100, range: -200 °C / 328 °F to +850 °C / 1562 °F

Ni100, range: -60 °C / 76 °F to +180 °C / 356 °F

Ω , range: 0 Ω to 200.0 Ω

Pt1000 (on request), range: -200 °C / 328 °F to +850 °C / 1562 °F

Ω , range: 0 Ω to 2000 Ω (on request)

INPUTS (TC TEMPERATURE)

TC-J, range: -50°C / -58°F to +760°C / +1400°F

TC-L, range: -50°C / -58°F to +760°C / +1400°F

TC-K, range: -200°C / -328°F to +1260°C / +2300°F

TC-T, range: -200°C / -328°F to +400°C / +752°F

TC-E, range: -200°C / -328°F to +1260°C / +2300°F

COMPENSATION (RTD)

For 3-wire connections, line resistance up to 10 Ω

COMPENSATION (TC)

Cold junction, within a temperature range from 0 to 50°C of ambient temperature.

ALARM SET-POINTS

2 independent standard set-points;

Alarm type: the alarm is active only for under/over-range, high alarm, low alarm, low alarm with disabling at power-on, high alarm with latch, low alarm with latch.

Interaction of the two set-points (on request).

Set-point adjustments: programming of minimum and maximum value;

Set-point and hysteresis level: programmable from 0 to 100% of the displayed range;

Activation/deactivation time delay: programmable from 0 to 255 seconds;

Relay status: selectable; normally energized/de-energized;

Output contacts: 2 x SPDT; rating: 5A, 250VAC/VDC, 40W/1200VA, 130.000 cycles;

Min. response time: 400 ms (filter excluded, set-point activation time delay: "0");

Insulation: 2000VRMS between output and measuring input; power-supply for signal output

FILTER

Operating range: from 0 to 3999;

Filtering coefficient: from 1 to 255

DATA HOLD

automatic storage (RAM only) of the minimum and maximum value measured from the previous storage reset onwards.

ANALOGUE RETRANSMISSION (ON REQUEST)

From 0 to 20 mADC / from 0 to 10 VDC, programmable within the whole range of retransmission;

Accuracy and response time: $\pm 0.3\%$ F.S. (@ 25°C) / 500 ms (filter excluded);

Temperature drift: ± 200 ppm/°C

Load: output 0 to 20mA: $\leq 500 \Omega$, output 0 to 10V: $\geq 10 \text{ k}\Omega$

Insulation: by means of optocouplers, 500VRMS between output and measuring inputs, 2000VRMS between output and power-supply input.

SERIAL RETRANSMISSION (ON REQUEST)

RS485; multidrop: one-way (STD); bidirectional (on request); 2 or 4 wires; max. distance 1200m; termination and/or line bias directly on the instrument; 255 programmable addresses; data format: 1 start bit, 8 data bit, no parity, 1 stop bit; baud rate: 1200, 2400, 4800 and 9600 baud selectable by key-pad; protocol according to the standard MODBUS;

One-way communication:

dynamic data (reading only): measurement, valley data, peak data, alarm status;

Static data (reading/writing): all programming data.

Bidirectional communication:

dynamic data (reading only): measurement, valley data, peak data, alarm status;

Static data (reading/writing): all programming data, reset of peak and valley data, reset of alarm set-points with latch.

Insulation: by means of optocouplers, 500VRMS between output and measuring inputs, 2000VRMS between output and power supply inputs

EXCITATION OUTPUT

15 VDC insulated, not stabilized / max. 40 mA;

20 VDC/20mA typical (@ rated value of power supply input).

For MDI40C the power supply output is available only in case of W or Y option.

POWER SUPPLY INPUT

230 VAC -15% +10% 50/60 Hz (standard);

115 VAC -15% +10% 50/60 Hz (on request);

48 VAC -15% +10% 50/60 Hz (on request);

24 VAC -15% +10% 50/60 Hz (on request);

Insulation: 2000 VRMS.

9 to 32 VDC, G.I., max. starting current: 1.2A/200 ms (on request);

40 to 155 VDC, G.I., max. starting current: 0.6A /200 ms (on request);

Insulation: 500 VRMS.

Self-consumption: 5 VA (basic instrument), 7 VA max. with retransmission.

OPERATING TEMPERATURE

From 0 to +50°C (R.H. < 90% non-condensing)

STORAGE TEMPERATURE

From -10 to +60°C (R.H. < 90% non-condensing)

STABILITY OF ACCURACY

6 months

REFERENCE VOLTAGE FOR THE INSULATION

300 VRMS to earth

DIELECTRIC STRENGTH

4000 VRMS for 1 minute

NOISE REJECTION

NMRR: 40 dB, from 40 to 60 Hz

CMRR: 100 dB, from 40 to 60 Hz

EMC: IEC 801-2, IEC 801-3, IEC 801-4 (level 3)

IN ACCORDANCE WITH THE FOLLOWING STANDARDS

EN 61010-1, IEC 1010-1, CEI 66-5, VDE 0411.

CONNECTIONS

Screw-type, detachable

CASING SIZE / DIMENSIONS / MATERIAL

1/8 DIN / 48 x 96 x 124 mm / ABS, self-extinguishing: UL 94 V-0.

PROTECTION DEGREE / WEIGHT

IP 65 (standard) / 470 g. approximately (included retransmission and packing).

ENGLISH

INSTALLATION

Overall dimensions and panel cut-out

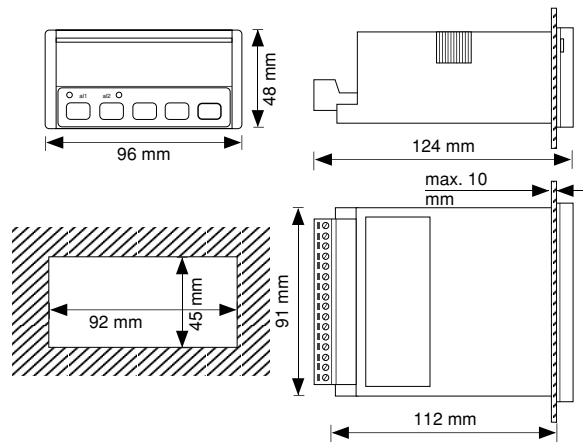

Mounting

Insert the instrument into the panel and fasten it by fixing the two lateral brackets (1) supplied with the instrument to the appropriate location (2), and subsequently locking them by means of the 2 screws (3) supplied with the instrument.

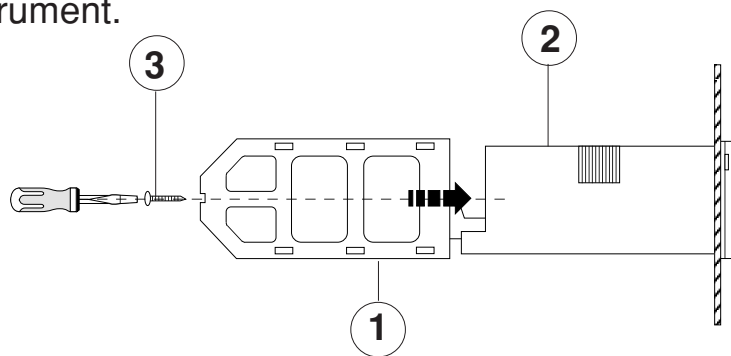

Connections

In order to select the desired range (MDI 40V and MDI40A), jumper, if necessary, between the relevant screw terminals.

Connect MDI 40V (voltmeter) as shown in the figure. Attention: the voltmeter input is to be connected in parallel to the source to be measured.

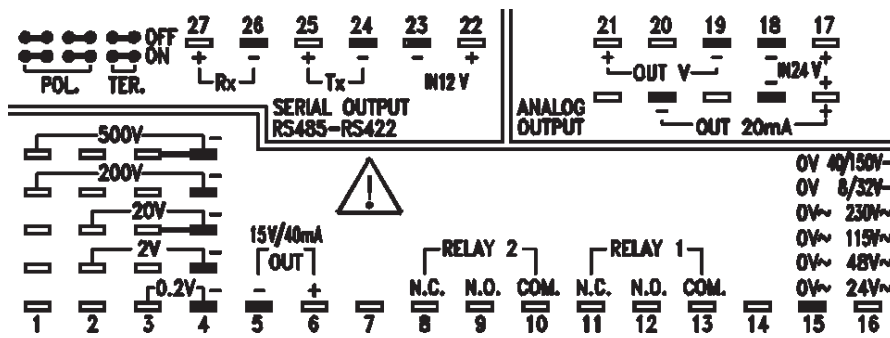

Connect MDI40A (ammeter) as shown in the figure. Attention: the ammeter input is to be connected in series to the source to be measured.

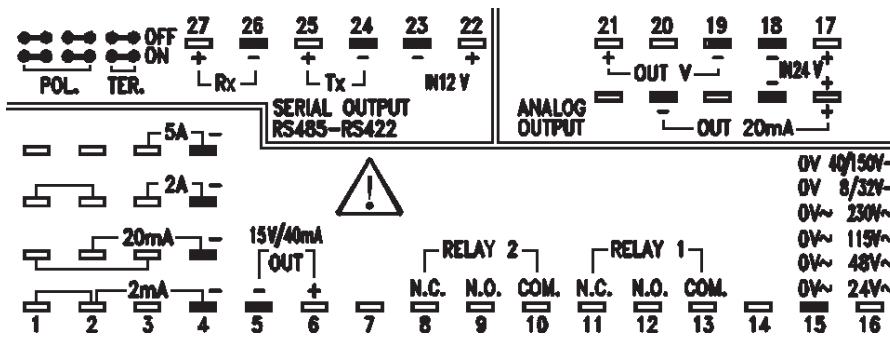

Connection of the signal transmitters (in the models MDI40V and MDI40A):

- 2 wires: signal to the measuring input; power supply to terminal 6; jumper also terminals 4 and 5; loop impedance 60 to 80 Ω (load 20mA).
 - 3 wires: signal to the measuring input; power supply to terminals 5 and 6; jumper also terminals 4 and 5;
 - 4 wires: signal to the measuring inputs; power supply to terminals 5 and 6.
- Connect MDI40CF (thermometer) as shown in the figure. For temperature resistances only: if there are two wires only, jumper terminals 3 and 4.

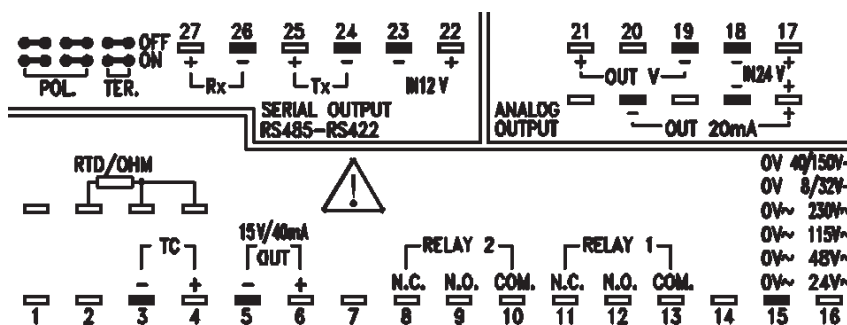

PRELIMINARY OPERATIONS

Before supplying the instrument, make sure that the power supply voltage correspond to what is shown in the label. Example:

MDI40A0BD2AXXIX

SER.N. 960600/20078
POWER 230 VAC 50/60 Hz
INPUT CURRENT
N. 2 set points
OUTPUT 20 mA / 10 VDC

FRONT PANEL DESCRIPTION

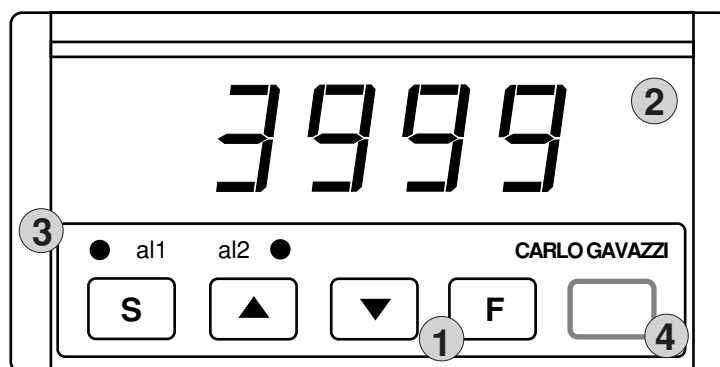

1. Key-pad:

functions available outside the programming phase.

Key to be pressed:

- Displaying of set-point 1 corresponding to a password between 0 and 255;
- Displaying of set-point 2 corresponding to a password between 0 and 255;
- For longer than 2 seconds: modification of set-point 1 (password between 128 and 255 only);
- For longer than 2 seconds: modification of set-point 2 (password between 128 and 255 only);
- + Displaying of maximum measured value (peak feature);
- + Displaying of minimum measured value (valley feature);

F + **▲** For longer than 2 seconds: maximum reset of the measured value (the display will be blinking);

F + **▼** For longer than 2 seconds: minimum reset of measured value (the display blinks);

F For longer than 2 seconds: reset of activated set-points (only for set-points with latch).

1. Key-pad:

functions available in the programming phase.

Key to be pressed:

S For longer than 2 seconds: programming phase entry and password confirmation;

▲ Menu selection (from the first to the last);

▼ Menu selection (from the last to the first);

S Confirmation and entry:

- in the configuration menus;
- in the secondary menus relating to parameters.

▲ In the selected menu / secondary menu:

- increase of displayed value
- modification of parameter selection;

▼ In the selected menu/secondary menu:

- decrease of displayed value
- modification of parameter selection;

F In the menus: exit from the programming phase (message “End“ on the display) and return to the measuring and control function; In the secondary menus: exit and return to the main menu (the modification of the selection or programming will not be saved if the **S** key has not been previously pressed)

2. Display

Alphanumeric indication by means of a 7-segment LED:

- of the measured value;
- of the programming parameters;
- of the measuring abnormal conditions.

3. LED

Indication of the alarm set-point status.

4. Engineering unit window

To insert the interchangeable engineering unit in the special window, proceed as follows: remove the front cover by inserting a suitable screw driver in the special slot on the short sides of the front panel; force gently until the front cover is completely removed. Insert the desired engineering unit by means of a pair of tweezers. Replace the front cover by inserting it first in the lower part and then in the upper part of the locking system.

OPERATING MODE

• Power-on

When you switch the unit on, the instrument shows for approximately 5 seconds the instruments's software revision, for example: **r.1**.

• Displaying, control and diagnostics

The instrument shows continuously the value of the input variable as defined in the programming phase.

The value shown on the display is continuously compared with the value of the two set-points and of the other parameters, thus generating the control function by energizing/de-energizing the output relays.

• Programming

This phase is identified by the blinking of the decimal point on the right side of the display.

To enter the programming phase, press the "**S**" key until "**PAS**" is shown on the display; then "**0**" is displayed: the correct numerical code (password) is to be entered. The following conditions may occur:

- 1) the operator hasn't entered any Password: press the "**S**" key again to enter the configuration menus of the instrument;
- 2) the operator has already entered a Password: select the correct password by means of the "**▲**" key (to increase the value) or "**▼**" key (to decrease it) until the desired value is displayed. Press the "**S**" key to confirm the value: if the password is correct, then the display will show "**PAS**" again followed by the relating numerical code; press the "**S**" key once more in order to display the first configuration menu; if the

password is not correct, the display shows “**End**” and the instrument goes back to the measuring and control phase.

PROGRAMMING OF A NEW PASSWORD AND AUTOMATIC SELECTION OF THE PROTECTION LEVEL OF THE CONFIGURATION DATA.

To enter the new Password:

- if the Password is “0”, press the “**S**” key when the display shows the “**PAS**” message for the second time; enter the desired numerical code using the “**▲**” or “**▼**” keys, then confirm it by pressing the “**S**” key: the display will show the first configuration menu (“inP”);
- if the Password has already been entered, you can modify it following the procedure described at No. 2); after the “**PAS**” message has been shown a second time, enter the new numerical code using the “**▲**” or “**▼**” keys and confirm it by pressing the “**S**” key: the display will show the first configuration menu (“inP”).

Data protection levels:

- if the password is “0”, the configuration data are not protected by undesired accesses;
- if the Password is a number between “1 and 127”, the configuration data are almost entirely protected against undesired accesses;
- if the Password is a number between “128 and 255”, the configuration data are protected against undesired accesses except for the programming of the values (“SEt”) of set-point 1 and/or 2.

It is possible to reset the Password by entering the number 3584.

- All programming/configuration steps of MDI40 are shown in the flow chart on the top right of this page. The flow chart has been conceived to make the operator better understand the programming structure**

of MDI40 indicating the position of the current function with regards to the others. The flow chart also makes more easily understandable the commands to be used in the configuration phase.

- See the chapter “Front panel description” for information regarding the use of the key-pad and the relevant main functions.

- **Glossary of displayed symbol:**

(the symbols like **PAS** in a black background belong to the main menu; the symbols like **AC** in a white background belong to the secondary menu).

- **PAS** : access key to programming
- **inP** : menu to select measuring inputs

For MDI40V and MDI40A only:

- **AC** : selection of AC voltage/current measurements;
- **dC** : selection of DC voltage/current measurements.

For MDI40CF only:

- **rtd** : selection of thermoresistance/Ohm measurements;
- **tC** : selection of thermocouple measurements
- **r1**, **r2**, **r3**, **r4**, **r5** : range selection (see table “inP” in the flow chart).
- **SCA** : menu to program the scaling parameters
- **Lo.E** : min. value of electrical scale (see table “inP” in the flow chart).

Enter the minimum value that is to be measured (zero scale).

- **Hi.E** : max. value of electrical scale (see table “inP” in the flow chart).
- Enter the maximum value to be measured (full scale).

Note: in the resistance measurements (“inP” ⇒ “rtd” ⇒ “r5”) the maximum electrical full scale to be entered is: “2000” and the corresponding value of “Hi” must be “200.0” in order to take true resistance measurements with a 0.1Ω resolution.

NOTE: if the measured variable goes beyond the scale limits "Lo.E"/"Hi.E", the value displayed during the measuring phase will be blinking and updated with reference to the measured value up to the maximum displaying range ("dC" and temperature measurements: -1999/3999; "AC" and resistance measurements: 0/3999).

d.P : decimal point position in the Hi-Lo scale.

Lo : min. value of the displayed scale. Enter the value to be displayed in correspondence with the minimum value of the electrical scale "Lo.E". Example: "Lo.E"=4.00mA \Rightarrow "Lo"=1000mbar, means that when the value measured by MDI40 is 4mA, the displayed value will be 1000mbar.

Hi : max. value of the displayed scale. Enter the value to be measured in correspondence with the maximum value of the electrical scale "Hi.E". Example: "Hi.E"=19.99mA \Rightarrow "Hi"=3000mbar, means that when the value measured by MDI40 is 20mA, the displayed value will be 3000mbar.

NOTE: electrical scale and displayed scale must have:

- corresponding values (Lo.E=Lo, Hi.E=Hi), if the same value is to be both measured and displayed.
- different values, if the signal to be measured is different from the one to be displayed (see examples of "Lo" and "Hi").
- inverted values, if an increasing signal to be measured must correspond to a decreasing value to be displayed (scale inversion).

Example: "Lo.E"=4.00mA \Rightarrow "Lo"=3000mbar; "Hi.E"=19.99mA \Rightarrow "Hi"=0mbar, means that when the measured value increases from 4 to 20mA, the displayed value decreases from 3000mbar to 0.

As you can see, the scales can be programmed with absolute freedom.

NOTE: to display temperature values as "°F", it is necessary to program the electrical scale as "°C" and enter the values for the displayed scale

according to the following relationship: $^{\circ}\text{F} = (1.8 \times ^{\circ}\text{C}) + 32$.

Example: “Lo.E” = $-50^{\circ}\text{C} \Rightarrow$ “Lo” = -58°F ; “Hi.E” = $+760^{\circ}\text{C} \Rightarrow$ “Hi” = $+1400^{\circ}\text{F}$, means that the new measuring range becomes -58° to $+1400^{\circ}\text{F}$. The data to be entered in the displayed scale can be calculated either by means of the above mentioned “ $^{\circ}\text{F}$ ” relationship, or using the data of the relevant measuring range (see chapter “Technical Features”, paragraph “Inputs temperature” on the previous page).

SP.1/SP.2 : menu to select the programming of the set-point parameters.

tYP : selection of the type of control.

oFF : signalling of the abnormal condition. The relay is activated when a burn-out condition occurs or the measurement is outside the electrical range (displaying and blinking of the measured value or displaying of the “EEE”/ “-EE” message).

Note: by selecting this function the “Lo.S”, “Hi.S”, “SP.1”, “HYS” parameters are not active.

do : down/low alarm set-point. The relay will be activated when the measured value goes below the set-point value.

uP : up/high alarm set-point. The relay will be activated when the measured value goes over the set-point value.

d.do : alarm set-point similar to “do”, but with alarm inhibition eventually present when MDI40 is turned on. The control starts only after the first condition of non-alarm has been signalled.

uP.L : up/high alarm set-point with latch function.

The alarm functions as per “uP”, but the alarm can be reset only manually when the **F** key is pressed for at least 2 seconds during the measuring phase.

do.L : down/low alarm set-point with latch function. The alarm functions as per “do” and can be reset only manually when the **F** key is pressed for at least 2 seconds during the measuring phase.

Lo.S : minimum set-point value, which is programmable within the range: $Lo (Hi) < Lo.S < Hi (Lo)$. This limit to the set-point’s amplitude is very useful when the set-points are managed outside the programming phase.

Hi.S : maximum set-point value, which is programmable within the range: $Lo.S < Hi.S < Hi (Lo)$. This limit to the set-point’s amplitude is very useful when the set-points are managed outside the programming phase.

SEt : value of the alarm set-point to be programmed within the following range: $Lo.S < SEt < Hi.S$.

HYS : hysteresis value of the set-point. The hysteresis is a numerical value included within the range: $0 < HYS < 3999$ and represents the difference between the value of the ON alarm status and the value of the OFF alarm status. The hysteresis modifies the value of the OFF alarm status not only with regards to the set alarm value, but also with regards to the alarm type: the hysteresis value is summed to the set value if the alarm type is “do” and subtracted from the set value if the alarm type is “uP”.

Example:

“do” alarm, “SEt”=2200 (value of the ON alarm status), hysteresis “HYS”=12 \Rightarrow resulting OFF value (end of alarm status): 2212 (resulting from $2200 + 12$).

“uP” alarm, “SEt”=2200 (value of the ON alarm status), hysteresis “HYS”=12 \Rightarrow resulting OFF value (end of alarm status): 2188 (resulting from $2200 - 12$).

NOTE: the hysteresis is to be programmed according to the displayed range.

oF.d : value expressed in seconds of the time delay at the alarm set-point's deactivation (OFF).

Value to be programmed within the range: $0 < \text{oF.d} < 255$.

This delay can be useful when it is necessary to guarantee the alarm output activation for a sufficiently long time which is to be acquired by the processing system connected downstream MDI40.

on.d : value expressed in seconds of the time delay at the alarm set-point's activation (ON). This value is to be programmed within the range: $0 < \text{on.d} < 255$.

This value can be useful when it is necessary to avoid the alarm set-point's activation if the alarm duration is not long enough. Example: when the pressure to be measured decreases very quickly because of air bubbles, but this is not a danger for the monitored plant.

RLY : normal status of the relay coil.

nd : normally de-energized coil.

nE : normally energized coil.

FIL : menu to program the digital filter's parameters.

This function allows you to solve two different kinds of problems:

- stabilize the value of the instantaneous measurement displayed by MDI40 when the value is not enough stable from the beginning and will not therefore allow either a clear reading on the display or a good control by the alarm set-points;
- allow an amplitude of the displayed scale as regards to the electrical one >2 .

An example of how the electrical scale is to be used can be the

measurement of a process signal from a transmitter: 0 to 20mA, 4 to 20mA, 0 to 10V, 0 to 5V, 1 to 5V and so on which can correspond to a pressure, humidity, temperature, etc. In this case the measured signal managed by the electrical scale (see “Lo.E”, “Hi.E”) has a numerical value which is completely different from the one of the displayed scale (see “Lo”, “Hi”).

Fi.S: activation range of the digital filter. This value is programmable within the range: $0 < \text{Fi.S} < 3999$.

The programmable numerical value represents the fluctuation range of the value which has been measured and displayed by MDI40. In the first configuration phase this value must be 0 and the right value is to be entered only after the verification of the possible fluctuation.

Example: the measured instantaneous value varies from 1204 to 1210, and the value to be entered as “Fi.S” is 6 (1210 - 1204).

Fi.C: value of the filtering coefficient. Value to be programmed within the range: $1 < \text{Fi.C} < 255$.

The higher “Fi.C”, the higher the filtering of the measured value and the longer the updating time of the displayed value, the alarm set-points and the analogue retransmission.

NOTE: for a correct working of the filter, the relative coefficient must satisfy the following relationship: $1 < \text{Fi.C} < (\text{Fi.S} \times 8) < 255$.

Example: in order to display a temperature with a resolution of 0.1°C , set “Lo.E”= -20°C \Rightarrow “Lo”= -20.0°C , “Hi.E”= 200°C \Rightarrow “Hi”= 200.0°C . In this case the scaling amplitude will be 10 times wider with an clear fluctuation of the value displayed in the measuring phase. In order to stabilize the value it is necessary the parameters “Fi.S” and “Fi.C”. The value fluctuates of 0.5°C max., therefore “Fi.S”= 0.5 and the filtering coefficient

is to be entered making various attempts starting from a minimum value, for example “Fi.C”=3. The datum will not remain stable, therefore “Fi.C” is to be increased; in our case the optimum value is “Fi.C”=15.

A.ou menu to program the parameters relating to the analogue output.

Lo.A: value to be expressed as % of the output range (0/20mA-0/10V) to be generated in correspondence with the minimum measured value (Lo.E/Lo parameters). Value programmable within the range: 0.00 < Lo.A < 99.99. Example: “Lo.E”=“Lo”=-100°C that must correspond to a retransmitted signal of 4mA.

“**Lo.A**” (%) = $\frac{100 \times ?mA}{20}$ that in our example corresponds to:

$100 \times 4mA / 20 = 20\%$, therefore enter 20.00.

Example: “Lo.E”=“Lo”=-100°C that must correspond to a retransmitted signal of 1V.

“**Lo.A**” (%) = $\frac{100 \times ?V}{10}$ that in our example corresponds to:

$100 \times 1V / 10 = 10\%$, therefore enter 10.00.

Hi.A : value expressed as % of the output range (0/20mA-0/10V) to be generated in correspondence with the maximum measured value (Hi.E/Hi parameters). Value to be programmed within the range: 0.00 < Hi.A < 99.99. Example: “Hi.E”=“Hi”=+200°C that must correspond to a retransmitted signal of 18mA.

“**Hi.A**” (%) = $\frac{100 \times ?mA}{20}$ that in our example corresponds to:

$100 \times 18mA / 20 = 90\%$, therefore enter 90.00.

Example: “Hi.E”=“Hi”=+200°C that must correspond to a retransmitted signal of 5V.

“Hi.A” (%) = $\frac{100 \times ?V}{10}$ that in our example corresponds to:

$100 \times 5V/10 = 50\%$, therefore enter 50.00.

Also in this case, as per the electrical and displayed scale, it is possible to invert the scale, that is, a decreasing value of the retransmitted signal may correspond to an increasing value of the input variable

S.ou : menu to program the serial output's parameters

MDI40 is provided (on request) with an RS485 serial interface that allows the communication with a PC or PLC. It is possible to retransmit both the static and the dynamic variables and make connections with more than one MDI40 (multidrop).

Add : address value programmable within the range: $1 < \text{Add} < 255$.

b.dr : baud rate programming of the data, see table “S.ou” in the flow-chart.

For further information on the serial interfacing, see the special literature.

Diagnostic messages

“**EEE**” blinking indication: burn-out or overcoming of the displaying range (value to be displayed > 3999).

“**-EE**” blinking indication: burn-out or overcoming of the displaying range (value to be displayed > -1999).

Alarm status following sensor's breakage.

TC

Status	oFF	do	uP	d.do	uP.L	do.L
Opening	on	oFF	on	oFF**	on*	oFF*
Short-circuit	/	/	/	/	/	/

* Depending on the "latch" status.

** Depending on the first activation.

RTD

Status	oFF	do	uP	d.do	uP.L	do.L
Opening (1 of the 3 wires)	on	oFF	on	oFF**	on	oFF
Short-circuit	on	on	oFF	oFF**	oFF*	on*

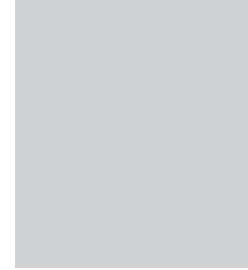

ENGLISH

