

Panel Meters and Controllers

Controller for AC/DC Voltage Measurements

Type MDI 40 V



- 3 3/4-dgt multi-range μ P-based controller
- For AC/DC voltage measurements
- Ranges from 200 mV to 500 V
- All software functions selectable by key-pad
- Peak/valley function
- Password protection of programming parameters
- 2 independent alarm setpoints
- Alarm for over-range, up-alarm, down-alarm, down alarm with disabling at power-on, up/down-alarm with latch
- Degree of protection: IP 65
- Optional analogue output (20 mA/10 VDC)
- Optional serial RS 485 output
- MODBUS, JBUS protocol.

Product Description

3 3/4-dgt multi-range μ P-based controller for AC/DC voltage measurements. Scaling and setpoints are fully programmable by user-friendly key-pad. The MDI 40 V includes

peak/valley function and password protection. The housing is easy to mount and ensures a degree of protection of IP 65.

Ordering Key **MDI40V0BD2A XX IX**

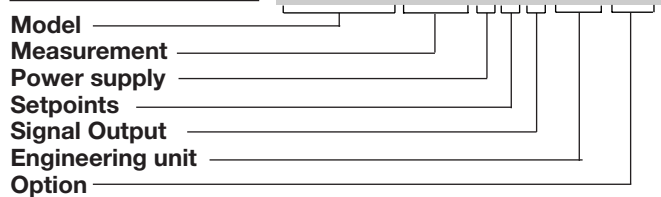

Type Selection

| Measurements | Power supply | Signal output | Options |
|--|---|--|--|
| V0B: Standard (40-400 Hz) 200 mV 2 V 20 V 200 V 500 V | A: 24 VAC, -15% +10%, 50/60 Hz ¹⁾ B: 48 VAC, -15% +10%, 50/60 Hz ¹⁾ C: 115 VAC, -15% +10%, 50/60 Hz ¹⁾ | X: None A: Analogue: from 0 to 20 mA /from 0 to 10 V R: Serial: RS 485 unidirectional S: Serial: RS 485 bidirectional | IX: Degree of protection IP 65 (standard) 01: Interactive setpoints + IP 65 ¹⁾ XT: Tropicalization + IP 65 ¹⁾ |
| V0T: True RMS (40-1000 Hz) 200 mV 2 V 20 V 200 V 500 V | D: 230 VAC, -15% +10%, 50/60 Hz (standard) E: 120 VAC, -15% +10%, 50/60 Hz ¹⁾ F: 240 VAC, -15% +10%, 50/60 Hz ¹⁾ 3: 9 to 32 VDC with galvanic insulation ¹⁾ 6: 40 to 150 VDC with galvanic insulation ¹⁾ | W: Analogue (A) + serial (R) Y: Analogue (A) + serial (S) | |

¹⁾ On request

Input Specifications

| | | | |
|---|--|---------------------------------|---|
| Rated input | 200 mV, 2 V, 20 V, 200 V, 500 V AC/DC, 40-400 Hz | Temperature drift | DC ± 150 ppm/ $^{\circ}$ C AC ± 200 ppm/ $^{\circ}$ C AC TRMS ± 200 ppm/ $^{\circ}$ C |
| Accuracy | | Sampling rate | 4 times/s, dual slope 16 bits A/D converter. |
| DC DC voltage measurements, (@ 25 $^{\circ}$ C) | $\pm 0.1\%$ f.s., ± 1 dgt | Display | 7-segment LED, h 14.2 mm |
| AC standard AC voltage measurements (@25 $^{\circ}$ C, 50/60 Hz, 5 to 100% f.s.) | $\pm 0.1\%$ f.s., ± 2 dgt | Max. and min. indication | DC Max. 3999 min. -1999 AC Max. 3999 min. 0 |
| AC TRMS AC TRMS (@ 25 $^{\circ}$ C) | $\pm 0.2\%$ f.s., ± 2 dgt | | |

Input Specifications (cont.)

| | | | |
|-----------------------|--|-----------------------------|---|
| AC Measurement | | Input ranges (cont.) | |
| Standard | Measurement of the average value resulting from the sine half-wave rectification of the input voltage by rms calibration | 200 V | -199.9 to 199.9 VDC 0 to 199.9 VAC |
| TRMS | True rms Coupling type : AC Crest factor: ≥ 3 | 500 V | Input impedance: 1 M Ω -199 to 199 VDC 0 to 500 VAC Input impedance: 1 M Ω |
| Input ranges | | Overload protection | |
| 200 mV | -199.9 to 199.9 mVDC 0 to 199.9 mVAC Input impedance: 10 k Ω | Continuous | 1.2 x rated input |
| 2 V | -1.999 to 1.999 VDC 0 to 1.999 VAC Input impedance: 100 k Ω | For 1s | 2 x rated input |
| 20 V | -19.99 to 19.99 VDC 0 to 19.99 VAC Input impedance: 100 k Ω | Key-pad | 4 keys: "S" for menu selection; "UP" and "DOWN" for value programming/function selection; "F" for special functions. |

Output Specifications

| | | | |
|-------------------------------|---|------------------------|--|
| Alarms | | Analogue output | |
| Number of setpoints | 2 independent (standard) | Range | 0 to 20 mA DC, 0 to 10 VDC |
| Alarm types | Over-range, up alarm, down alarm, down alarm with disabling at power-on, up alarm with latch, down alarm with latch | Scaling factor | Programmable within the whole range of the signal output; it allows the management of all values from 0 to 20 mA/ from 0 to 10 V |
| Special function | Interaction of the two setpoints (on request) | Accuracy | ≤ 500 ms |
| Setpoint adjustment | 0 to 100% of the displayed range | Response time (@ 25°C) | $\pm 0.3\%$ f.s. |
| Limits of setpoint adjustment | Programmable minimum and maximum values | Temperature drift | ± 200 ppm/°C |
| Hysteresis | 0 to 100% of the displayed range | Load: 20 mA output | $\leq 500 \Omega$ |
| On-time delay | 0 to 255 s | 10 V output | $\geq 10 \text{ k}\Omega$ |
| Off-time delay | 0 to 255 s | Insulation | By means of optocouplers, 500 V _{rms} outputs to measuring inputs |
| Relay status | Normally energized/de-energized | | 4000 V _{rms} output to supply input |
| Output type | | Serial output | |
| Contact | 2 x SPDT | Type | RS 485 |
| Rating | 5 A, 250 VAC/VDC, 40 W / 1200 VA, 130.000 cycles | Multidrop | Unidirectional (std), bidirectional (on request) |
| Min. response time | ≤ 400 ms, filter excluded, setpoint on-time delay: "0" | Connections | 2 or 4 wires, max. distance 1200 m, termination and/or line biasing directly on the instrument |
| Insulation | 2000 V _{rms} between output and measuring inputs, excitation output | Addresses/protocol | 255, selectable by key-pad/ MODBUS, JBUS |
| Excitation output | | Data (unidirectional) | |
| Voltage | 15 VDC non-stabilized/40 mA max. (only in case of W or Y option) | Dynamic (reading only) | Measurement, data hold of minimum value, data hold of maximum value, alarm status |
| Insulation | 100 V _{rms} output to measuring input 4000 V _{rms} output to AC supply input 500 V _{rms} output to DC supply input | Static (reading only) | All programming data |

Output Specifications (cont.)

| | | | |
|--|--|------------------------------|---|
| Serial output (cont.) | Measurement, data hold of minimum value, data hold of maximum value, alarm status All programming data, min./max. data hold reset, reset of alarm set-points with latch 1-start bit, 8-data bit, no parity, 1 stop bit | Serial output (cont.) | 1200, 2400, 4800 and 9600 bauds selectable By means of optocouplers, 500 V _{rms} output to measuring inputs 4000 V _{rms} output to supply input |
| Data (bidirectional, on request) Dynamic (reading only) | | Baud-rate | |
| Static (reading/writing) | | Insulation | |
| Data format | | | |

Software Functions

| | | | |
|-------------------------------|--|---|--|
| Peak and valley values | Automatic storage (RAM only) of the min. and max. value measured from the last reset | Scaling factor (cont.) | Programmable within the whole measuring range Programmable within the displaying range Programmable within the whole displaying range |
| Password | Numeric code of max. 3 digits; 3 protection levels of the programming data Password "0", no protection. Password from 1 to 127, all data are protected Password for 128 to 255, all data protected except for the setpoints | Electrical scale | |
| 1st level | | Decimal point position | |
| 2nd level | | Displayed scale | |
| 3rd level | | Diagnostics | The display flashes when the limits of the displayed range are exceeded, the data are updated up to the maximum read-out EEE (AD/DC) - EE (DC) |
| Measurement selection | AC/DC voltage | Over range Under range | |
| Scaling factor | Electrical scale compression, compression/expansion of the displayed scale (max. 2 without filter, > 2 with filter) | Filter | From 0 to 3999 From 1 to 255 |
| Operating mode | | Filter operating range Filtering coefficient | |

Supply Specifications

| | |
|--------------------------|--|
| AC supply | 230 VAC, -15%+10%, 50/60 Hz (standard) 24 VAC, 48 VAC, 115 VAC, 120 VAC, 240 VAC, -15%+10%, 50/60 Hz (on request) |
| Insulation | 4000 V _{rms} supply input to all the other inputs/outputs |
| DC supply | 9 to 32 VDC, galvanic insulation, max. inrush current: ≤ 1.2 A/200 ms (on request) 40 to 150 VDC, galvanic insulation, max. inrush current: ≤ 0.6 A/200 ms (on request) |
| Insulation | 500 V _{rms} supply input to all inputs/outputs |
| Power consumption | 5 VA (basic instrument), 7 VA max. with signal output |

General Specifications

| | |
|-------------------------------------|---|
| Operating temperature | 0 to 50°C (32 to 122°F) (R.H. < 90% non-condensing) |
| Storage temperature | -10 to 60°C (14 to 140°F) (R.H. < 90% non-condensing) |
| Insulation reference voltage | 300 V _{rms} to ground |
| Dielectric strength | 4000 V _{rms} for 1 minute |
| Noise rejection | NMRR 40 dB, 40 to 60 Hz. CMRR 100 dB, 40 to 60 Hz. |
| EMC | IEC 60801-2, IEC 60801-3, IEC 60801-4 (level 3), EN 50 081-1, EN 50 082-1 |
| Safety standards | EN 61 010-1, IEC 61010-1, VDE 0411 |
| Connector | Screw-type, detachable |
| Housing | Dimensions Material |
| | 1/8 DIN, 48 x 96 x 124 mm ABS, self-extinguishing: UL 94 V-0 |
| Degree of protection | IP 65 (standard) |
| Weight | Approx 520 g (Signal output and packing included) |
| Approvals | UL, CSA, CE |

Dimensions

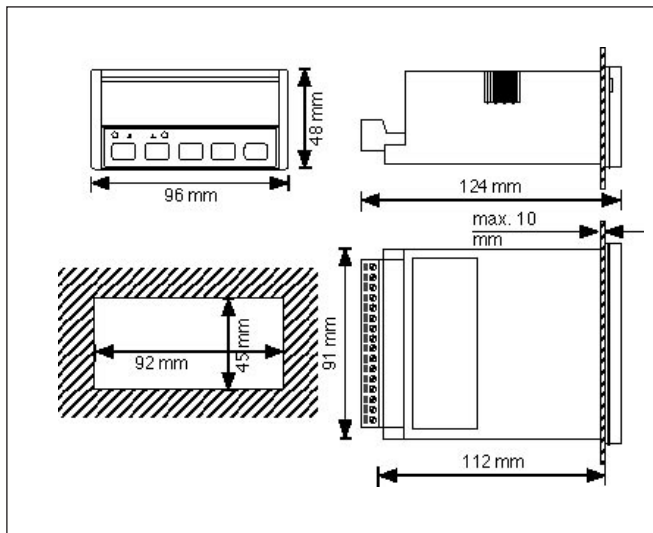

Terminal Board

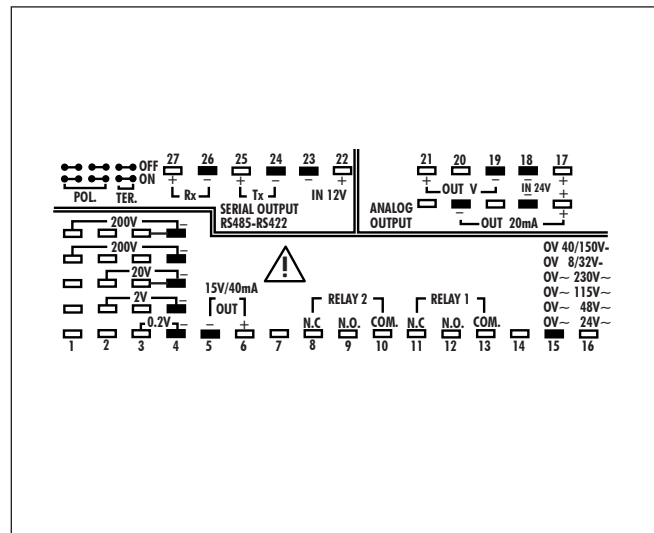

Front Panel Description

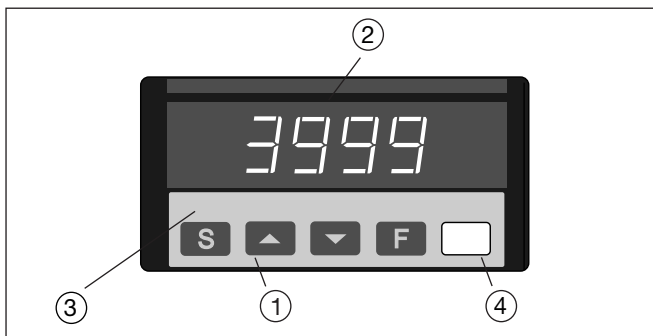

1. Key-pad

Set-up and programming procedures are easily controlled by the 4 pushbuttons.

“S”

- Selection key to select programming function (instrument configuration) or measurement and alarm detection.

“▲” and “▼”

- Up and down keys for increasing or decreasing programming values.
- Selecting programming functions and instrument configuration together with the “S” key.

“F”

- Special function key for interaction between the two set-points and for alarm latch reset.

2. Display

3 3/4-digit (maximum read-out 3999).

Alphanumeric indication by means of 7-segment display for:

- Displaying of the measured value, over-range and programming indications.
- Indication of programming parameters.

3. LED

- “1” and “2” LED indicators for alarm conditions

4. Engineering unit

Screen for interchangeable unit label. The symbols in the shaded areas are those available on the set of engineering unit labels supplied with the MDI (engineering unit label to be inserted by customer).

| | | | | | |
|---------|-----------|--------------------------|--------------------------|--------------------------|---------------------|
| | W = 08 | MΩ = 16 | % = 24 | mm HG = 32 | cm = 40 |
| mV = 01 | kW = 09 | Hz = 17 | mbar = 25 | l/min = 33 | m = 41 |
| V = 02 | MW = 10 | kHz = 18 | bar = 26 | l/h = 34 | kg = 42 |
| kV = 03 | var = 11 | RPM = 19 | psi = 27 | kg/min = 35 | ppm = 43 |
| μA = 04 | kvar = 12 | m/s = 20 | ata = 28 | ton/h = 36 | kA = 44 |
| mA = 05 | Mvar = 13 | m ³ /min = 21 | ate = 29 | m ³ /min = 37 | cos φ = 45 |
| A = 06 | Ω = 14 | °C = 22 | kg/cm ² = 30 | m ³ /h = 38 | m ² = 46 |
| mW = 07 | kΩ = 15 | °F = 23 | mm H ₂ O = 31 | mm = 39 | μs = 47 |