

# Panel Meters and Controllers

## Controller for Temperature Measurements

### Type MDI 40 CF

CARLO GAVAZZI



- 3 3/4-dgt multi-range  $\mu$ P-based controller
- Temperature measurements in  $^{\circ}\text{C}$  or  $^{\circ}\text{F}$  by means of thermoresistance or thermocouple probes and resistance measurement
- All software functions selectable by key-pad
- Peak/valley function
- Password protection of programming parameters
- 2 independent alarm setpoints
- Alarm for over-range, up-alarm, down-alarm, down alarm with disabling at power-on, up/down-alarm with latch
- Degree of protection: IP 65
- Optional analogue output (20 mA/10 VDC)
- Optional serial RS 485 output
- MODBUS, JBUS protocol.

### Product Description

3 3/4-dgt multi-range  $\mu$ P-based controller for temperature measurements in  $^{\circ}\text{C}$  or  $^{\circ}\text{F}$ . Input from thermoresistance or thermocouple and resistance. Scaling and setpoints are fully programmable by

user-friendly key-pad. The MDI 40 CF includes peak/valley function and password protection. The housing is easy to mount and ensures a degree of protection of IP 65.

### Ordering Key **MDI40CFX D2A XXIX**

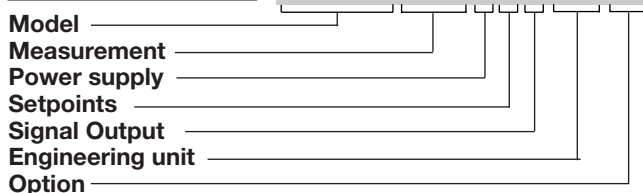

### Type Selection

Measurements	Power supply	Signal output	Options
<b>CFX:</b> Std., input: Pt100 Ni100 200 $\Omega$ TC: J, L, K, T, E <b>CFP:</b> Std., input: Pt1000 2000 $\Omega$ TC: J, L, K, T, E	<b>A:</b> 24 VAC, -15% +10%, 50/60 Hz <sup>1)</sup> <b>B:</b> 48 VAC, -15% +10%, 50/60 Hz <sup>1)</sup> <b>C:</b> 115 VAC, -15% +10%, 50/60 Hz <sup>1)</sup> <b>D:</b> 230 VAC, -15% +10%, 50/60 Hz (standard) <b>E:</b> 120 VAC, -15% +10%, 50/60 Hz <sup>1)</sup> <b>F:</b> 240 VAC, -15% +10%, 50/60 Hz <sup>1)</sup> <b>3:</b> 9 to 32 VDC with galvanic insulation <sup>1)</sup> <b>6:</b> 40 to 150 VDC with galvanic insulation <sup>1)</sup>	<b>X:</b> None <b>A:</b> Analogue: from 0 to 20 mA/from 0 to 10 V <b>R:</b> Serial: RS 485 unidirectional <b>S:</b> Serial: RS 485 bidirectional <b>W:</b> Analogue (A) + serial (R) <b>Y:</b> Analogue (A) + serial (S)	<b>IX:</b> Degree of protection IP 65 (standard) <b>01:</b> Interactive setpoints + IP 65 <sup>1)</sup> <b>XT:</b> Tropicalization + IP 65 <sup>1)</sup>

<sup>1)</sup> On request

### Input Specifications

<b>Accuracy</b> RTD (@ 25 $^{\circ}\text{C}$ $\pm$ 5 $^{\circ}\text{C}$ , R.H. $\leq$ 60%) Pt100/Pt1000 Ni100 TC (@ 25 $^{\circ}\text{C}$ $\pm$ 5 $^{\circ}\text{C}$ , R.H. $\leq$ 60%) From -50 $^{\circ}\text{C}$ to the limit of input range From -200 $^{\circ}\text{C}$ to -5 $^{\circ}\text{C}$ of the input range Resistance (@ 25 $^{\circ}\text{C}$ $\pm$ 5 $^{\circ}\text{C}$ )	$\pm$ 0.15% f.s., $\pm$ 2 dgt $\pm$ 0.5% f.s., $\pm$ 1dgt  $\pm$ 0.2% f.s., $\pm$ 2 dgt  $\pm$ 1% f.s., $\pm$ 2 dgt $\pm$ 0.1% f.s., $\pm$ 2 dgt	<b>Temperature drift</b> RTD TC Resistance <b>Sampling rate</b> <b>Display</b> <b>Max. and min. indication</b> RTD/TC Resistance	$\pm$ 200 ppm/ $^{\circ}\text{C}$ , thermoresistance $\pm$ 200 ppm/ $^{\circ}\text{C}$ , thermocouple $\pm$ 200 ppm/ $^{\circ}\text{C}$ 2 times/s, dual slope 16 bits A/D converter 7-segment LED, h 14.2 mm Depending on range and type of the temperature probe Max. 200 $\Omega$ (std), 2000 $\Omega$ (on request) min. 0
--	--	--	--

## Input Specifications (cont.)

<b>Compensation</b>		<b>Input TC ranges</b>	
RTD	For 3-wire connections, line resistance up to 10 $\Omega$	Probe: TC-J	-50 to 760°C (-58 to 1400°F)
TC	Cold junction, within the temperature range	Probe: TC-L	-50 to 760°C (-58 to 1400°F)
		Probe: TC-K	-200 to 1260°C (-328 to 2300°F)
		Probe: TC-T	-200 to 400°C (-328 to 752°F)
		Probe: TC-E	-200 to 1260°C (-328 to 2300°F)
<b>Input RTD ranges</b>		<b>Key-pad</b>	
Probe: Pt100	-200 to 850°C (-328 to 1562°F)	4 keys:	
Probe: Ni100	-60 to 180°C (-76 to 356°F)	“S” for menu selection;	
Probe: Pt1000	-200 to 850°C (-328 to 1562°F) on request	“UP” and “DOWN” for value programming/function selection;	
		“F” for special functions	
<b>Input <math>\Omega</math> range:</b>			
	0 $\Omega$ to 200 $\Omega$		
	0 $\Omega$ to 2000 $\Omega$ , on request		

## Output Specifications

<b>Alarms</b>		<b>Analogue output (cont.)</b>	
Number of setpoints	2 independent (standard)	Accuracy	$\pm 0.3\%$ f.s. (@ 25°C)
Alarm types	Over-range, up alarm, down alarm, down alarm with disabling at power-on, up alarm with latch, down alarm with latch.	Response time	$\leq 500$ ms
Special function	Interaction of the two setpoints, except for Ni100/TC-E measurement (on request).	Temperature drift	$\pm 200$ ppm/°C
Setpoint adjustment	0 to 100% of the displayed range.	Load: 20 mA output	$\leq 500$ $\Omega$
Limits of setpoint adjustment	Programmable minimum and maximum values.	10 V output	$\geq 10$ k $\Omega$
Hysteresis	0 to 100% of the displayed range.	Insulation	By means of optocouplers, 500 V <sub>ms</sub> outputs to measuring inputs
On-time delay	0 to 255 s		4000 V <sub>ms</sub> output to supply input
Off-time delay	0 to 255 s	<b>Serial output</b>	
Relay status	Normally energized/de-energized	Type	RS485
Output type		Multidrop	Unidirectional, (STD) bidirectional (on request)
Contact	2 x SPDT	Connections	2 or 4 wires, max. distance 1200m, termination and/or line biasing directly on the instrument
Rating	5 A, 250 VAC/VDC, 40 W/1200 VA, 130.000 cycles	Addresses/protocol	255, selectable by key-pad/MODBUS, JBUS
Min. response time	$\leq 400$ ms, filter excluded, setpoint on-time delay: “0”	Data (unidirectional)	
Insulation	2000 V <sub>ms</sub> output to measuring inputs, output to excitation output.	Dynamic (reading only)	Measurement, data hold of minimum value, data hold of maximum value, alarm status
		Static (reading only)	All programming data
<b>Excitation output</b>		Data (bidirectional, on request)	
Voltage	15 VDC non-stabilized/40 mA max. (only in case of W or Y option)	Dynamic (reading only)	Measurement, data hold of minimum value, data hold of maximum value, alarm status
Insulation	100 V <sub>ms</sub> output to measuring input	Static (reading/writing)	All programming data, min./max. data hold reset, reset of alarm setpoints with latch
	4000 V <sub>ms</sub> output to AC supply input		1-start bit, 8-data bit, no parity, 1 stop bit
	500 V <sub>ms</sub> output to DC supply input	Data format	1200, 2400, 4800 and 9600 selectable bauds
<b>Analogue output</b>		Baud-rate	By means of optocouplers, 500 V <sub>ms</sub> output to measuring inputs
Range	0 to 20 mADC, 0 to 10 VDC	Insulation	4000 V <sub>ms</sub> output to supply input
Scaling factor	Programmable within the whole range of the signal output; it allows the management of all values from 0 to 20 mA / from 0 to 10 V		

## Software Functions

<b>Peak and valley values</b>	Automatic storage (RAM only) of the min. and max. value measured from the last reset	<b>Scaling factor (cont.)</b> Decimal point position	Programmable within the displaying range
		Displayed scale	Programmable within the whole displaying range
<b>Password</b>	Numeric code of max. 3 digits; 3 protection levels of the programming data	<b>Diagnostics</b>	The display flashes when the limits of the displayed range are exceeded, the data are updated up to the maximum read-out
1st level	Password "0", no protection		
2nd level	Password from 1 to 127, all data are protected	Burn-out up	Opening of the probe connection, EEE indication
3rd level	Password for 128 to 255, all data are protected except for the setpoints	TC	Opening of the probe connection, EEE indication
<b>Measurement selection</b>	Thermoresistance (RTD), resistance/thermocouple (TC)	RTD	Probe short-circuit, -EE indication
<b>Scaling factor</b>		<b>Filter</b>	
Operating mode	Electrical scale compression, compression/expansion of the displayed scale (max. 2 without filter, > 2 with filter)	Filter operating range	From 0 to 3999
	Programmable within the whole measuring range	Filtering coefficient	From 1 to 255
Electrical scale			

## Supply Specifications

<b>AC supply</b>	230 VAC, -15%+10%, 50/60 Hz (standard) 24 VAC, 48 VAC, 115 VAC, 120 VAC, 240 VAC, -15%+10%, 50/60 Hz (on request)
Insulation	4000 V <sub>rms</sub> supply input to all the other inputs/outputs
<b>DC supply</b>	9 to 32 VDC, galvanic insulation max. inrush current: ≤ 1.2 A/200 ms (on request)
	40 to 150 VDC, galvanic insulation max. inrush current: ≤ 0.6 A/200 ms (on request)
Insulation	500 V <sub>rms</sub> supply input and all inputs/outputs
<b>Power consumption</b>	5 VA (basic instrument), 7 VA max. with signal output

## General Specifications

<b>Operating temperature</b>	0° to 50°C (32° to 122°F) (R.H. < 90% non-condensing)
<b>Storage temperature</b>	-10° to 60°C (14° to 140°F) (R.H. < 90% non-condensing)
<b>Insulation reference voltage</b>	300 V <sub>ms</sub> to ground
<b>Dielectric strength</b>	4000 V <sub>ms</sub> for 1 minute
<b>Noise rejection</b>	NMRR 40 dB, 40 to 60 Hz CMRR 100 dB, 40 to 60 Hz
<b>EMC</b>	IEC 60801-2, IEC 60801-3, IEC 60801-4 (level 3), EN 50 081-1, EN 50 082-1
<b>Safety standards</b>	EN 61 010-1, IEC 61010-1, VDE 0411
<b>Connector</b>	Screw-type, detachable
<b>Housing</b>	Dimensions Material
	1/8 DIN, 48 x 96 x 124 mm ABS, self-extinguishing: UL 94 V-0
<b>Degree of protection</b>	IP 65 (standard)
<b>Weight</b>	Approx 520 g (signal output and packing included)
<b>Approvals</b>	UL, CSA, CE

## Dimensions

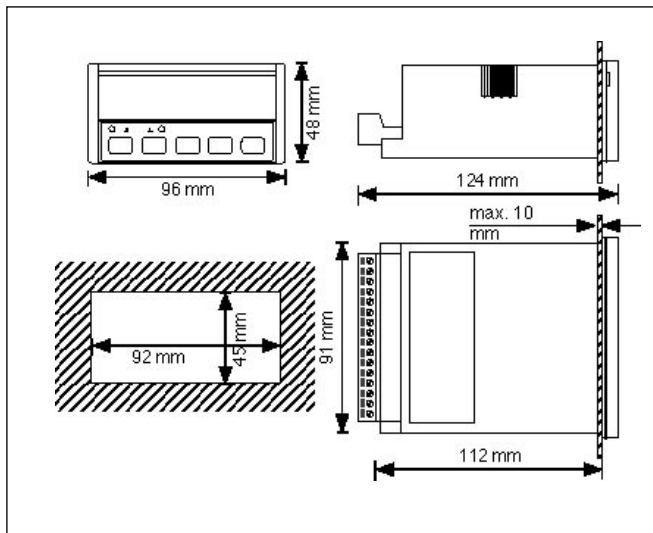

## Terminal Board

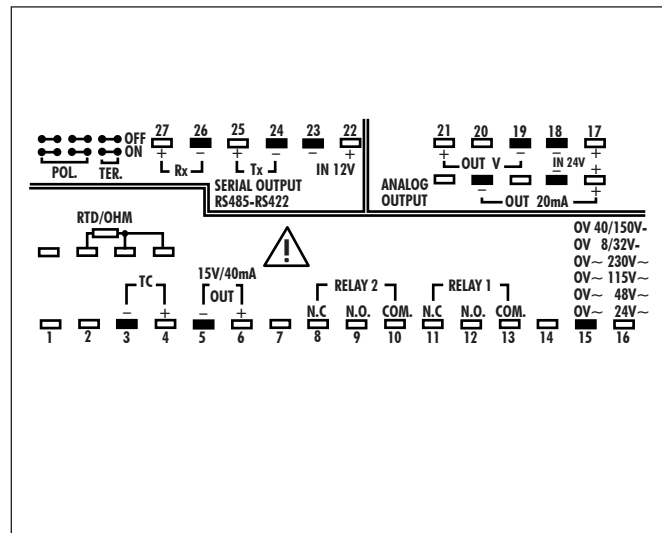

## Front Panel Description

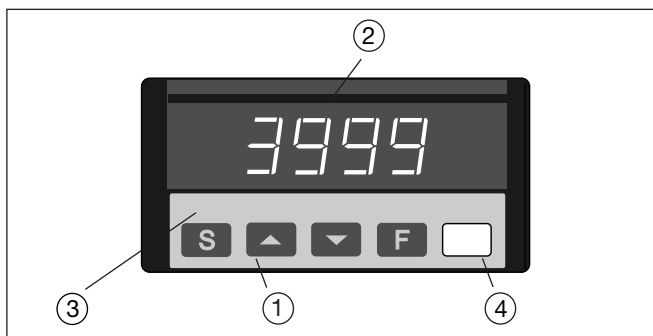

### 1. Key-pad

Set-up and programming procedures are easily controlled by the 4 pushbuttons.

“S”

- Selection key to select programming function (instrument configuration) or measurement and alarm detection.

” ▲ ” and ” ▼ ”

- Up and down keys for increasing or decreasing programming values.
- Selecting programming functions and instrument configuration together with the ”S” key.

“F”

- Special function key for interaction between the two set-points and for alarm latch reset.

### 2. Display

3 3/4-digit (maximum read-out 3999).

Alphanumeric indication by means of 7-segment display for:

- Displaying of the measured value, over-range, burn-out and programming indications.
- Indication of programming parameters.

### 3. LED

- ”1” and ”2” LED indicators for alarm conditions

### 4. Engineering unit

Screen for interchangeable unit label. The symbols in the shaded areas are those available on the set of engineering unit labels supplied with the MDI (engineering unit label to be inserted by customer).

	W = 08	MΩ = 16	% = 24	mm HG = 32	cm = 40
mV = 01	kW = 09	Hz = 17	mbar = 25	l/min = 33	m = 41
V = 02	MW = 10	kHz = 18	bar = 26	l/h = 34	kg = 42
kV = 03	var = 11	RPM = 19	psi = 27	kg/min = 35	ppm = 43
μA = 04	kvar = 12	m/s = 20	ata = 28	ton/h = 36	kA = 44
mA = 05	Mvar = 13	m/min = 21	ata = 29	m <sup>3</sup> /min = 37	cos φ = 45
A = 06	Ω = 14	°C = 22	kg/cm <sup>2</sup> = 30	m <sup>3</sup> /h = 38	m <sup>3</sup> = 46
mW = 07	kΩ = 15	°F = 23	mm H <sub>2</sub> O = 31	mm = 39	μs = 47