



## Plastic Bodied Heavy Duty Telephone



- Full keypad, full keypad with memory, CB and 1, 3 and 6 button programmable autodialler telephones.
- Robust and weather resistant to IP65.
- Dual purpose design for wall or desk mounting, simple installation.
- Industry standard robust handset c/w armoured cord.
- DTMF/LD and Earth/Timed Break Recall.
- Large tactile buttons, easy to see and operate.
- CE / BABT and ACA Compliant (SMART option tested to iCTR 37 / CTR 38).
- Optional variant available with SMART (Self Monitoring And Reporting).

This industrial family of telephones are tough, weather resistant units built to withstand operator abuse and environmental extremes.

The body of the phone is made from glass filled polyester to alleviate rust and corrosion. Coupled with its ergonomically designed handset and 1 metre long armoured cord, it is aesthetically pleasing to the eye. The elimination of moving parts brings new levels of reliability to industrial and weather resistant telephones.

Internal switching provides for LD/MF and ELR/TBR operation to enable connection to most PABX, PBX and PAX systems. Time out is standard. Should the handset be left off-hook, the phone will automatically revert to normal on-hook state after a period of 6-8 minutes. Also standard fitting is an inductive coupler for the hard of hearing.

Keypad options range from full 18 key to zero for the CB version. Included in the 18 button version, are 3 direct dial buttons for fast one touch dialling of pre-stored numbers or accessing low cost call facilities.

The 15 and 18 keypad versions include:

- S** - 'Microphone mute' or 'Silence',
- R** - 'Recall',
- LR** - 'Last number redial'.

### New South Wales:

Tel: (02) 8851 5000  
Fax: (02) 9899 2490  
[austdac.nsw@austdac.com.au](mailto:austdac.nsw@austdac.com.au)

[www.austdac.com.au](http://www.austdac.com.au)

Brochure No:

03-179-35-xx04-05-e\_plastic\_bodied\_heavy\_duty\_phone.pdf

### Queensland:

Tel: (07) 4955 2777  
Fax: (07) 4955 2922  
[austdac.qld@austdac.com.au](mailto:austdac.qld@austdac.com.au)

Industrial  
Telephones

AUSTDAC PTY. LTD.

A.B.N. 31 002 654 695



## Plastic Bodied Heavy Duty Telephone

### *Plastic Bodied Heavy Duty Telephone Models*

#### ***Keypad Diallers:***

These models are configurable to be fully compatible with most PABX's or PTT networks. Loop disconnect (LD) and Tone dialling (DTMF) systems are internally selectable, as are Time Break Recall (TBR) and Earth Loop Recall (ELR).

#### ***1, 3 & 6 button Autodiallers***

These models are programmable via an internal keypad. A microphone muting facility guards against unauthorised calls made with a remote MF tone pad. To make a call, simply lift the handset and press a single button. The pre-programme number (up to 24 digits) will then dial automatically.



#### ***CB Telephone:***

This can be used to initiate a PABX 'hotline' or lift handset and wait for reply, where the PABX does the call routing/dialling.



#### ***SMART Option:***

Self Monitoring And Reporting Telephone optional variants available, please call.

#### ***New South Wales:***

Tel: (02) 8851 5000

Fax: (02) 9899 2490

[austdac.nsw@austdac.com.au](mailto:austdac.nsw@austdac.com.au)

[www.austdac.com.au](http://www.austdac.com.au)

Brochure No:

03-179-35-xx04-05-e\_plastic\_bodied\_heavy\_duty\_phone.pdf

#### ***Queensland:***

Tel: (07) 4955 2777

Fax: (07) 4955 2922

[austdac.qld@austdac.com.au](mailto:austdac.qld@austdac.com.au)

Industrial  
Telephones

AUSTDAC PTY. LTD.

A.B.N. 31 002 654 695



## Plastic Bodied Heavy Duty Telephone

### *Technical Specifications*

**Speech:**

Transmission to BS6317 : 1982,  
Part 13, Class A.

**Dialling Data:**

LD to : BS 6305 : 1982, Part 4.4.2.  
Impulse rate : 10 ips  
Mark/space ratio : 2:1  
MF: BS6305 : 1982, Part 4.4.3  
MF impedance : Class A  
MF transient voltage : Class A  
Dialling tones meet international  
standard requirements.

**Ringing Tone:**

Shrill warble tone 80 dBA @ 1 metre typical.

**Hookswitch:**

Electronic with no mechanical moving parts.

**Integral programming keypad:**

(Autodialling models ONLY).

**Time Out:**

Enforces a fixed call maximum time limit to  
6-8 minutes from lifting of the handset.  
This facility can also be disabled.

**Recall Button:**

Internally switchable from Earth Loop Recall,  
Timed Break Recall.or Hook Flash.

**Power Supply:**

Drawn from telephone line.

**Operating Temperature:**

-20° C to +55° C

**Relative Humidity:**

Up to 95% (non-condensing).

**Degree of protection:**

IP65.

**Casing Material:**

Glass filled polyester.  
Colours yellow, grey or  
special order.

**Handset Material:**

Cycloy (2850) with stainless  
steel spiral cord.

**Keypad:**

Weathersealed tactile  
digital keypad.

**Weight:**

2.5 kg approx.

Industrial  
Telephones

AUSTDAC PTY. LTD.

A.B.N. 31 002 654 695

**New South Wales:**

Tel: (02) 8851 5000  
Fax: (02) 9899 2490  
[austdac.nsw@austdac.com.au](mailto:austdac.nsw@austdac.com.au)

[www.austdac.com.au](http://www.austdac.com.au)

Brochure No:

03-179-35-xx04-05-e\_plastic\_bodied\_heavy\_duty\_phone.pdf

**Queensland:**

Tel: (07) 4955 2777  
Fax: (07) 4955 2922  
[austdac.qld@austdac.com.au](mailto:austdac.qld@austdac.com.au)

# Plastic Bodied Heavy Duty Telephone

## Dimensions

H-292mm x W-190mm x D-140mm.  
Fixing Centres (see below)

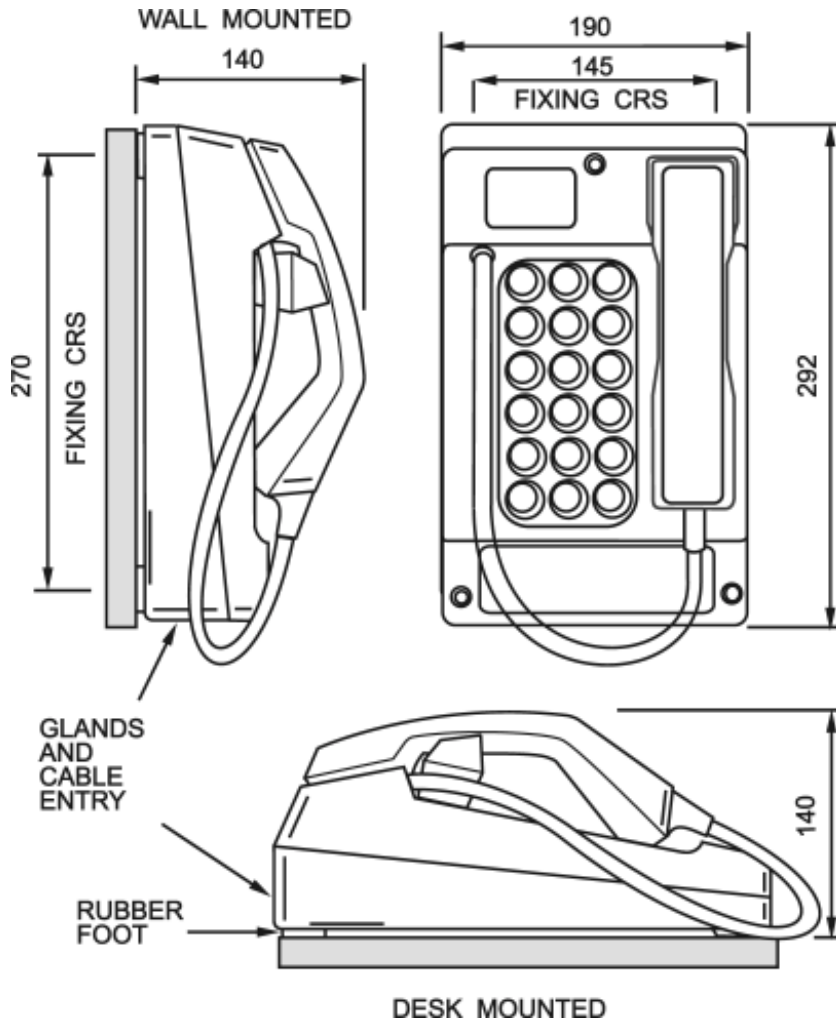

## Approvals

ACA Compliant.

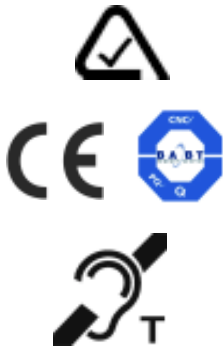

GAI-Tronics has been assessed and approved by BAPT as a listed production facility for simple and feature telephones.

This mark indicates compliance for inductively coupling to Hearing Aids having a 'T' switch position in accordance with the relevant OfTel Code of Practice.

Tested to ETS 300-381 and in accordance with CCITT P37.

### New South Wales:

Tel: (02) 8851 5000

Fax: (02) 9899 2490

[austdac.nsw@austdac.com.au](mailto:austdac.nsw@austdac.com.au)

[www.austdac.com.au](http://www.austdac.com.au)

Brochure No:

03-179-35-xx04-05-e\_plastic\_bodied\_heavy\_duty\_phone.pdf

### Queensland:

Tel: (07) 4955 2777

Fax: (07) 4955 2922

[austdac.qld@austdac.com.au](mailto:austdac.qld@austdac.com.au)